

ONSITE SYSTEMS MANUAL

May 2016



San Mateo County Environmental Health Division

2000 Alameda de las Pulgas, Suite 100
San Mateo, CA 94403
650-372-6200
www.smchealth.org/landuse



San Mateo County Onsite Systems Manual

OVERVIEW

This *Onsite Systems Manual* (also “Onsite Manual”, “Manual” or “OSM”) provides the policy, procedural and technical details for implementation of the provisions of the San Mateo County Onsite Wastewater Treatment Systems (OWTS) Ordinance, codified in Chapter 4.84 of Title 4 – Sanitation and Health of the San Mateo County Ordinance Code. Section 4.84.020 provides further that:

- The *Onsite Systems Manual* shall be developed and maintained by Environmental Health, and shall provide a reasonable process for seeking input from the affected public and OWTS practitioners, such as OWTS designers and installers, regarding its development and any changes made to it.
- The *Onsite Systems Manual* and any amendments to it shall be subject to approval by Environmental Health and the San Francisco Bay and Central Coast Regional Water Quality Control Boards (RWQCB) in accordance with applicable State requirements and policies for onsite wastewater treatment.

This Manual replaces the former “Performance Standard”, and incorporates new and updated information regarding design details and guidelines related to both conventional and alternative systems, operation and monitoring requirements and related procedural matters. It is intended to provide technical guidance for homeowners, designers, and installers of onsite wastewater treatment and dispersal systems.

It is expected that Environmental Health will periodically review and make amendments to the various procedures and technical information contained in this Onsite Systems Manual, typically on an annual or biannual basis. The amendments may include recommended changes originating from Environmental Health staff, RWQCB staff, other departments or agencies, contactors and consultants working in the OWTS industry, or other affected groups or individuals. Any substantive changes in requirements, such as changes in design criteria or addition of alternative design options, are expected to involve review and approval by the RWQCB as an update to the County Local Agency Management Program (LAMP).



The Onsite System Manual is divided into six main sections as follows:

Section 1: Policies and Administrative Procedures

Section 2: Site Investigation Requirements and Procedures

Section 3: Design and Construction Requirements for Conventional OWTS

Section 4: Alternative OWTS Requirements

Section 5: OWTS Performance, Monitoring and Evaluation

Section 6: Advanced Protection Management Program

GLOSSARY OF TERMS

Unless defined otherwise in this Manual, the terms used in this Manual have the same definition as in San Mateo County Ordinance 4.84 - Onsite Wastewater Treatment Systems.

“**Alternative OWTS**” is a type of OWTS that utilizes either a method of wastewater treatment other than a conventional Septic Tank for the purpose of producing a higher quality wastewater effluent and/or a method of wastewater dispersal other than a gravity-fed trench Dispersal System for effluent dispersal.

“**Cesspool**” means an excavation in the ground receiving domestic wastewater, designed to retain the organic matter and solids, while allowing the liquids to seep into the soil. Cesspools differ from seepage pits because cesspool systems do not have septic tanks and are not authorized under the Water Quality Control Policy for Siting, Design, Operation and Maintenance of Onsite Wastewater Treatment Systems, adopted by the State Water Resources Control Board on June 19, 2012, which became effective May 13, 2013 (SWRCB OWTS Policy). The term cesspool does not include pit-privies and out-houses which are not regulated under the SWRCB OWTS Policy. (From SWRCB OWTS Policy)

“**Conventional OWTS**” means a type of OWTS consisting of a Septic Tank for primary treatment of sewage followed by gravity flow to a Dispersal System of drainfield trenches for subsurface dispersal of effluent into the soil.



“Cut or Embankment” means any area of land surface having a distinctly greater slope than the adjacent natural ground surface, greater than 36 inches in vertical height, and any part of which is lower in elevation than the ground surface at the nearest point of the OWTS. Cuts supported by retaining walls or similar structures shall be included in this definition, as shall steep natural ground surfaces where a sharp break in the ground slope is discernible.

“Dispersal System” means a series of trenches, beds, subsurface drip lines, or other approved method for subsurface infiltration and adsorption of wastewater effluent, including all component parts, such as piping, valves, filter material, chambers, dosing pumps, siphons and/or other appurtenances.

“Domestic Wastewater” means wastewater with a measured strength less than high-strength wastewater and is the type of wastewater normally discharged from, or similar to, that discharged from plumbing fixtures, appliances and other household devices including, but not limited to, toilets, bathtubs, showers, laundry facilities, dishwashing facilities, and garbage disposals. Domestic wastewater may include wastewater from commercial buildings such as office buildings, retail stores, and some restaurants, or from industrial facilities where the domestic wastewater is segregated from the industrial wastewater. Domestic wastewater may include incidental RV holding tank dumping but does not include wastewater consisting of a significant portion of RV holding tank wastewater such as at RV dump stations. Domestic wastewater does not include wastewater from industrial processes. (From SWRCB OWTS Policy)

“Drainage Swale” means any course of concentrated drainage water that has formed over time by either natural or man-made forces and where the flow of water is either at or near ground surface with no significant subsurface flow component. Also included in this definition are facilities used for the treatment and/or dispersal of roof runoff or other site drainage, such as vegetated swales and infiltration/percolation trenches or basins.

“Environmental Health” means the Director of Environmental Health Division or his/her designee.

“Groundwater” means water below the land surface that is at or above atmospheric pressure. (From SWRCB OWTS Policy)

“Holding Tank” means a watertight receptacle used to collect and store wastewater prior to it being removed from a property by means of vacuum pumping and hauling or another approved method.

“Impaired Water Body” means those surface water bodies or segments thereof that are



identified on a list approved first by the State Water Board and then approved by US EPA pursuant to Section 303(d) of the federal Clean Water Act. (From SWRCB OWTS Policy)

“Onsite Wastewater Treatment System (OWTS)” means individual disposal system, community collection and disposal systems, and alternative collection and disposal systems that use subsurface disposal. The short form of the term may be singular or plural. OWTS do not include “graywater” systems pursuant to Health and Safety Code Section 17922.12. (From SWRCB OWTS Policy)

“Operating Permit” means the administrative document issued by Environmental Health authorizing the initial and/or continued use of an alternative OWTS in conformance with the provisions of the OWTS Ordinance and this manual, intended to aid in verification of the adequacy of alternative OWTS performance, and that may contain both general and specific conditions of use. An Operating Permit may also be issued for circumstances other than alternative OWTS, such as in connection with Holding Tank exemptions, Portable Toilet installations, or where, in the opinion of Environmental Health, the type, size, location or other aspects of a particular OWTS installation warrant the additional level of oversight provided by an Operating Permit.

“OWTS Failure” means the ineffective treatment and/or dispersal of waste resulting in the surfacing of raw, or inadequately treated sewage effluent, or the degradation of surface or groundwater quality and/or such as it creates a potential public health hazard. For a Dispersal System, signs of OWTS Failure may include surfacing wastewater effluent from the dispersal field or wastewater backed up into plumbing fixtures, including a Septic Tank, because the Dispersal System is not able to percolate the design flow of wastewater associated with the structures served. For a Septic Tank, signs of OWTS Failure may include compartment baffle buckling or failure or tank structural integrity failure such that either wastewater is exfiltrating or groundwater is infiltrating.

“Percolation Testing” is a method of evaluating water absorption of the soil. The test is conducted with clean water and test results are used in the design and sizing of the Dispersal System.

“Portable Toilet” means an enclosed unit intended for temporary use at a given location. Portable Toilets may also be referred to as chemical toilets in this manual, the OWTS Ordinance or in other County ordinances or California statute or regulation.

“Pressure-dosing Distribution” means a method of wastewater dispersal used to achieve equal distribution of wastewater within a dispersal field by employing a pump or automatic dosing siphon and distribution piping with small diameter holes or perforations spaced uniformly along its length.



“Qualified OWTS Design Professional” means an individual licensed or certified by a State of California agency to design OWTS and practice as a professional as allowed under their license or registration. Individuals certifying OWTS designs must be a State of California Registered Environmental Health Specialist, Professional Geologist, or Professional Civil Engineer.

“Replacement OWTS” means an OWTS that has its treatment capacity expanded, or its dispersal system replaced or added onto, after the effective date of the SWRCB OWTS Policy. (From SWRCB OWTS Policy)

“Seepage Pit” means a drilled or dug excavation, three to six feet in diameter, either lined or gravel filled, that receives the effluent discharge from a septic tank or other OWTS treatment unit for dispersal. (From SWRCB OWTS Policy)

“Septic Tank” means a watertight, covered receptacle designed for primary treatment of wastewater and constructed to:

1. Receive wastewater discharged from a building;
2. Separate settleable and floating solids from the liquid;
3. Digest organic matter by anaerobic bacterial action;
4. Store digested solids; and
5. Clarify wastewater for further treatment with final subsurface discharge.

(From SWRCB OWTS Policy)

“Site Evaluation” means an assessment of the characteristics of the site sufficient to determine its suitability for an OWTS to meet the requirements of the SWRCB OWTS Policy. (From SWRCB OWTS Policy)

“Soil” means the naturally occurring body of porous mineral and organic materials on the land surface, which is composed of unconsolidated materials, including sand-sized, silt-sized, and clay-sized particles mixed with varying amounts of larger fragments and organic material. The various combinations of particles differentiate specific soil textures identified in the soil textural triangle developed by the United States Department of Agriculture (USDA) as found in Soil Survey Staff, USDA; *Soil Survey Manual, Handbook 18*, U.S. Government Printing Office, Washington, DC, 1993, p. 138. For the purposes of the SWRCB OWTS Policy, soil shall contain earthen material of particles smaller than 0.08 inches (2mm) in size. (From SWRCB OWTS Policy)

“Supplemental Treatment” means any OWTS or component of an OWTS, except a septic tank or dosing tank, that performs additional wastewater treatment so that the effluent meets a predetermined performance requirement prior to discharge of effluent



into the dispersal field. (From SWRCB OWTS Policy)

“Total Maximum Daily Load (TMDL)” Section 303(d)(1) of the Clean Water Act requires each State to establish a TMDL for each impaired water body to address the pollutant(s) causing the impairment. In California, TMDLs are usually adopted as Basin Plan amendments and contain implementation plans detailing how water quality standards will be attained. (From SWRCB OWTS Policy)

“Unstable Land Mass” means land prone to subsidence, erosion, or mass land movement as indicated by historical landslide events, published maps or reports, or evidence of characteristics such as surface rupture, scarps, creep or other irregularities in ground slope conditions.

“Waste Discharge Requirement (WDR)” means an operation and discharge permit issued for the discharge of waste pursuant to Section 13260 of the California Water Code. (From SWRCB OWTS Policy)

“Watercourse” means a definite channel with bed and banks within which water flows either perennially, ephemerally or intermittently, including overflow channels contiguous to the main channel. A Watercourse may be either a natural or man-made channel. For the purpose of this Chapter, Watercourse also includes water bodies such as ponds, lakes, marshes, seasonal wetlands and tidal waters.



SECTION 1

POLICIES AND ADMINISTRATIVE PROCEDURES

CONTENTS

- A. INTRODUCTION
 - B. FEES
 - C. CERTIFICATION OF SOIL PERCOLATION TESTERS
 - D. CERTIFICATION OF OWTS INSTALLERS
 - E. REQUIREMENTS FOR SEPTAGE PUMPING AND CLEANING COMPANIES AND TRUCKS
 - F. ENVIRONMENTAL HEALTH REVIEW FOR PLANNING OR BUILDING PERMITS
 - G. INSTALLATION PERMIT REQUIREMENTS
 - H. OWTS SUBJECT TO CRWQCB WASTE DISCHARGE REQUIREMENTS
 - I. OVER 50% REMODEL OR ADDITION OF A BEDROOM
 - J. UNDER 50% REMODEL WITH NO BEDROOM ADDITION
 - K. SECOND DWELLING UNITS
 - L. REPAIR OF EXISTING OWTS
 - M. DESTRUCTION OF SEPTIC TANKS AND LEACH TRENCHES
 - N. SUBDIVISIONS AND LOT LINE ADJUSTMENTS
 - O. PROPERTIES NEAR A SANITARY SEWER SYSTEM
 - P. ALTERNATIVE SYSTEMS
 - Q. OPERATING PERMITS
 - R. EXEMPTIONS (VARIANCE)
 - S. AMENDMENTS TO THIS MANUAL
- FORMS AND FIGURES



SECTION 1

POLICIES AND ADMINISTRATIVE PROCEDURES

A. INTRODUCTION

Section 1 of the Onsite Systems Manual provides an overview and clarification of various onsite wastewater treatment systems (OWTS) and other wastewater related policies and administrative procedures pertaining to:

- OWTS and other wastewater related permits and fees;
- Certifications of soil percolation testers, OWTS installers and septage pumping companies;
- Development and OWTS requirements for site approval for building projects, secondary dwellings, remodeling projects, and subdivisions;
- Requirements for properties located near sanitary sewer systems;
- Repair or destruction of existing septic systems;
- Provisions and permitting requirements for alternative treatment and dispersal systems;
- Provisions and permitting requirements for septic holding tanks and portable toilets; and
- Amendments to this Onsite Systems Manual.

B. FEES

Fees, as prescribed by resolution of the Board of Supervisors of the County of San Mateo, are payable separately to Environmental Health for services described throughout this Manual. See Environmental Health website for listing of applicable fees. Fees are non-refundable once received by Environmental Health.

Note that a fee waiver may be considered for OWTS work consistent with Board of Supervisors resolutions (i.e., farm labor housing units).

C. CERTIFICATION OF SOIL PERCOLATION TESTERS

Soil percolation testing is a method of evaluating water absorption of the soil. The test is conducted with clean water and test results are used in the design and sizing of the dispersal system. No person shall perform soil percolation testing or submit testing results unless they possess a current certification issued by Environmental Health as prescribed below.



1. Environmental Health shall certify any applicant who demonstrates competence to test and make reports on soil percolation testing in compliance with the requirements of San Mateo County Ordinance 4.84 and as prescribed in below, and who has paid an annual certification fee as set forth in San Mateo County Ordinance Section 5.64.070. Applicants shall demonstrate such competence by one of the following.
 - a. Presenting a current valid registration or certification as a State of California Registered Environmental Health Specialist, Professional Geologist, or Professional Civil Engineer.
 - b. Undertaking and passing an examination administered by Environmental Health.
2. Any such certificate holder may be required to undergo re-examination, additional training, other demonstration of competency or any combination thereof, as may be deemed necessary by Environmental Health.
3. Soil percolation tester certification may be renewed annually by payment of the annual certification fee. Payment must be made before expiration of certification. If there is any lapse in certification, Environmental Health may require the tester to undergo re-examination, additional training, or other demonstration of competency, or any combination thereof prior to re-certification.

D. CERTIFICATION OF OWTS INSTALLERS

A Certified Installer is any individual, organization, partnership, business, association, or corporation holding a current authorization to install or repair OWTS in San Mateo County as described below. No person shall install, construct, add to, alter, or replace an OWTS in San Mateo County unless they possess a current certification issued by Environmental Health as prescribed below. This certification shall be in addition to any license required by State law to install the OWTS.

1. Environmental Health shall certify any applicant who demonstrates competence to install, construct, add to, alter, or replace an OWTS in compliance with the requirements of San Mateo County Ordinance 4.84 and as prescribed below, and who has paid an annual certification fee as set forth in San Mateo County Ordinance Section 5.64.070. Applicants shall demonstrate such competence by one of the following.
 - a. Presenting a current and valid State of California contractor license (“A” – General Engineering Contractor; C36 – Plumbing Contractor; or C42:



Sanitation System Contractor).

- b. In the case of a property owner personally installing or repairing their own Conventional OWTS on property they own, property owners must undertake and pass an examination administered by Environmental Health and all work must be in compliance with this Chapter and as prescribed in the Onsite Systems Manual.
2. Any such certificate holder may be required to undergo re-examination, additional training, other demonstration of competency or any combination thereof, as may be deemed necessary by Environmental Health.
 3. OWTS installer certification may be renewed annually by payment of the annual certification fee. Payment must be made before expiration of certification. If there is any lapse in certification, Environmental Health may require the installer to undergo re-examination, additional training, or other demonstration of competency, or any combination thereof prior to re-certification.

E. REQUIREMENTS FOR SEPTAGE PUMPING AND CLEANING COMPANIES AND TRUCKS

1. **Septage Pumping Company Applications.** All applications for certification of a septage pumping and cleaning company shall be completed in full and filed with Environmental Health as prescribed below. The application shall be signed by an authorized officer of the corporation or by a managing partner.
 - a. The applicant shall use a disposal site(s) approved by Environmental Health for receiving OWTS, holding tank or portable toilet septage wastes.
 - b. The applicant shall demonstrate to the satisfaction of Environmental Health, their knowledge of, and competence with, the equipment to be used as well as the sanitary principles, laws and ordinances which affect human health or public nuisances.
 - c. The applicant shall utilize sanitary equipment meeting the requirements as prescribed below.
 - d. Pumper Registration shall be valid for twelve (12) months. It shall be the responsibility of the applicant to renew this registration annually.
 - e. All certified pumpers shall be required to file a monthly statement with Environmental Health, giving the name and address of the owner or tenant of each of the premises where an OWTS, holding tank or portable toilet has



been cleaned out by said pumper, his employees or others on his behalf. This statement shall also describe the place where the cleanings have been disposed.

- f. **Septic Tank Pumping.** Whenever an OWTS is serviced for the purpose of septic tank pumping, pumping of the tank and visual inspection of the tank, pumps, visible piping and dispersal field area shall be made by the pumper, as prescribed below.
- g. A written report on form(s) provided by Environmental Health shall be completed by the registered septic tank pumper and shall be submitted to Environmental Health and the property owner no later than 30 days following septic tank pumping as prescribed below.
- h. Upon being notified of a failure condition or other uncorrected deficiency in an OWTS, Environmental Health will notify the owner in writing, by hand-delivery or first class U.S. mail, of the needed corrections required to comply with the applicable standards in this manual.
- i. Within 60 days of notice of such written notification, the property owner shall take all corrective actions necessary to comply with the applicable standards, unless otherwise approved by Environmental Health.

2. Pumper truck inspections. All pumper trucks operating within San Mateo County must be inspected and certified by Environmental Health.

- a. The pumper truck tank shall hold a volume at least equal to or exceeding the volume of the tank being pumped, be in good repair, and be constructed in a manner to facilitate cleaning.
- b. All outer contact surfaces and fittings shall be kept in a clean and sanitary condition while stored or in transit, and all premises served and equipment used shall be left in a clean and sanitary condition.
- c. All discharge valves shall be in good repair, free from leaks and fitted with water-tight caps.
- d. The pumper truck must have a spill clean-up kit on board at all times.
- e. The name of the operating firm shall be prominently displayed on the sides of any pump tank vehicle.
- f. The pumper truck must bear a valid Environmental Health ID Permit unique to each vehicle, as affixed by Environmental Health staff following inspection. The ID Permit is not transferable to any other vehicle.



3. **Septic Tank Pumping.** Whenever an OWTS is serviced for the purpose of septic tank pumping, pumping of the tank and visual inspection of the tank, pumps, visible piping and dispersal field area shall be made by the pumper as follows.
 - a. All compartments of the septic tank shall be pumped of all scum and sludge by a certified septic tank pumper.
 - b. The septic tank shall be inspected for signs of damage, deterioration, corrosion, leakage, blockages, high liquid level or other deficiencies.
 - c. Any pumping systems that are part of the OWTS shall be tested for proper operation and inspected for any deficiencies in the pump/sump tank, pump unit, piping, valves or control systems.
 - d. The dispersal field shall be inspected for indications of system failure such as flooded trenches, soil saturation or surfacing sewage, backflow of water into the septic tank, down-slope seepage, erosion or drainage problems, or other deficiencies.

4. **Septic Inspection Report.** For every septic tank pumped and inspected as described above, a written report on form(s) provided by Environmental Health shall be completed by the registered septic tank pumper and shall be submitted to Environmental Health and the property owner no later than 30 days following septic tank pumping. At a minimum, the report must include the following.
 - a. The name of the property owner, the street address of the property where the OWTS is located, and the date of servicing.
 - b. The name of the septic tank pumper, size of the septic tank(s), gallons pumped, the name and location of the disposal site, and a description of servicing activities.
 - c. A description of any OWTS maintenance performed.
 - d. A description of any failure or uncorrected deficiencies in the OWTS. Reported deficiencies shall include, but not be limited to, deteriorated, corroded or damage septic tank components; deficiencies in the condition or operation of any pumping systems; dispersal field problems such as surface failure, flooded trenches, down-slope seepage, backflow of effluent from the dispersal system into the septic tank; existence of a cesspool; and/or other deficiencies.

5. **Monthly Septic Tank, Holding Tank and Portable Toilet Pumping Statement.**
All certified pumpers shall file a monthly statement with Environmental Health,



giving the name and address of the owner or tenant of each of the premises where an OWTS, holding tank or portable toilet has been cleaned out by said pumper, his employees or others on his behalf. This statement shall also describe the place where the cleanings have been disposed.

F. ENVIRONMENTAL HEALTH REVIEW FOR PLANNING OR BUILDING PERMITS

San Mateo County Planning and Building Department, as well as Town of Woodside, Town of Portola Valley and City of Half Moon Bay planning and building departments, refer projects for review by Environmental Health that may require a new OWTS or that may affect an existing OWTS. For projects referred through County Planning and Building, Environmental Health review fees are paid through the Planning and Building Department. For projects referred through town or city planning and building departments, a separate Environmental Health Review Application with applicable fee must be submitted prior to Environmental Health staff review of the project.

Projects that do not include a new OWTS or repair to an existing OWTS, may still be referred to Environmental Health for review because the proposed project may affect an existing OWTS (i.e., a deck that may impinge upon the location of an existing OWTS or the reserved replacement area for an existing OWTS). For projects that do include a new OWTS or repair to an existing OWTS, it is at the planning/building permit review stage that Environmental Health typically reviews an OWTS project for any conflict with proposed improvements related to grading, drainage, other utilities, hardscape, landscape, etc. Note that, depending on the scope and stage in the planning/building permit process, this may require submittal of a septic system design that relies on having already completed site exam and soil percolation testing.

Environmental Health approval of a planning application or a building permit does not constitute a permit to construct/install an OWTS. See below for OWTS installation permit information.

G. INSTALLATION PERMIT REQUIREMENTS

An OWTS is required for all new residential or commercial facilities which are unable to connect to a sanitary sewer. For a new septic system, a Site Exam and Soil Percolation Test must be completed prior to the submittal of a Septic Installation Permit Application.

1. Site Exam

- a. An application for a site exam and soil percolation test must be completed and submitted with appropriate fee. This application must include:



- (1) Owner's name, address and phone number;
 - (2) Assessor's Parcel Number (APN);
 - (3) Address and/or location of property upon which the septic system is to be installed;
 - (4) Owner's signature or Letter of Agent Authorization, signed by the property owner, if necessary;
 - (5) Contractor information and signature; and
 - (6) Topographic map showing proposed locations for soil percolation test holes and deeper hole(s) for evaluation of soil and depth to groundwater, as well as identifying all relevant setbacks and any slopes of $\geq 50\%$ (and $\geq 35\%$ for sites in Town of Woodside). Note: this may require mapping beyond property line to show relevant setbacks.
- b. Environmental Health staff will evaluate the proposed soil percolation test and deeper hole(s) locations and give any needed feedback to the applicant.
 - c. An appointment to investigate the site must be made with Environmental Health staff at least two (2) working days in advance of any field work.
 - d. During the site exam, the proposed location of the soil percolation test holes, deeper hole(s) for evaluation of soil and depth to groundwater (and potential OWTS) will be confirmed, and if acceptable, presoak of the soil percolation test holes can commence. Note that a Qualified OWTS Design Professional must be onsite to, at a minimum, make observations required for the soil profile from the deeper hole(s).
 - e. During the site exam, Environmental Health will make a preliminary review of compliance with minimum depth to groundwater criteria and assess the need for wet weather groundwater observations per requirements detailed in Section 2 of this Manual.
 - f. Applications for which a permit has not been issued due to failure to submit required information shall become null and void after one year from the date the application was submitted.

2. Soil Percolation Test

- a. An application must be completed and submitted with appropriate fee (see above for Site Exam).



- (1) A soil percolation test must be conducted by a County Environmental Health Certified Soil Percolation Tester to investigate the absorption capability of the soil in which the OWTS is proposed to be installed.
- (2) All soil percolation tests must be conducted in accordance with the guidelines stipulated in Section 2 of this Manual.
- (3) Environmental Health staff must field-verify both the pre-soak and the soil percolation test; otherwise neither are considered valid and must be repeated. Soil percolation test-hole presoak is typically performed during the afternoon prior to the soil percolation testing during the Site Exam, as described above.
- (4) With permission from Environmental Health staff, soil percolation testing may commence prior to arrival of Environmental Health field inspector observing the soil percolation testing. However, Environmental Health staff must be present for at least the final three (3) readings collected. All readings taken during the soil percolation test must be submitted to Environmental Health for incorporation in the site file.
- (5) For the soil percolation rate to be considered “stabilized”, variation in last three readings must be as follows.
 - For maximum readings up to 1-inch in last ½-hour, three readings must vary by less than 35% of maximum of the three readings.
 - For maximum reading greater than 1-inch and less than 5-inches, three readings must vary by less than 25% of maximum of the three readings.
 - For maximum reading greater than 5-inches in last ½-hour, three readings must vary by less than 15% of maximum of the three readings.
- (6) The soil percolation rating (size) for the area represented by the soil percolation test holes, to be used in design of the OWTS, will be determined by Environmental Health staff, as described in Section 2 of this Manual, once the soil percolation test has been completed. This information will be provided in writing, and must be included on any plot plans with the application for the installation permit.
- (7) If the slope of the area tested is greater than 20%, a geotechnical report will be required. Details of geotechnical investigation and reporting requirements are included in Section 2 of this Manual. The report must be included with the submittal of the application for the OWTS Installation Permit.



(8) Applications for site exam or soil percolation testing, for which the work has not been completed, shall become null and void after one year from the date of application submittal.

3. OWTS Installation Permit Application

- a. An application for a permit to install an OWTS must be completed and submitted for review and approval by Environmental Health staff. Incomplete applications may be returned with plans as un-reviewed. Currently, installation permit fees are based on the size of the home(s) to be served. It is our intent that the fees will be updated in the near future to be based on the length of leach trench to be installed.
- b. Proposed OWTS design must be certified by a Qualified OWTS Design Professional as defined in the County OWTS Ordinance (Registered Environmental Health Specialist, Professional Geologist, or Professional Civil Engineer).
- c. OWTS can only be installed by a County Environmental Health Certified OWTS Installer (listed as contractor on permit application).
- d. Applications must be submitted with:
 - (1) Scaled (1 inch to 40 feet minimum, base 10 preferred) plot plan of the property and adjacent areas, as needed, indicating:
 - Topographic contours of the property (minimum 2 foot increments);
 - Footprint of all existing and proposed site structures, hardscape, grading and drainage;
 - Locations of the soil percolation test holes and the deeper soil and groundwater characterization holes;
 - Proposed location and design of the OWTS, including both primary and reserve trenches, septic tank, piping, and diversion valve(s);
 - Location of well(s), both on property and on adjacent properties; and
 - Any other limiting features (i.e., trees) or item covered by the setback requirements in the County OWTS Ordinance (Topography and structures adjacent to the subject parcel may be required to establish all appropriate setbacks).
 - (2) Completed Coastal Development Permit, if required by the San Mateo County Planning Department or Half Moon Bay Planning Department.
 - (3) Letter of Agent Authorization signed by the property owner, if necessary.



- e. Applications, for which a permit has not been issued due to failure to submit required information, shall become null and void after one year from the date of application submittal. No fees will be refunded once received by Environmental Health.

4. Installation Permit Requirements

- a. OWTS must be installed in accordance with the plans approved by Environmental Health. Any changes in the installation plans must be reviewed and approved by Environmental Health prior to installation.
- b. Inspection by Environmental Health staff of an OWTS being installed shall occur both prior to and during the installation. Critical inspections points include:
 - (1) Stake out of proposed trench locations;
 - (2) Inspections of empty (no rock) leach trenches for condition and total depth;
 - (3) Inspection of installed perforated drainpipe over drain rock in trenches;
 - (4) Location and proper installation of diversion valve(s); and
 - (5) Location and proper installation of septic tank(s).
 - (6) Location and proper installation of supplemental treatment units and/or pumps.
- c. OWTS must be constructed in accordance with requirements stipulated in the County OWTS ordinance and this Manual, as applicable.
- d. Permits shall expire and become null and void if the work authorized has not commenced within one (1) year after the permit has been issued. No fees will be refunded once received by Environmental Health. A permit extension may be granted if application for extension is made and appropriate fee paid, prior to the expiration of the original permit.

Additional details regarding the above are provided in this Manual as follows:

- **Section 2 – Site Investigation Requirements and Procedures**
- **Section 3 – Design and Construction Requirements for Conventional OWTS**
- **Section 4 – Alternative OWTS Requirements**



H. OWTS SUBJECT TO CRWQCB WASTE DISCHARGE REQUIREMENTS

OWTS that are subject to the requirements and approval of the CRWQCB are also required to obtain approval of Environmental Health in accordance with the following:

1. The proposed system must be designed to accommodate the waste discharge consistent with the requirements of the appropriate CRWQCB;
2. Environmental Health will require engineered sewerage plans to be submitted by a qualified professional with experience in OWTS design before issuing a permit;
3. A qualified professional will be required to inspect the construction of the OWTS and, upon completion, to submit a letter of certification to Environmental Health verifying the proper installation and operation of the OWTS;
4. Site evaluations, plan submittals, design and construction details, inspection, and operation and maintenance shall be consistent with guidelines and procedures prescribed by County Ordinance and prescribed in this manual.
5. The applicant must obtain a permit(s) from Environmental Health and pay a permit fee(s) in an amount established in County Ordinance Section 5.64.070.

I. OVER 50% REMODEL OR ADDITION OF A BEDROOM

For a building remodel that is 50% or greater the value of a structure¹ served by an existing OWTS, or remodel that includes addition of a bedroom served by an existing OWTS, all elements of the OWTS must meet the standards required by current County OWTS ordinance. This may require installation of additional leach trenches, installation of a larger or additional septic tank, and/or soil percolation testing (including determination of depth to groundwater).

1. **Condition of Existing OWTS.** In order to establish the condition of an existing OWTS, the following may be required:
 - a. Plans must be submitted and include information showing the location of the septic tank, drainfields and expansion area in sufficient detail to confirm no encroachment upon required setbacks.

¹ Specific to the unincorporated County projects based on County Planning and Building policy. Other jurisdictions' Building Department may have different requirements.



- b. Environmental Health will require that the existing septic tank be pumped, inspected and the drainfields undergo a hydraulic load test as appropriate to the requirements of the Planning and Building Department of record and based on the age and construction of the system.
- c. A hydraulic load test of the OWTS must be performed by a County Environmental Health Certified septic tank pumper, recognized maintenance provider, or other qualified professional. A report of the testing shall be submitted addressing the following:
 - (1) Size of the tank and type of construction material;
 - (2) Condition of the tank, baffles and tees;
 - (3) Length of the test. A minimum of 20 minutes required;
 - (4) If the drain fields were functioning (taking water) or if the drain fields failed to take water or result in surfacing of water/effluent;
 - (5) Condition of the diversion valve; and
 - (6) The tester shall indicate on the report if the house appears to be vacant.
- d. If the existing OWTS complies with current septic regulations, but is found to have deficiencies that constitute a threat to public health and safety, Environmental Health staff will require that the system be repaired under permit.
- e. A soil percolation test may be required to determine the adequacy of soil conditions in the area of the existing septic system.

2. OWTS Expansion or Repairs. Where findings from evaluation of the existing OWTS indicate the need for system expansion or repair to accommodate the proposed remodel or bedroom addition(s), the following shall be required:

- a. Site exam as described in Section C.1 above;
- b. Soil percolation testing will be required if the area in which additional leach trenches are proposed, has not been tested, if the soil percolation information is not available or verifiable by Environmental Health staff, or existing soil percolation information is considered no longer representative of site conditions. Soil percolation tests must be conducted and verified as described in Section C.2 above;
- c. Additional leach trenches must be installed and verified as described in Section C.4 above; and



- d. A permit, per Section C.3 above, must be obtained from Environmental Health for retrofit of existing leach trenches, installation of additional leach trenches, and installation or replacement of septic tanks. Existing wooden septic tanks do not meet current septic code and must be replaced with appropriate septic tanks.

J. UNDER 50% REMODEL WITH NO BEDROOM ADDITION

For building remodels that are less than 50% the value of the existing home as described above, or for those buildings as determined by the Planning and Building Department of record, for which no bedroom addition is proposed, the following may be required (especially for those properties with no or limited record of the existing OWTS on file with Environmental Health):

1. Submittal of plans showing detail of the existing septic system. For systems for which installation permits were issued after December 1969, 100% reserve distribution area must be designated. For systems for which installation permits were issued prior to December 1969, 50% reserve distribution area must be designated (consistent with requirements of that earlier septic ordinance).
2. Hydraulic load test of the existing septic system by a San Mateo County Certified Septic Tank Pumper, recognized maintenance provider or other qualified professional.

K. SECOND DWELLING UNITS

Second Dwelling Units have varying definitions in different planning/building jurisdictions of the County. Each Second Dwelling Unit shall be served by an OWTS, which conforms to current OWTS code. This may be a separate OWTS serving only the second dwelling, or the second dwelling may be connected to the main house OWTS, provided there is sufficient treatment and dispersal capacity.

For second dwelling units of up to 2 bedrooms that share an OWTS with the main house, whether detached or attached (having a shared wall, but not necessarily a direct access between the main house and second dwelling), the septic tank and dispersal system will be sized based on the number of bedrooms for both the main house and second dwelling. For existing main house OWTS, this may require modifications or expansion of existing septic tank and/or leach trench capacity.

For second dwelling units of up to 2 bedrooms that have their own separate OWTS from the main house, whether detached or attached, the septic tank and dispersal system will be sized based on the number of bedrooms served and measured soil percolation rate



as described in Section 3, D. and E. This instance of second dwelling units is the only instance in which OWTS dispersal systems for residential use will be considered less than the minimum (up to 3 bedrooms) OWTS dispersal systems.

Therefore, the following requirements apply to applications for the addition of a second dwelling unit at properties served by an existing OWTS.

1. If connection to a sanitary sewer system is not available, any proposed second unit addition would have to comply with current County regulations relating to OWTS.
2. If the second unit is within the structure of the main house, the addition would be treated in the same manner as a bedroom addition, and subject to OWTS requirements per Section 1.D. (over 50% remodel or addition of a bedroom) above, which may include modifications or expansion of septic tank and/or leach trench capacity.
3. If the second unit is detached from the main house, the waste plumbing may be connected by gravity to the main house OWTS as long as it can be accomplished with gravity flow to the existing septic tank and sufficient capacity is provided for the additional sewage flow from the proposed second unit per Section 1.D. above.
4. For detached second units where gravity flow to the main house system is not possible, a new OWTS meeting County regulations may be required for the second unit. If local planning and building department allows, a septic tank-effluent pump (STEP) system designed to pump effluent from the second unit septic tank to the main house OWTS may be considered but may require a variance.
5. Where a separate OWTS is required for a detached second unit addition, minimum requirements shall include the following:
 - a. Site exam, soil profile, groundwater determinations, soil percolation testing, and, where applicable, geotechnical slope stability analysis (>20% slope);
 - b. New 1,500-gallon septic tank as per Section 3.D.
 - c. New effluent dispersal systems as described in Section 3.E.; an
 - d. Identification of 100% reserve dispersal field area.



6. All other County requirements, including, but not limited to, permit fees and plot, plans would apply to second dwelling unit additions.

L. REPAIR OF EXISTING OWTS

All repairs or alterations to existing OWTS that were not required to meet the standards of new OWTS must comply as closely as practical with current OWTS requirements, and must be protective of human health and the environment. An exemption application with corresponding fee may be required by Environmental Health. Additionally, all repairs to an existing OWTS, including septic tank replacements, must be conducted under permit with Environmental Health and verified by Environmental Health staff as described above in Sections C.3 and C.4 above.

Replacement of a septic tank in the same location as previous tank is typically considered a minor repair/alteration.

The following, occurring individually, are considered a major repair/alteration:

- Installation of a replacement septic tank in a new location,
- Installation of any new leach trenches adding to an existing system, where the total length of new leach trenches installed is less than 100 linear feet,
- Alteration of any existing leach trenches where rock is removed and trench is deepened, requiring inspection of the trench bottom, where the total length of trench being deepened is less than 100 linear feet.

Any combination of the above, as well as any leach trench installation or alteration (as described above) totally more than 100 linear feet, is considered a new installation as is subject to the corresponding installation fee..

M. DESTRUCTION OF SEPTIC TANKS AND LEACH TRENCHES

OWTS, including septic tanks, can either be completely removed or properly abandoned in-place. Destruction of any element of an OWTS must be conducted under permit with Environmental Health and verified by Environmental Health staff. Permit application for septic system destruction must include the proposed method of destruction/disposal for all elements of the system.

1. **Septic Tanks.** Septic tanks can either be completely removed and properly disposed of or abandoned in place. In either case, both chambers of the septic tank must be pumped out by a pumping company certified to work in San Mateo County and the sewage must be disposed of in an approved manner.



2. **Complete Removal.** After pumping of residual sewage as described above, the septic tank must be rinsed, pumped of its rinsed water, and completely removed from the ground. The tank can then be recycled or disposed of depending upon the construction materials.
3. **Abandonment In-Place.** After pumping of residual sewage as described above, the following steps must be completed:
 - a. The bottom of the empty septic tank must be broken-up or perforated to allow for bottom drainage;
 - b. The septic tank must be filled in with sand, native soil, or other approved material, and the material must be compacted as appropriate; and
 - c. The top of the septic tank must be removed or collapsed.
4. **Leach Trenches.** Leach trenches can be removed, although such removal may not be necessary. If leach trench removal is necessary (i.e. for future construction or for geotechnical stability), such removal should be conducted as follows, or as may be modified in accordance with recommendations provided by a geotechnical professional:
 - a. Drainpipe (and conveyance pipe) removed and properly disposed;
 - b. Drain rock removed to the extent practicable and properly disposed; and
 - c. Trenches backfilled with native soil or other geotechnical appropriate material, and the material compacted as appropriate.

Appropriate erosion control measures must be employed during any excavation or earth movement activities.

N. SUBDIVISIONS AND LOT LINE ADJUSTMENTS

For subdivisions and lot line adjustments, each proposed lot shall be evaluated separately to verify OWTS suitability for each proposed developed or undeveloped lot. At a minimum:

1. Site examination and soil percolation testing for each proposed lot;
2. Demonstration that a legal minimum (3-bedroom) system, consistent with the actual soil percolation rate, meeting all requirements of the County OWTS Ordinance and this Manual, can be designed/installed for each proposed lot (with no exemptions allowed per OWTS Ordinance Section 4.84.185);
3. Each developed parcel(s) within a proposed subdivision or lot split will be evaluated to determine if the existing OWTS meets the required setbacks; and



4. Verify that the system is functioning adequately.

O. PROPERTIES NEAR A SANITARY SEWER SYSTEM

On property where there is an existing OWTS and where the structures served by the OWTS are within two hundred (200) feet of an approved available sanitary sewer, connection to the sanitary sewer will be required when addition to the OWTS is required or proposed or a major repair is required or proposed, provided any necessary approval from the planning and building department of record, the appropriate sewer authority and the San Mateo County Local Agency Formation Commission is first obtained.

P. ALTERNATIVE SYSTEMS

Alternatives to conventional OWTS may be used as detailed in Section 4.84.145 of County OWTS Ordinance, to provide a broader range of OWTS treatment and dispersal options for new construction and repair/replacement situations. These alternative systems may be allowed in accordance with certain general provisions and specific requirements as follows.

1. General provisions.

- a. Types of alternative systems permitted are limited to those for which siting and design standards have been adopted and incorporated in the County OWTS Ordinance and this Manual.
- b. All alternative systems must be installed by a contractor duly licensed by the Contractors State License Board of the State of California to install OWTS.

2. Specific Requirements

- a. **Design and Installation Permit.** Alternative OWTS require design by a licensed professional and completion of site evaluation and installation permitting as required for conventional OWTS. Additional engineering and design requirements applicable to different types of alternative OWTS are contained in Section 4 of this Manual.
- b. **Operating Permits.** A County-issued operating permit is required for all alternative systems. Operating permits are intended to serve as the basis for verifying the adequacy of alternative system performance and ensuring on-going maintenance, including requirements for system inspection, monitoring and reporting of results to Environmental Health, along with the requirement for permit renewal, typically on an annual basis. An OWTS operating permit gives Environmental Health right of inspection. In addition,



- failure to comply with requirements of an OWTS operating permit may subject the system owner or user to administrative enforcement and fines.
- c. **Performance Monitoring and Reporting.** Performance monitoring and reporting is required for all alternative OWTS in accordance with conditions established by Environmental Health as part of the operating permit. Performance monitoring requirements are covered in Sections 4 and 5 of this Manual.
 - d. **Design and Construction Guidelines.** Design and construction guidelines for approved alternative treatment and dispersal technologies are provided in Section 4 of this Manual.

Q. OPERATING PERMITS

A County-issued operating permit is required for all alternative systems, as well as for septic holding tanks (which have been granted exemptions to occur) and some portable toilet installations as described in Section 4.84.110 of County Ordinance code. Operating permits are intended to serve as the basis for verifying the adequacy of performance and ensuring on-going maintenance, including requirements for inspection, monitoring and reporting to Environmental Health, along with the requirement for permit renewal, typically on an annual basis. An operating permit gives Environmental Health the right of entry and inspection. In addition, failure to comply with requirements of an operating permit may subject the permit holder (whether owner or user) to administrative enforcement and fines.

R. EXEMPTIONS (VARIANCE)

An exemption from the terms of the OWTS Ordinance or this Manual may be granted by Environmental Health under those conditions as described in Section 4.84.185 of the OWTS Ordinance.

Application for an exemption shall be made by submitting a permit application, required fee, and all other plans and documents as may be required by Environmental Health staff in support of the request for exemption. The request for exemption will be evaluated by Environmental Health Land Use staff, and presented to the Director of Environmental Health for concurrence or denial.



S. AMENDMENTS TO THIS MANUAL

Environmental Health will periodically review and make amendments to the various procedures and technical information contained in this Onsite Systems Manual, typically on an annual or biannual basis. The amendments may include recommended changes originating from Environmental Health staff, RWQCB staff, other departments or agencies, contactors and consultants working in the OWTS industry, or other affected groups or individuals. Any substantive changes in requirements, such as changes in design criteria or addition of alternative design options, are expected to involve review and approval by the RWQCB as an update to the County LAMP.

The general format for considering changes to this Manual are as follows:

1. Environmental Health will announce its intent to entertain and review proposed changes, including a due date for submission of proposals. Environmental Health may establish, with Board of Supervisors approval, a fee to be charged for proposals that relate to proprietary equipment, systems or materials.
2. Proposals received shall include a description of the proposed change(s) along with supporting rationale, technical information, and specific language/text additions or changes.
3. Environmental Health will conduct a preliminary internal review to determine the completeness and general merit of the proposal, and request additional information, as applicable.
4. Environmental Health will circulate the proposal(s) for review by local consultants, contractors and maintenance providers, environmental groups and other stakeholders as deemed appropriate. Environmental Health will convene a workshop-meeting with interested parties to review and discuss the proposal.
5. Based on the Environmental Health review and workshop findings, proposals acceptable to the Director and warranting further consideration will be forwarded to the RWQCB for review and approval; changes will be incorporated following RWQCB approval.



FORMS AND FIGURES



SEPTIC APPLICATION CHECK LIST

*Application(s) that are not completely filled out will not be processed.

Application(s) must be:

- ▶ Legible
- ▶ Complete with current application (filled out and signed)

check box indicating the service(s) applying for

APN (Assessor Parcel Number)

Mailing Address & Site Address (street, city and zip)

Applicant / Agent's Signature (Attach a letter from the property owner providing authorization if signed by an Agent.)

Contractor's Information and Signature

Submit with a form of payment.

cash (over the counter only), check (made to San Mateo County) or credit card (visa, mastercard)

3 surveyed plot plans with topography, must graphically indicate slopes greater than or equal to 50%. Make plans to scale 1" = 20' preferred (not required for permit extension or tank destruction)

Method of Abandonment/Destruction on separate sheet (required for tank destruction)

SEPTIC APPLICATION FOR INDIVIDUAL SEWAGE DISPOSAL SYSTEM PERMIT

ALL WORK MUST BE SCHEDULED WITH ENVIRONMENTAL HEALTH STAFF AT LEAST 2 WORKING DAYS IN ADVANCE

NEW CONSTRUCTION: (check one or more)		Fees must be submitted with application
<input type="checkbox"/> PE 4218 Site Exam	<input type="checkbox"/> PE 4211 Tank Destruction *	<input type="checkbox"/> PE 4260 Filing Fee / Water Test
<input type="checkbox"/> PE 4220 Perc Test	<input type="checkbox"/> PE 4225 Permit Appeal	<input type="checkbox"/> PE 4216 Wet Weather Testing
<input type="checkbox"/> PE 4219 Repair/Alteration		<input type="checkbox"/> PE 4208 Alternative / Pres Dose Annual
<input type="checkbox"/> PE 4214 Tank Replacement in same location (Minor Repair)		<input type="checkbox"/> PE 4213 Alternative System (in addition to Installation permit fee)
Installation Permit: (check one)		<input type="checkbox"/> PE 4212 Exception / Variance
<input type="checkbox"/> PE 4221 <2500 feet ² House Size		<input type="checkbox"/> PE 4217 Permit Extension: _____
<input type="checkbox"/> PE 4223 <3500 feet ² House Size		<input type="checkbox"/> PE 4210 Re-submittal: _____
<input type="checkbox"/> PE 4224 >3501 feet ² House Size		<input type="checkbox"/> PE 4209 Annual Certification of Perc Tester or Installer

SITE INFORMATION			
SITE ADDRESS: _____		City _____	Zip _____
APN: _____		(9 digit number required) Building Application #: _____	
NUMBER OF BEDROOMS _____	ADDITION TO HOUSE <input type="checkbox"/> YES <input type="checkbox"/> NO	SOURCE OF WATER SUPPLY: <input type="checkbox"/> PUBLIC WATER	<input type="checkbox"/> WELL <input type="checkbox"/> SPRING

OWNER INFORMATION			
OWNER _____			
Mailing Address: _____		City: _____	Zip: _____
Phone: _____		Email: _____	

CONTRACTOR INFORMATION (MUST BE CERTIFIED SEPTIC CONTRACTOR)			
CONTRACTOR: _____		Contractor License No. _____	
Mailing Address: _____		City: _____	Zip: _____
Phone: _____		E-Mail: _____	

San Mateo County Certified Percolation Tester No. OR Installer No _____

Workmen's Compensation Insurance Coverage: _____

I certify that I have valid Workmen's Compensation Coverage or that I shall not employ any person in a manner so as to become subject to California Workmen's Compensation Laws for the work for which this permit is being requested.

Contractor Signature: _____ Date: _____

Property Owner/ Agent Signature: _____ Date: _____

(Attach a letter from the property owner providing authorization if signed by an agent)

3 surveyed plot plans MUST be submitted with this application. (Make plans to scale 1" = 20' preferred)
*Submit Method of Tank Abandonment/ Destruction on a separate sheet.

APPLICATION WILL BE VOID AFTER 1 YEAR FROM DATE OF SUBMITTAL

LANDUSE Program Element Fee Guide/Schedule



PE 2699- Landuse Services/Hour	\$167.00
PE 2667- Building Permit Review/Hour	\$834.00
PE 2656- Planning Application Review	\$834.00
PE 4210- Resubmittal Fee	\$834.00
<u>WELL</u>	
PE 4666- Well Drilling Permit	\$1376.00
PE 4667- Well Abandonment/Destruction	\$697.00
PE 4668- Certification (Pump Test)	\$1394.00
PE 4670- Well Permit Extension (1 year)	50% Current Fee
PE 4672- Permit to Operate	\$1533.00
PE 4678- Well Exception/Variance	\$697.00
PE 4699- Other (Change of Contractor, hourly review/consultation)	\$167.00
<u>Ground Source Heat Exchange Well Bores:</u>	
PE 4686- from 1 to 3 bores	\$1376.00
PE 4687- from 4 to 8 bores	\$2751.00
PE 4688- from 9 to 13 bores	\$4127.00
PE 4689- from 14 to 19 bores	\$5502.00
PE 4690- from 20 to 29 bores	\$6878.00
PE 4691- from 30 to 39 bores	\$8253.00
PE 4692- from 40 to 49 bores	\$9629.00
<u>SEPTIC</u>	
PE 4208- Alt/ Press Dosed Annual	\$434.00
PE 4209- Certification Fee (Soil Perc Tester/Installer)	\$52.00
PE 4211- Tank Destruction	\$881.00
PE 4212- Septic Exception/Variance	\$697.00
PE 4213- Alternative Systems	\$5003.00
PE 4214- Septic Tank Replacement (Same Location)	\$881.00
PE 4216- Wet Weather Test	\$960.00
PE 4217- Septic Permit Extension (1 year)	50% Current Fee
PE 4218- Site Exam	\$1009.00
PE 4219- Repair/Alteration	\$1601.00
PE 4220- Perc Test	\$1836.00
PE 4221- Installation Permit <2500 ft ² House Size	\$1836.00
PE 4223- Installation Permit <3500 ft ² House Size	\$2794.00
PE 4224- Installation Permit >3501 ft ² House Size	\$3839.00
PE 4225- Permit Appeal	\$288.00
PE 4226- Inspection Cancellation	\$348.00
PE 4244- Septic Pumper Vehicle (Annual)	\$640.00
PE 4245- Business Registration Annual (Septic Pumper)	\$1416.00
PE 4260- Filing Fee/Water Test	\$37.00
PE 4299- Other (Change of Contractor, hourly review/consultation)	\$167.00



SEPTIC PUMPER TRUCKS and BUSINESS APPLICATION

Check box: (see Land Use Fee Guide/Schedule for Fee)

Total Amount Paid \$ _____

- (PE 4244) Annual Fee per Vehicle Operating in San Mateo County \$640.00 X _____ = \$ _____
of Vehicles
- (PE 4245) Annual Fee for Septic Pumper Business Registration \$1416.00
- Will NOT be Engaging in any Business within San Mateo County

Application for registration to engage in the business of cleaning septic tanks, chemical toilets, etc. As issued in accordance with Sections 25000 to 25010 of the State Health & Safety Code and San Mateo County Ordinance Code, Chapter 4 Section 9340

BUSINESS NAME		PHONE #
OWNERS NAME		FAX #
MAILING ADDRESS		
CONTACT PERSON	EMAIL ADDRESS	

Names & Addresses of Partner(s):

List Vehicles Operating in San Mateo County (use additional paper if needed)

Year	Make	License Number	Capacity in Gallons

Is the Business Name, Address, Telephone Number & Capacity in Gallons printed on both sides of truck, with letters at least four inches high? Yes No

Location of discharge: _____

The undersigned agrees to conform to all conditions, orders and directions issued pursuant to above laws and to furnish monthly reports to all work done in County of San Mateo to the Environmental Health Services Division.

Signature: _____ **Date:** _____

**SAN MATEO COUNTY ENVIRONMENTAL HEALTH
SEPTIC TANK AND CHEMICAL TOILET CLEANERS REPORT**

COMPANY NAME: _____

COMPANY ADDRESS: _____

REPORT FOR THE MONTH OF: _____ 20____

DATE:	NAME OF PROPERTY OWNER	ADDRESS WHERE WORK WAS COMPLETED	GALLONS PUMPED	WHERE CLEANING WERE UNLOADED

**Return by the 12th of each month to
County of San Mateo
Environmental Health Services Division
2000 Alameda de las Pulgas, Suite 100, San Mateo, CA 94403**

L:\Land Use\ FORMS\APPLICATIONS\SEPTIC - PUMP Revised August 2015 Septic Pump Standard App.doc
Updated: 8/01/2015



San Mateo County Environmental Health Services Division
 Phone (650) 372-6200
 Fax (650) 627-8244

2000 Alameda de las Pulgas, Suite 100
 San Mateo, CA 94403
www.smchealth.org/landuse

SEPTIC TANK PUMPING AND INSPECTION REPORT

PUMPER COMPANY NAME: _____

JOB LOCATION: _____ **APN:** _____

OWNER: _____ **REQUESTED BY:** _____

REASON FOR PUMPING/INSPECTION:

MAINTENANCE HAULAWAY SALE INSPECTION SYSTEM FAILURE REPAIR OTHER _____

SLUDGE DISPOSAL LOCATION: _____

PROPERTY USE: HOME OTHER _____ OCCUPIED? YES NO

SEPTIC TANK: SIZE _____ GALLONS PUMPED _____ BOTH COMPARTMENTS PUMPED? YES NO

TYPE: REDWOOD _____ CONCRETE _____ POLY _____ FIBERGLASS _____ OTHER _____

CONDITION OF TANK	GOOD	FAIR	POOR	REPAIRS RECOMMENDED
SEPTIC ELLS/TEES				
TANK TOP AND/OR LIDS				
SIDES/BOTTOM OF TANK				
BAFFLES				

OPERATIONAL LEVEL: HIGH _____ LOW _____ NORMAL _____ DATE LAST PUMPED: _____

LEACHING SYSTEM

PRESENT OR PAST HIGH LEVEL IN TANK YES NO

LIQUID FLOWBACK WHILE PUMPING? YES NO

SIGNS OF SURFACING EFFLUENT ? YES NO

SEPARATE GREYWATER DISCHARGE? YES NO TO SUMP ONTO GROUND

OTHER SYSTEM COMPONENTS/NOTES:

SYSTEM LOCATION (SKETCH OR DESCRIBE, WITH MEASURED DIMENSIONS AND DIRECTION OF NORTH; INCLUDED ANY PERTINENT FEATURES SUCH AS PAVED AREAS, SURFACING EFFLUENT, CREEKS, LARGE TREES, ETC.)

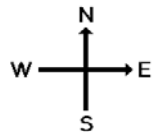

INSPECTION DATE: _____

INSPECTED BY: _____



COUNTY OF SAN MATEO
 Environmental Health Services Division
 2000 Alameda de las Pulgas, Suite 100, San Mateo, CA 94403
 Phone (650) 372-6200 Fax (650) 627-8244

Environmental Health Review Application

**Fees subject to change*

Applicant:

Name: _____
 Site Address: _____
 City: _____ Zip: _____
 Phone #: _____

_____ Unincorporated
 _____ Incorporated

Assessor's Parcel Number(s)

TYPES OF REVIEW

Planning Application Review
 Planning App #: _____

Building Application Review
 Building App #: _____

Other _____

FEES

\$ 834.00
 (PE 2656)

\$ 834.00
 (PE 2667)

\$ _____

TOTAL: \$ _____

Property Owner:

Name: _____
 Address: _____
 City: _____ Zip: _____
 Home #: _____
 Business#: _____

Contractor/Architect:

Name: _____
 Address: _____
 City: _____ Zip: _____
 Phone #: _____

Detailed Description of Work _____

Owner or Authorized Representative: _____ **Date:** _____

Please submit check payable to San Mateo County with this review application. This application is for Environmental Health Review only. Additional permits, site inspections from this office will require additional applications and/or fees.

SECTION 2 SITE INVESTIGATION REQUIREMENTS AND PROCEDURES

CONTENTS

- A. SITE EVALUATIONS FOR OWTS
- B. SOIL PERCOLATION TEST PROCEDURES
- C. WET WEATHER GROUNDWATER OBSERVATIONS
- D. GEOTECHNICAL REQUIREMENTS
- E. CUMULATIVE IMPACT ASSESSMENT

ATTACHMENT A – GUIDELINES FOR CUMULATIVE IMPACT ASSESSMENT

FORMS AND FIGURES



SECTION 2 SITE INVESTIGATION REQUIREMENTS AND PROCEDURES

A. SITE EVALUATIONS FOR OWTS

Prior to approving the use of an OWTS, a site evaluation is required in all instances to allow proper system design and to determine compliance with the site suitability criteria specified in the San Mateo County OWTS Ordinance and this manual. Site evaluations shall be conducted by Environmental Health staff performed in accordance with the following general requirements and referenced attachments.

1. General Site Features

Site features to be determined by inspection shall include:

- a. Land area available for treatment components and for primary and reserve dispersal fields;
- b. Ground slope in the primary and reserve dispersal area(s) and in those areas within relevant setbacks of the proposed OWTS;
- c. Location of cut banks, fills, or evidence of past grading activities, natural bluffs, sharp changes in slope, soil landscape formations, and unstable land forms within 100 feet of the primary and reserve dispersal area(s);
- d. Location of wells, streams, and other bodies of water within 200 feet of the primary and reserve dispersal area(s); and
- e. To the extent possible, the location of existing OWTS within 100 feet of the primary and reserve dispersal area(s).

2. Soil Profiles

- a. Soil characteristics shall be evaluated by soil profile test pit observations. A minimum of one test pit in the most limiting area of the dispersal field area shall be required for this purpose. Additional soil profiles may be required if:
 - (1) the initial profile indicates conditions which do not provide sufficient information for design and/or determination of code compliance, or
 - (2) the area proposed for the dispersal fields cannot be adequately represented by a single soil profile test pit, or



- (3) it is determined by Environmental Health that additional soil profile test pits are needed.
- b. An augured test hole may be an acceptable alternative to a test pit where adequate soil profile can be determined given the limited visibility within the boring and where Environmental Health staff determines that:
 - (1) The use of a backhoe/excavator is impractical because of access or because of the fragile nature of the soils;
 - (2) It is necessary only to verify conditions expected on the basis of prior soils investigations; or
 - (3) It is done in connection with geotechnical investigations.
 - c. The following factors shall be observed and reported from the ground surface to a limiting condition, up to a minimum of three to five feet below the bottom of the proposed dispersal system. **Note that these observations must be made and reported by a Qualified OWTS Design Professional** (in compliance with California Business and Professions Code and California Health and Safety Code).
 - (1) Thickness and coloring of soil layers, soil structure, and texture according to United States Department of Agriculture (USDA) classification (see U.S. EPA Design Manual for Onsite Wastewater Treatment and Disposal Systems, 1980);
 - (2) Depth to a limiting condition such as hardpan, rock strata, impermeable soil layer, or saturated soil conditions;
 - (3) Depth to observed groundwater or soil mottling; and
 - (4) Other prominent soil features which may affect site suitability, such as coarse fragments, soil consistency, roots and pores, and moisture content.

3. Soil Percolation Testing

Determination of a site's suitability for dispersal of effluent and OWTS design shall be made by the completion of soil percolation testing in accordance with procedures detailed in Section 2.2.

4. Depth to Groundwater Determination

The anticipated highest level of groundwater in the primary and reserve area shall be estimated:



- a. Base on the highest extent of soil mottling observed in the examination of soil profiles; or
- b. By direct observation of groundwater levels during the time of year when the highest groundwater conditions are expected or known to occur, i.e., wet weather testing timeframe as defined by the Environmental Health (see Section 2.3 - Wet Weather Groundwater Observations).

Where there is a discrepancy between soil profile indicators (mottling) and direct observations, the direct observations shall govern.

5. Geotechnical – Slope Stability Analysis

For sites where the ground slope exceeds 20% or other geotechnical constraints exist, additional technical evaluation of slope stability, drainage, and other similar factors shall be required to verify that the proposed dispersal system will not degrade water quality, create a nuisance, affect soil stability or present a threat to the public health or safety (See Section 2.4 – Geotechnical Requirements).

6. Cumulative Impacts

For certain projects, typically non-residential and large flow OWTS, the completion of additional technical studies, termed “cumulative impact assessment”, may be required. This is to address the cumulative impact issues, mainly groundwater mounding and nitrogen loading, from OWTS that can result from such factors as the constituent levels in the wastewater (e.g., nitrogen content), the volume of wastewater flow, the density of OWTS discharges in a given area, and/or the sensitivity and beneficial uses of water resources in a particular location (See Section 2.5 – Cumulative Impact Assessment, and guidelines in Attachment A).

7. Reporting

All site evaluation information, including test results for primary and reserve dispersal areas, shall be submitted to the Environmental Health upon completion of the work (and a copy included with the OWTS installation permit application).

B. SOIL PERCOLATION TEST PROCEDURES



1. General

In accordance with the provisions of Section 4.84.115 of the San Mateo County Ordinance, the following standards have been developed for conducting percolation tests. Soil percolation testing must comply with these standards and the test results must satisfy the requirements for OWTS in Section 3 of this Manual before a permit to install/construct an OWTS will be issued or a building permit application approved.

Soil percolation tests other than those described below may be used with prior approval of Environmental Health, provided that such tests are verifiable and the results can be expressed in inches/hour for a twelve (12) inch deep test hole, twelve (12) inches in diameter.

2. Procedure for Standard 8-foot Deep Dispersal Trench

The following procedure shall be used where soil is acceptable for a drain field trench with a standard depth of eight (8) feet.

- a. The standard soil percolation test of Environmental Health involves a backhoe excavation to a depth of four (4) to five (5) feet, with a slanted end-wall for ingress/egress. A minimum of six (6) test holes per building site in the area to be used for dispersal fields shall be provided. Three (3) holes must be in the primary area and three (3) must be in the proposed reserve area.
- b. At the bottom of each excavation, a twelve (12) inch diameter hole must be dug to a depth of (12) inches.
- c. The sides of the hole must be scratched or roughened to remove smeared surfaces and all loose materials removed from the hole. Two (2) inches of coarse clean sand or fine gravel must be added to the bottom of the hole to protect the bottom from scouring and sediment.
- d. The 12-inch diameter hole must be filled with clear water and the water maintained in the hole for at least four (4) hours prior to the start of the test, normally on the afternoon of the day before the test. This presoak of the holes must be observed by Environmental Health staff.
- e. The test is begun by adding clear water to bring the depth of water to approximately eight (8) to ten (10) inches over the sand/gravel. From a fixed reference point, the drop in water level is measured at thirty (30) minute



intervals for four (4) hours, refilling six inches over the gravel as necessary. The drop that occurs during the final thirty (30) minute period is used to calculate the percolation rate. This rate must be a stabilized rate over the last three (3) readings. The testing shall continue until a stabilized rate has occurred. The final three (3) 30-minute intervals must be observed by Environmental Health staff.

- f. For the soil percolation rate to be considered “stabilized”, variation in last three readings must be as follows:
 - (1) For maximum readings up to 1 inch in last ½-hour, three readings must vary by less than 35% of maximum of the three readings;
 - (2) For maximum reading greater than 1-inch and less than 5-inches, three readings must vary by less than 25% of maximum of the three readings; and
 - (3) For maximum reading greater than 5-inches in last ½-hour, three readings must vary by less than 15% of maximum of the three readings.
- g. All soil percolation test holes, trenches and excavations must be filled upon completion of testing.
- h. All soil percolation test data shall be verified and submitted to Environmental Health staff upon completion of the test.
- i. The soil percolation rating (size) for the area represented by the soil percolation test holes, to be used in design of the OWTS, is determined by Environmental Health staff once the soil percolation test has been completed. This information will be provided in writing, and must be included on any plot plans with the application for the installation permit.

3. Auger/Drilled Method

A twelve (12) inch diameter hole drilled to a depth of six (6) feet may be used as an alternative soil percolation testing method. All other aspects of the soil percolation test are the same for this alternate method as described above for the standard test method. While this method will be accepted, the applicant or his agent should realize the difficulties inherent in this method, which are unfavorable to the successful conduct of the soil percolation test.



Care must be exercised in:

- addition of the two (2) inches of sand or fine gravel to the bottom of the hole six (6) feet deep so as to evenly cover and protect the bottom soil from erosion during the test;
- scratching or equivalent roughening of the bottom and side wall so as to return it to approximately the original percolation capacity since drilling usually causes a smearing or sealing of the borehole walls;
- introduction of water into the hole so as to avoid turbulence, erosion, and increased turbidity of the test water;
- construction of the borehole and the conduct of the test to avoid sloughing of soil from the sidewalls into the bottom of the borehole; and
- maintenance of a maximum depth of twelve (12) inches of water.

4. Soil Percolation Test Methods to Evaluate for Shallower Trenches

Both test methods as described above can be used for measuring percolation rates in soil for distribution trenches shallower than the standard 8-foot deep trench, including for mid-depth and/or chambered (rockless) trenches. However, the target depth at which to measure percolation rates may need to be shallower than the 4- to 6-foot depth range measure as described above. The targeted depth interval should be described and justified with the application for percolation testing for such projects.

5. Soil Percolation Test Methods to Evaluate for Shallow Subsurface Drip

There are a variety of methods for determining soil percolation rates and associated application rates when evaluating and designing for shallow subsurface drip distribution systems. While rough soil percolation rates and application rates can be estimated based on soil lithology and structure, it is always preferred that these rates are confirmed with direct-reading field measurements. Therefore, methods proposed to be used for direct-reading field testing of soil percolation rates and associated application rates must be submitted to Environmental Health for evaluation/approval prior to use.



6. Use and Interpretation of Results

For comparison with applicable OWTS standards, soil percolation test data from the various test holes should be evaluated and interpreted as follows:

- a. Calculate average of all test holes in inches per hour (also MPI) to verify that the rate falls within the acceptable range and to determine system design/sizing requirements.
- b. If there are one or two failing test results (i.e. too fast or too slow), three options are available:
 - (1) Include the failing result(s) in the calculated average and evaluate/design the system accordingly;
 - (2) Exclude the area represented by the failing test hole(s), and design the system according to the average of the other test holes. Split the difference between the locations of failing and nearby passing test holes to determine the area to be excluded; or
 - (3) Conduct additional testing in an alternate area or to refine the exclusion area represented by the failed test result(s).
- c. If there are more than two failing test results, additional testing will be required to define the limits of acceptable soil areas for the dispersal system.

7. Observation of Soil Percolation Test

Soil percolation test data must be verified and the soil percolation test card must be signed by a representative of Environmental Health to be valid. The person conducting the soil percolation test shall notify the Environmental Health office two (2) working days prior to the time of such test to permit Environmental Health staff to observe portions of the test as needed.

With permission from Environmental Health staff, soil percolation testing may commence prior to arrival of Environmental Health field inspector observing the soil percolation testing. However, Environmental Health staff must be present for at least the final three readings collected. All readings taken during the soil percolation test must be submitted to Environmental Health for incorporation in the site file.



8. Observation of Soil Conditions Three (3) to Five (5) Feet Below Proposed Standard Drainfield Trench Bottom

An eleven (11) to thirteen (13) foot deep test hole shall be excavated in the presence of Environmental Health staff to determine soil conditions three (3) to five (5) feet or greater below the bottom of the proposed dispersal trench. If it is determined that seasonal ground water conditions exist at a depth within three (3) to five (5) feet of the bottom of the proposed dispersal trench or field, wet weather or seasonal groundwater testing shall be required using methods described later in this section.

9. Reporting of Results

When a Qualified OWTS Design Professional submits data for review regarding onsite wastewater treatment and disposal systems, they shall interpret such soil percolation tests, borings and similar information in terms of conformance with current standards. The Qualified OWTS Design Professional shall also state that geological conditions, historical and seasonal ground water fluctuations, topography and other factors covered in the regulations have been investigated and based on this information, in their professional judgment, the OWTS will be in compliance with the County OWTS Ordinance and this Manual.

10. Soil Percolation Testing for Proposed Subdivision

A Qualified OWTS Design Professional shall submit all percolation test data for each of the proposed parcels of the subdivision. They shall interpret such soil percolation tests, borings and similar information in terms of conformance with current regulations. They shall also state fluctuations, topography and other factors covered in the regulations have been investigated and, based on this information, in their professional judgment, the OWTS will be in compliance with the County OWTS Ordinance and this Manual.

C. WET WEATHER GROUNDWATER OBSERVATIONS

County Ordinance Sections 4.84.120 and 4.84.165 specify minimum vertical separation requirements between the bottom of the dispersal trench and seasonal high groundwater levels. If general observations during soil percolation testing and evaluation of soil profile are not definitive of seasonal high groundwater conditions, wet weather testing may be required. Wet weather testing is designed to verify compliance with applicable groundwater separation requirements from base of effluent distribution to seasonal high groundwater.



Procedures for wet weather groundwater observations are as follows:

1. **Timeframe.** Wet weather groundwater observations during any given year:
 - a. can commence once 50% of the annual rainfall has been obtained for a particular area, as measured for the water year from October 1st – September 30th, per rainfall data as reported by the National Weather Service; and
 - b. can continue through March 20th of the water year, unless the observation period is extended by Environmental Health based on the rainfall conditions for the given year.
2. **Testing Methods.** Wet weather groundwater observations may consist of one of the following. Alternate methods other than those described below may be used, with approval of Environmental Health prior to the testing, provided that such methods are verifiable.
 - a. For immediate monitoring: An 11- to 13-foot deep hole shall be drilled or excavated under the supervision of a qualified professional, who will observe the static level of infiltration of groundwater (if any) in the hole; or
 - b. For extended monitoring, a piezometer (observation monitoring well) of appropriate depth and screened interval may be permitted through Environmental Health and installed at the site. Proper installation and abandonment of the piezometer must be completed under permit from Environmental Health.
3. **Where Required.** Determination of whether an area requires wet weather groundwater observations will be as follows:
 - a. When an area has been known to have shallow levels of groundwater, as previously observed; and
 - b. When conditions in the soil (i.e., mottling, moisture) indicate that shallow groundwater levels have occurred in the past.

D. GEOTECHNICAL REQUIREMENTS

OWTS dispersal systems, including repairs to existing dispersal systems, shall not be permitted where steep or unstable slopes, rock outcropping, cuts in banks, underground clay lenses or similar topographic and geologic conditions could be expected to result in the surfacing of the liquid effluent or cause instability in the slope. Requirements and investigation procedures established to ensure



appropriate consideration of geotechnical issues in the siting, design and operation of OWTS are described below.

1. **Ground Slope**

- a. Any OWTS dispersal system located on ground slope greater than 20% shall require the completion of a geotechnical slope stability study as described below under Geotechnical Report Requirements.
- b. For conventional (gravity) dispersal systems, maximum ground slope in the dispersal system area shall not exceed thirty-five (35) percent.
- c. Any dispersal system located on ground slope greater than 35% shall require the use of pressure distribution or subsurface drip dispersal to distribute the wastewater effluent uniformly throughout the dispersal area. Both of these dispersal methods fall in the category of "Alternative OWTS".
- d. No dispersal system will be permitted to be located where ground slope is 50% or greater.

2. **Proximity to Cuts, Embankments, and Steep Slopes**

- a. Dispersal systems shall not be installed where deep cuts exist, which can be expected to later cause sewage seepage from dispersal systems installed at a higher elevation.
- b. Dispersal systems shall be located in conformance with the following horizontal setbacks from geological/landscape features.
 - (1) Setback equal to 4 x height of a cut or embankment; the required setback distance shall be at least 25 feet and no more than 50 feet.
 - (2) Setback from Steep Slopes (lower in elevation than OWTS) shall be at least 25 feet where the height of the steep slope is less than 12 feet, and at least 50 feet where the height of the steep slope is greater than 12 feet. Steep slope is considered to be land with a slope of greater than or equal to fifty percent (50%). Where there is clearly discernable embankment and/or break in slope, the setback should be treated as Cut or Embankment. Any setback of less than 50 feet must be confirmed by appropriate geotechnical evaluation, including but not limited to



investigation of slope stability, evidence of rock or impermeable soil layers intersecting slope, seeps, or spring.

- (3) 100 feet from an unstable land mass. Horizontal setback distance from unstable land mass may only be reduced in accordance with recommendations provided in a Geotechnical Report prepared by a California civil engineer or professional geologist consistent with this Manual.

3. Fill

No dispersal of effluent shall be allowed within fill.

4. Trench Spacing

In sloping terrain, spacing between dispersal trench sidewalls shall be increased beyond minimum design requirements as follows:

- a. For dispersal trenches less than the standard 8-foot deep, minimum trench spacing (based on twice the trench sidewall) shall be increased by one (1) foot for each 5% incremental increase in ground slope above 20%; and
- b. Where geological conditions present special constraints, an increase in standard trench spacing requirements may be necessary in accordance with recommendations contained in the Geotechnical Report.

5. Geotechnical Report

“Geotechnical Report” means a written document used to communicate soil and geologic site conditions, interpretations, analysis and recommendations pertinent to the design, installation and operation of an OWTS in areas of steeply sloping terrain or near landscape features of geologic concern. A primary emphasis of the Geotechnical Report is the evaluation of potential slope stability issues that may be affected by or result in impacts to the operation of the proposed OWTS. An additional purpose of a Geotechnical Report may be to provide site-specific recommendations regarding appropriate horizontal setbacks from cuts, steep slopes and unstable land masses.

Where slopes in excess of twenty percent (20%) are proposed for use, substantiating detailed geotechnical data shall be provided to demonstrate that



wastewater surfacing and/or slope instability will not occur throughout the primary and designated reserve dispersal system areas or down-slope areas. Data shall include, but not be limited to:

- topography (by means of contours);
- subsurface lithological and structural data;
- all existing or proposed grading, including OWTS dispersal fields;
- accurate cross-sections showing all soil bedrock zones, etc.;
- seasonal groundwater elevation determination;
- surface drainage and soil erosion hazards; and
- any other appropriate factors.

For slopes of greater than thirty-five percent (35%), the Geotechnical Report shall include static and seismic analyses with safety factors of 1.5 and 1.2+, respectively, using residual strengths under saturated conditions.

As applicable, the Geotechnical Report shall present recommendations addressing horizontal setbacks to geologic/landscape features of concern, trench spacing, drainage and erosion control, and other pertinent design or construction issues.

Environmental Health staff may rely upon a third-party consultant to assist in the review of a Geotechnical Report. Costs for retaining a third-party consultant would be the responsibility of the project applicant.

E. CUMULATIVE IMPACT ASSESSMENT

For certain projects, typically non-residential and large flow OWTS, the completion of additional technical studies, termed “cumulative impact assessment”, may be required. This is to address the cumulative impact issues (mainly groundwater mounding and nitrogen loading) from OWTS that can result from such factors as the constituent levels in the wastewater (e.g., nitrogen content), the volume of wastewater flow, the density of OWTS discharges in a given area, and/or the sensitivity and beneficial uses of water resources in a particular location (e.g., proximity to impaired water bodies or vernal pools). These issues are not necessarily addressed by conformance with standard OWTS siting and design criteria.

Cumulative impact assessment is mandatory for any OWTS with projected wastewater flows of 2,500 gpd or more.

Cumulative impact assessment is not required for normal residential OWTS, regardless



of the type of system (conventional or alternative), except where the design flow exceeds 1,000 gpd (more than 6 bedrooms) or as may otherwise be determined by Environmental Health staff for certain situations or geographical areas of the county (e.g., Impaired Areas).

Cases where cumulative impact assessments shall be required are listed in Table 1 below.

Additionally, Environmental Health staff reserves the right to require the completion of a cumulative impact assessment in any case where, special circumstances related to the size, type, or location of the OWTS warrant such analysis.

Requirements and guidelines pertaining to cumulative impact assessments are detailed in Attachment A of this Section.



**Table 1
Projects Requiring Cumulative Impact Assessment***

Type of Project	Geographic Location	Lot Size (acres)	Design Wastewater Flow (gpd)	Groundwater Mounding Analysis	Nitrate Loading Analysis
Residence, including 2 nd dwelling unit	Countywide	-	< 1,000 (<7 bedrooms)	No	No
	Impaired Areas	TBD - Per TMDL/Advanced Protection Mgt Criteria			
Residence, including 2 nd dwelling unit	Countywide	< 1	1,000 + (7+ bedrooms)	No	Yes
	Impaired Areas	TBD - Per TMDL/Advanced Protection Mgt Criteria			
Multiunit and Non-residential	Countywide	< 1	1,000 +	No	Yes
		-	1,500+	Yes	No
		-	2,500+	Yes	Yes
	Impaired Areas	TBD - Per TMDL/Advanced Protection Mgt Criteria			
Subdivisions	Countywide	2.5+	-	No	No
		<2.5	-	No	Yes
	Impaired Areas	TBD - Per TMDL/Advanced Protection Mgt Criteria			
Any OWTS <200 feet from a vernal pool	Countywide	-	-	Yes**	Yes**

*Note: Environmental Health may also require cumulative impact assessment based on project or site specific conditions.

** The hydrological and water quality analysis requirements may be modified depending on site specific conditions and the extent to which the OWTS discharge contributes flow to catchment area supporting the vernal pool.



ATTACHMENT A GUIDELINES FOR CUMULATIVE IMPACT ASSESSMENT

- A. **GENERAL PROVISIONS.** San Mateo County Ordinance Code, Section 4.84.180 authorizes Environmental Health to require the completion of additional technical studies (“cumulative impact assessment”) for OWTS proposals in situations where cumulative impacts on groundwater and/or watershed conditions are of potential concern. Cumulative impacts from OWTS may occur due to such factors as the constituent levels in the wastewater (e.g., nitrogen content), the volume of wastewater flow, the density of OWTS discharges in a given area, and/or the sensitivity and beneficial uses of water resources.

Cumulative impact assessments to address potential concerns shall be conducted in accordance with the procedures and criteria outlined in this Manual. The results of the assessment shall be submitted for review by Environmental Health staff and may be the basis for denial, modification or imposition of specific conditions for the OWTS proposal, in addition to other siting and design criteria.

The findings from cumulative impact evaluations may also be used for the County designation of certain geographical areas as “Impaired Areas”, under the provisions of San Mateo County Ordinance, Section 4.84.170. This may result in the establishment of additional protections related to OWTS siting, design, installation, monitoring and reporting in such areas.

- B. **CUMULATIVE IMPACT ISSUES.** The primary issues to be addressed in cumulative impact assessments will normally include the following:

1. **Groundwater Mounding.** A rise in the water table, referred to as "groundwater mounding", may occur beneath or down-gradient of OWTS as a result of the concentrated or high volume of hydraulic loading from one or more systems in a limited area; and
2. **Groundwater Nitrate Loading.** Discharges from OWTS contain high concentrations of nitrogen that may contribute to rises in the nitrate level of local and regional aquifers.

For individual cases, Environmental Health staff may identify and require analysis of cumulative impact issues other than those listed above which, could pose potential water quality, public health, or safety risks.



C. **QUALIFICATIONS.** Required cumulative impact assessments shall be performed by or under the supervision of one of the following licensed professionals:

1. California Civil Engineer; or
2. California Professional Geologist

Additionally, the licensed professional assuming responsibility for the cumulative impact assessment should have training and experience in the fields of water quality and hydrology.

D. **CASES REQUIRING CUMULATIVE IMPACT ASSESSMENT.** Cases where cumulative impact assessments shall be required are listed in Table 1 below. Additionally, Environmental Health staff reserves the right to require the completion of a cumulative impact assessment in any case where special circumstances related to the size, type, or location of the OWTS warrants such analysis.



**Table 1
Projects Requiring Cumulative Impact Assessment***

Type of Project	Geographic Location	Lot Size (acres)	Design Wastewater Flow (gpd)	Groundwater Mounding Analysis	Nitrate Loading Analysis
Residence, including 2 nd dwelling unit	Countywide	-	< 1,000 (<7 bedrooms)	No	No
	Impaired Areas	TBD - Per TMDL/Advanced Protection Mgt Criteria			
Residence, including 2 nd dwelling unit	Countywide	< 1	1,000 + (7+ bedrooms)	No	Yes
	Impaired Areas	TBD - Per TMDL/Advanced Protection Mgt Criteria			
Multiunit and Non-residential	Countywide	< 1	1,000 +	No	Yes
		-	1,500+	Yes	No
		-	2,500+	Yes	Yes
	Impaired Areas	TBD - Per TMDL/Advanced Protection Mgt Criteria			
Subdivisions	Countywide	2.5+	-	No	No
		<2.5	-	No	Yes
	Impaired Areas	TBD - Per TMDL/Advanced Protection Mgt Criteria			
Any OWTS <200 feet from a vernal pool	Countywide	-	-	Yes**	Yes**

*Note: Environmental Health may also require cumulative impact assessment based on project or site specific conditions.

** The hydrological and water quality analysis requirements may be modified depending on site specific conditions and the extent to which the OWTS discharge contributes flow to catchment area supporting the vernal pool.



E. METHODS.

1. Groundwater Mounding Analysis

- a. Analysis of groundwater mounding effects shall be conducted using accepted principles of groundwater hydraulics. The specific methodology shall be described and supported with accompanying literature references, as appropriate.
- b. Assumptions and data used for the groundwater mounding analysis shall be stated along with supporting information. A map of the project site showing the location and dimensions of the proposed system(s) and the location of other nearby OWTS, wells and relevant hydrogeological features (e.g., site topography, streams, drainage channels, subsurface drains, etc.) shall be provided.
- c. The wastewater flow used for groundwater mounding analyses shall be the design sewage flow, unless supported adequately by other documentation or rationale.
- d. Groundwater mounding analyses shall be used to predict the highest rise of the water table and shall account for background groundwater conditions during the wet weather season.
- e. All relevant calculations necessary for reviewing the groundwater mounding analysis shall accompany the submittal.
- f. Any measures proposed to mitigate or reduce the groundwater mounding effects shall be presented and described as to their documented effectiveness elsewhere, special maintenance or monitoring requirements or other relevant factors.
- g. For OWTS located <200 feet from and within the catchment area of a vernal pool, an annual water balance analysis will also ordinarily be required to assess the extent of potential OWTS impacts on vernal pool hydrology.

2. Nitrate Loading

- a. Analysis of nitrate loading effects shall, at a minimum, be based upon construction of an annual chemical-water mass balance. The specific methodology shall be described and supported with accompanied literature references as appropriate.
- b. Assumptions and data for the mass balance analysis shall be stated,



along with supporting information. Such supporting information should include, at a minimum:

- (1) climatic data (e.g., precipitation, evapotranspiration rates);
 - (2) groundwater occurrence, depth and flow direction(s);
 - (3) background groundwater quality data, if available;
 - (4) soil conditions and runoff factors;
 - (5) wastewater characteristics (i.e., flow and nitrogen content); and,
 - (6) other significant nitrogen sources in the impact area (e.g., livestock, other waste discharges, etc.)
- c. A map of the project siting showing the location and dimensions of the proposed system(s) and the location of other nearby OWTS, wells and relevant hydrogeological features (e.g., site topography, streams, drainage channels, subsurface drains, etc.) shall be provided.
- d. The wastewater flow (average) used for nitrate loading analyses shall be as follows, unless adequately supported by other documentation or rationale:
- (1) For individual residential systems: 75 gpd/bedroom;
 - (2) For multi-family residential systems and other non-residential systems: average monthly wastewater flow for the proposed OWTS;
- e. Minimum values used for the total nitrogen concentration of septic tank effluent shall be as follows, unless supported adequately by other documentation or rationale:
- (1) Residential wastewater: 50 mg/l
 - (2) Non-residential wastewater: as determined from sampling of comparable system(s) or from literature values.
- Environmental Health staff may require the use of more conservative values than cited above if the values are judged (by EH) not likely to be representative of the proposed system(s).
- f. All relevant calculations necessary for reviewing the nitrate loading analysis shall accompany the submittal.
- g. Any measures proposed to mitigate or reduce the nitrate loading effects shall be presented and described as to their documented effectiveness elsewhere, special maintenance or monitoring requirements or other relevant factors.

F. EVALUATION CRITERIA

1. Groundwater Mounding. The maximum acceptable rise of the water table for short periods of time (e.g., one to two weeks) during the wet weather season, as estimated from groundwater mounding analyses, shall be as follows:



- a. General Requirement for all OWTS. Groundwater mounding shall not result in more than a 50-percent reduction in the required minimum depth to seasonally high groundwater per the County Ordinance Sections 4.84.120 and 4.84.165, as applicable, for the type of OWTS and site conditions. For example, where a 5-foot vertical separation to the native groundwater level is required, a short-term “mounding” rise of the water table to within 2.5 feet of trench bottom would be acceptable during peak wet weather conditions. Where a 3-foot vertical separation is required, a short-term rise to within 1.5 feet of trench bottom would be acceptable.
- b. Requirement for Large Systems. Notwithstanding (a) above, for all OWTS with design flows of 2,500 gpd or more (i.e., "large systems"), the groundwater mounding analysis shall demonstrate that the minimum required groundwater separation, per the County Ordinance Sections 4.84.120 and 4.84.165, will be maintained beneath the system during peak wet weather conditions.

Environmental Health staff may require, in any individual case or in specific geographical areas (e.g., designated impaired areas), a minimum of 2 feet of groundwater clearance (“mounded” conditions) where deemed necessary for protection of public health, or based upon specific requirements or recommendations of the applicable California Regional Water Quality Control Board.

Criteria for assessing hydrological impacts to vernal pools will be considered on a case-by-case basis. Environmental Health staff may rely upon Regional Water Quality Control Board staff or a third-party consultant to assist in the review. Costs for retaining a third-party consultant would be the responsibility of the project applicant.

2. Nitrate Loading. Minimum criteria for evaluating the cumulative nitrate loading from proposed OWTS shall be as follows:
 - a. For Areas Served By Individual Water Wells.
 - (1) Existing Lots of Record: New OWTS on existing lots of record shall not cause the groundwater nitrate-nitrogen concentration to exceed 7.5 mg-N/L at the nearest existing or potential point of groundwater withdrawal (e.g., water well location);
and



- (2) New Subdivisions: The total loading of nitrate from new subdivisions shall not result in an average groundwater nitrate-nitrogen concentration over the geographical extent of the subdivision that exceeds 7.5 mg-N/L.
- b. For Areas Not Served by Individual Water Wells.
 - (1) Existing Lots of Record: OWTS installed on existing lots of record shall not cause the groundwater nitrate-nitrogen concentration to exceed 10 mg-N/L at the nearest existing or potential point of groundwater withdrawal (e.g., water well location).
and
 - (2) New Subdivisions. The total loading of nitrate from new subdivisions shall not result in an average groundwater nitrate-nitrogen concentration over the geographical extent of the subdivision that exceeds 10 mg-N/L.

Environmental Health staff may require, in any individual case or specific geographical areas (e.g., designated impaired areas), more stringent nitrate-nitrogen compliance criteria where deemed necessary for protection of public health, or based upon specific requirements or recommendations of the applicable California Regional Water Quality Control Board.

Criteria for assessing nitrate or other water quality impacts to vernal pools will be considered on a case-by-case basis. Environmental Health staff may rely upon Regional Water Quality Control Board staff or a third-party consultant to assist in the review. Costs for retaining a third-party consultant would be the responsibility of the project applicant.



FORMS AND FIGURES



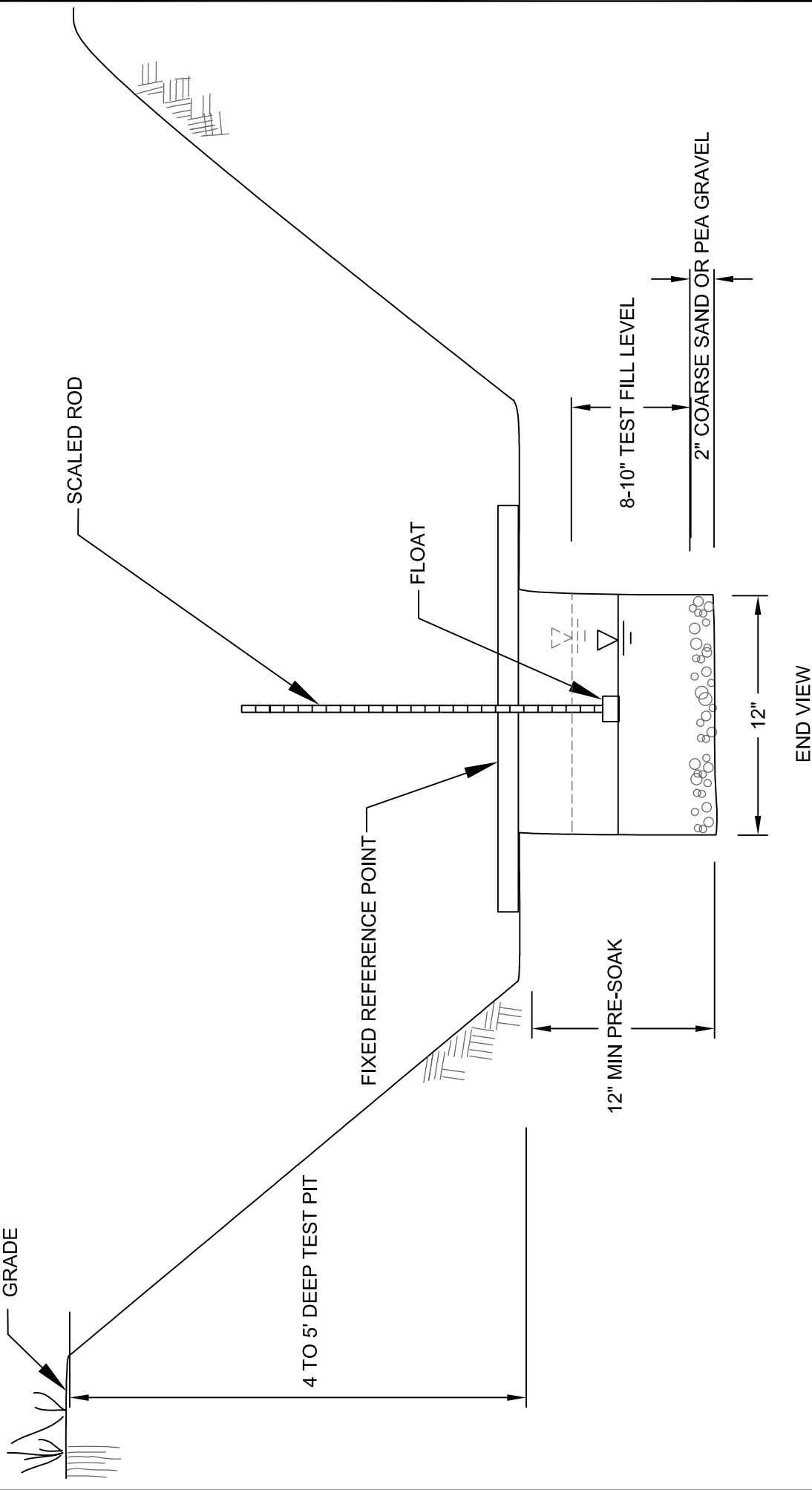
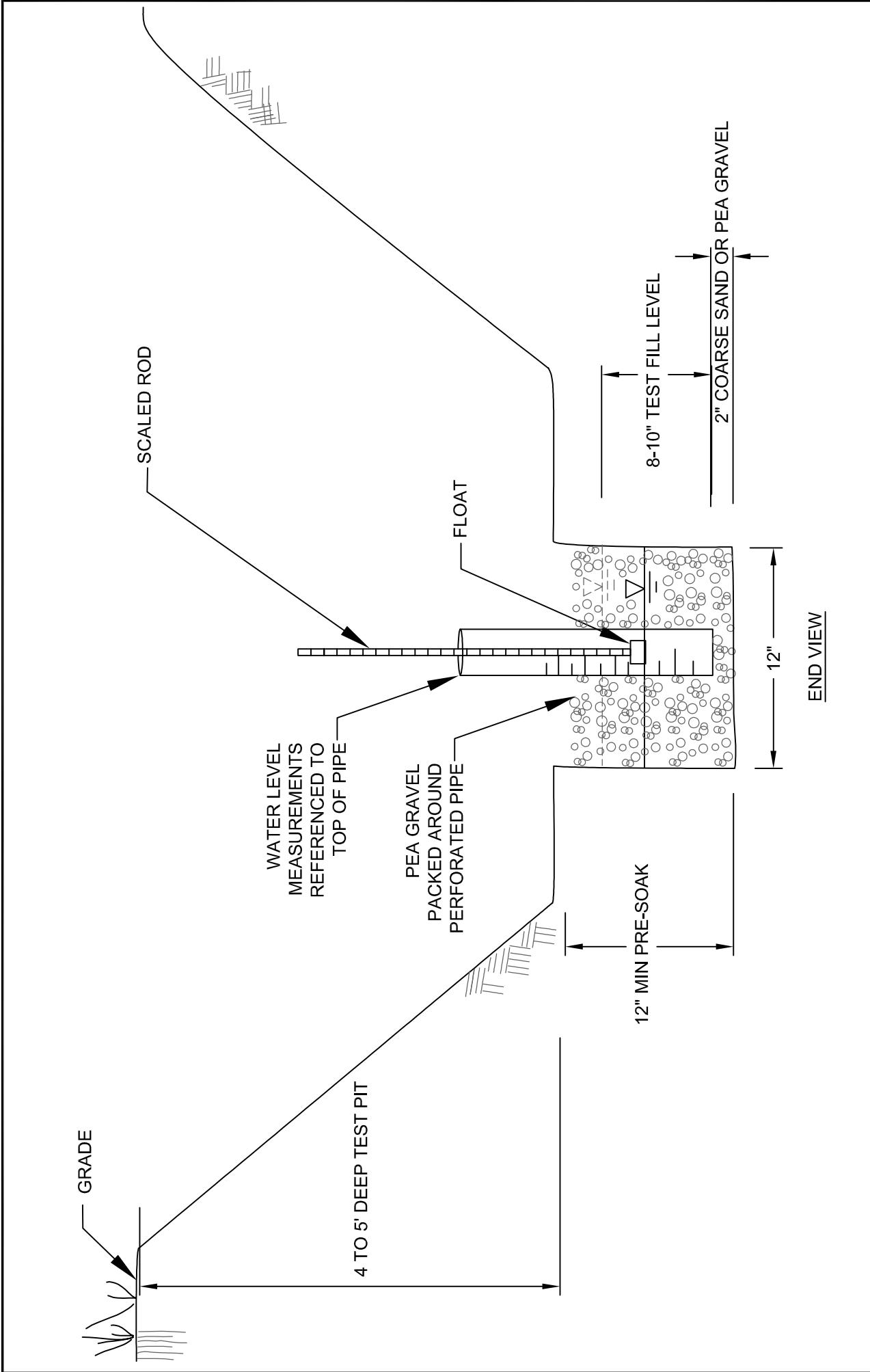

FIGURE
2-1

DIAGRAM OF A PERCOLATION TEST



**DIAGRAM OF A
GRAVEL-PACKED
PERCOLATION TEST**

**FIGURE
2-2**



SAN MATEO COUNTY
ENVIRONMENTAL HEALTH SERVICES DIVISION

MEASUREMENTS

½ HOUR INTERVALS	READINGS	HOLE #1	HOLE #2	HOLE #3	HOLE #4	HOLE #5	HOLE #6
1	FINISH						
	START						
	DIFF.						
2	FINISH						
	START						
	DIFF.						
3	FINISH						
	START						
	DIFF.						
4	FINISH						
	START						
	DIFF.						
5	FINISH						
	START						
	DIFF.						
6	FINISH						
	START						
	DIFF.						
7	FINISH						
	START						
	DIFF.						
8	FINISH						
	START						
	DIFF.						

SITE INFORMATION

Site Address: _____ APN: _____

Size Of Parcel: _____ Subdivision Number: _____

Soil Log: _____ Water Source: _____

Depth To Ground Water: _____

Wet Weather Testing Required? YES NO

Tested By: _____ Tester #: _____

Observed in Field By: _____ Date: _____

SECTION 3 DESIGN AND CONSTRUCTION REQUIREMENTS FOR CONVENTIONAL OWTS

CONTENTS

- A. DESCRIPTION
- B. SITING CRITERIA
- C. WASTEWATER FLOWS FOR OWTS DESIGN
- D. SEPTIC TANK REQUIREMENTS
- E. DISPERSAL SYSTEM REQUIREMENTS

FORMS AND FIGURES



SECTION 3

DESIGN AND CONSTRUCTION REQUIREMENTS FOR CONVENTIONAL OWTS

A. DESCRIPTION

Per San Mateo County OWTS Ordinance, a “Conventional OWTS” means a type of OWTS consisting of a septic tank for primary treatment of sewage followed by gravity flow to a system of drainfield trenches for subsurface dispersal of effluent into the soil.

B. SITING CRITERIA

The following minimum siting criteria must be met for approval of any conventional OWTS.

1. Accessible. OWTS must be located to be easily accessible for maintenance and repairs.
2. Within Property Boundaries. The septic tank, dispersal system, and other components of the OWTS shall be located within the boundaries of the parcel upon which the structure requiring the system is built.
3. Soil Depth. Soil of an accepted quality to receive effluent from the dispersal system shall extend a minimum depth of three (3) feet below the bottom of the dispersal trenches.
4. Soil Fill. No dispersal of effluent shall be allowed within soil fill.
5. Soil Cover. All dispersal systems shall have at least twelve (12) inches of soil cover.
6. Underground Utilities. Underground utility lines, conduits or trenches, including irrigation lines, shall not be installed across dispersal systems, nor shall they be located near dispersal systems so as to pose a potential preferential pathway for effluent.
7. Vertical Groundwater Separation. Minimum required vertical separation distance between trench bottom and groundwater shall be 5 feet.
8. Areas of Flooding. OWTS shall not be located in low-lying areas subject to annual flooding on the basis of flood mapping or historical evidence acceptable to Environmental Health staff.
9. Compacted Areas. OWTS shall not be located in areas subject to vehicular traffic or other areas subject to significant compaction, including areas of concentrated livestock use.
10. Ground Slope. Maximum ground slope in the conventional dispersal system area shall not exceed thirty-five (35) percent. Additionally, for any site where the



ground slope exceeds twenty percent, approval shall be dependent upon completion of a geotechnical report as provided in the County Ordinance and Section 2 of this Manual.

11. Soil Percolation Rate. The average soil percolation rate in the proposed conventional dispersal field area shall not be faster than 12 inches per hour (5 minutes per inch) nor slower than 1.00 inches per hour (60 minutes per inch), determined in accordance with procedures prescribed in Section 2 of this Manual (soil percolation rates of less than 1-inch per hour require pressure dosing as described in Section 4 of this Manual).
12. Horizontal Setbacks. Minimum horizontal setback distances from various site features to OWTS components shall be as listed in Table 3-1 below:



Table 3-1. Minimum Horizontal Setback Distances

Site Feature	Minimum Setback Distance (feet)	
	To Septic Tank	To Dispersal Field
Building or foundation	5	10
Septic tank	N/A	10
Property line		
-From properties served by wells or springs	50	50
-From properties served by approved public water supply	10	10
Swimming pool or spa	25	25
Road easement, pavement or driveway	5	5
Watercourses		
-General (from top bank)	100	100
-Between 1200 to 2500 feet from a public or State small water system intake	100	200 ¹
-Within 1200 feet downstream from a public or State Small water system intake	100	400 ¹
All wells and domestic/irrigation springs	100	100
Public and State small water system supply wells or springs	150	150
Reservoirs (from high water mark)		
-General	200	200
-Within 1200 feet from a public or State small water system intake	200	400
Groundwater interceptor trench or drain	5	25
Stormwater infiltration trench, gallery or well	25	25
Drainage ditch or swale (from edge of flow path)		
-General, lined or unlined	25	25
-Evidence of sustained wet conditions or ponding	25	50
Cuts or embankments (from top of cut)	10	4 x h ^{2,3}
Steep Slopes (lower in elevation than OWTS) ⁴		
-Height of steep slope less than 12 feet	10	25 ³
-Height of steep slope greater than 12 feet	10	50
Unstable land mass ⁵	100 ⁴	100 ⁴

¹ For areas tributary to and upstream of water supply intake; setback distance measure from high water mark. Exceptions may be allowed per SWRCB OWTS Policy, as follows:



- (a) for replacement OWTS, comply with the maximum extent practicable and incorporate supplemental treatment unless Environmental Health finds no impact or significant threat to water source;
- (b) for new OWTS on pre-existing lot of record (pre-May 13, 2013), comply to maximum extent practicable and incorporate supplemental treatment for pathogens per County Ordinance, Section 4.84.145 and prescribed by Environmental Health in this Manual.

² 'h' equals the height of cut or embankment, in feet. The required setback distance shall not be less than twenty five (25) feet nor more than fifty (50) feet.

³ Steep slope is considered to be land with a slope of greater than or equal to fifty percent (50%). Where there is clearly discernible embankment and/or break in slope, treat as Cut or Embankment. Setback of less than 50 feet must be confirmed by appropriate geotechnical evaluation, including but not limited to investigation of slope stability, evidence of rock or impermeable soil layers intersecting slope, seeps, or springs.

⁴ Setback distance may be reduced in accordance with recommendations provided in a geotechnical report prepared by a California civil engineer or professional geologist consistent with guidelines prescribed by Environmental Health in Section 2 of this Manual.

C. WASTEWATER FLOWS FOR OWTS DESIGN

1. Single Family Residences and Second Units. Wastewater flows used for design of OWTS for single family residences and second units are based on a factor of 150 gal/day per bedroom. The septic tank and dispersal systems for a primary residence and secondary dwelling unit shall be determined (as described in Section 3.D. and 3.E. below) based on total bedroom count where the primary residence and secondary dwelling unit share the same OWTS, and determined independently where the primary residence and secondary dwelling unit use separate OWTS.
2. Multiunit Residences and Non-residential Facilities. Wastewater flows used for the design of OWTS for multi-unit residences and non-residential projects shall be developed based on full consideration of projected activities, occupancy, and facilities. Guidelines provided in the 2002 US EPA Onsite Wastewater Treatment Systems Manual (Chapter 3) shall be used as the primary reference in estimating



design wastewater flows. For facilities not covered in the 2002 US EPA Onsite Wastewater Treatment Systems Manual, wastewater design flow shall be estimated based on either: (a) other appropriate literature references for the type of facility proposed; or (b) documented wastewater flow monitoring data for a comparable facility. Additionally, Environmental Health staff may consider case-by-case adjustment(s) of literature values based on more specific documented wastewater flow monitoring data. In all cases, the design proposal shall include sufficient technical information to support the proposed design flow estimate. Notwithstanding the above, minimum design flow for any OWTS shall not be less than 150 gpd.

3. **Flow Equalization.** Flow equalization is the process of controlling the rate of wastewater flow through an OWTS by providing surge capacity storage and timed-dosing of the incoming flow. Installed downstream from the septic tank, it allows peak surges in wastewater flow (e.g., from a weekend event) to be temporarily stored and metered into the treatment system and/or dispersal field at a relatively even (“average”) rate over an extended number of days (e.g., during the subsequent week). This generally aids OWTS performance.

Flow equalization may be used for non-residential and mixed use facilities that experience significant, regular and predictable fluctuations in wastewater flows. Examples of applicable facilities include, but are not limited to:

- Churches;
- Schools; and
- Special event venues.

Where flow equalization is proposed to be incorporated in an OWTS the following apply:

- the septic tank capacity shall be sized based on the peak daily flow for the facility;
- the design flow used for sizing supplemental treatment unit(s) and/or the dispersal system may be based on the equalized (“average”) flow rate rather than the peak daily flow rate for the facility;
- engineering calculations and specifications must be submitted substantiating the proposed design and operation of the flow equalization system; and
- an operating permit (per the County Ordinance Section 4.84.155 and this Manual) will be required.



D. SEPTIC TANK REQUIREMENTS

1. **Materials for Construction.** Reinforced concrete or other durable materials that are not subject to excessive corrosion or decay and which will produce a watertight tank shall be used. Interior surfaces of porous tanks require a coating, such as a water-based acrylic similar to Conseal CS-55 or a flexible polyurethane/polyuria elastomer similar to BASF's ElastoCast S55090R resin, or similar compound to minimize corrosion, typically meeting requirements of 40CFR261.4 for solid waste management. The coating shall extend from the top of the tank to six (6) inches below the water line.

Existing wooden septic tanks do not meet current septic code and must be replaced with appropriate septic tanks.

2. **Size of tank.** All septic tanks must have a minimum capacity of fifteen hundred (1,500) gallons or as specified below, whichever is greater.

- a. For single-family residences and second dwelling units, minimum septic tank capacity shall be based on bedroom count as follows:

- 1 - 4 bedrooms - 1,500 gallons
- 5 – 6 bedrooms - 2,000 gallons
- 7 – 8 bedrooms - 2,500 gallons
- 9 – 10 bedrooms - 3,000 gallons

- b. For multifamily and non-residential systems, minimum septic tank capacity shall be equal to at least two (2) times the peak daily wastewater flow for the facility served. Where a septic tank is employed in connection with a supplemental treatment system, the septic tank shall also meet minimum sizing requirements of the treatment system manufacturer, as applicable.

3. **Design.**

- a. Septic tanks for private residences shall be one (1) piece comprised of two (2) compartments with the first compartment containing two-thirds of the total tank volume.
- b. Septic tanks installed to serve other than individual residential structures shall meet the same requirements specified for private residences in (a) above. However, for larger flow OWTS exceptions will be permitted allowing the use of multiple tanks instead of a single (one-piece) tank.
- c. Each tank shall be structurally designed to withstand all anticipated loads, stress and weight. Tanks subjected to vehicular traffic shall be traffic-rated to State Department of Transportation Standard H20-44 truck loading standards.



Complete plans and design calculations shall be submitted for approval prior to installation.

- d. All septic tanks shall be approved by the International Association of Plumbing and Mechanical Officials (IAPMO) or stamped and certified by a California registered civil engineer as meeting the industry standards.
- e. The outlet of the septic tank shall be fitted with an effluent filter capable of screening solids in excess three-sixteenths (3/16) of an inch in diameter and conforming to NSF/ANSI Standard 46 or as otherwise approved by Environmental Health staff.
- f. Septic tank designs that differ from the above requirements may be considered by Environmental Health staff if supported by appropriate technical analysis demonstrating equal or better septic tank functionality and performance.

4. Location and Installation.

- a. The septic tank shall be located in a place accessible for vacuum pumping. Each compartment shall be provided with an access port extending at least to grade and covered with watertight, weight-bearing covers. Access openings shall be locked or otherwise secured to prevent unauthorized access.
- b. Where a setback variance is granted, a septic tank may be permitted closer than 5 feet, or under driveways provided it is traffic-rated and the septic tank is provided with a metal sewer access ring and cover over both compartments.
- c. No pumping of sewage from the house/building to the septic tank shall be permitted; gravity flow only shall be utilized.
- d. Tanks shall have a minimum of eight (8) inches of soil cover; however, as a minimum, tank access risers shall extend to grade.
- e. All connections from building to septic tank must conform to construction standards as required by the County or City building official, as applicable.
- f. Water-tightness Testing. All new septic tank installations and modifications to existing septic tanks shall undergo water-tightness testing as follows:
 - (1) New Tanks. For new tank installations, the testing shall be done with the risers in place and the inlet and outlet pipes plugged. The tank shall be filled with water to a level extending a minimum of two (2) inches into the risers, and monitored for a 1-hour period, with no measurable drop in the water level.



- (2) Existing Tanks. For existing tanks, the tank shall be filled with water to a level even with the invert of the outlet pipe, and monitored for a 1-hour period, with no measurable drop in water level. However, in cases where the groundwater level is known or estimated to rise above the level of the outlet pipe during any time of the year, the water-tightness test shall be conducted following the procedure for new tank installations (i.e., by filling the tank with water into the risers).

E. DISPERSAL SYSTEM REQUIREMENTS

1. Trench Specifications.

- a. Width. The width of the conventional dispersal system trench shall be a minimum of eighteen (18) inches and a maximum of twenty four (24) inches.
- b. Depth and cover. The depth of the standard conventional dispersal system trench shall be eight (8) feet deep with six (6) feet of properly graded clean $\frac{3}{4}$ - to $1\frac{1}{2}$ -inch rock fill beneath the distribution pipe (see Dispersal System Sizing – Residential) and extending at least two (2) inches above the top of the distribution pipe. The drain rock shall be covered with a layer of filter fabric and then with twelve (12) to eighteen (18) inches of uncompacted native soil. Trenches of greater than 8 feet depth may require a variance. No conventional dispersal system trench shall have less than 1 foot of rock beneath the distribution pipe.
- c. Trench Spacing.
- (1) The minimum distance between standard (8-foot deep) dispersal system trenches shall be fifteen (15) feet, measured horizontally from the edges of adjacent trenches.
 - (2) For trench designs less than 8-foot deep, the minimum horizontal spacing between adjacent trenches shall be equal to two (2) times the sidewall depth of the trench; but in no case less than 6 feet.
 - (3) For sloping terrain, minimum trench spacing in conditions (1) and (2) above shall be increased by one (1) foot for each 5% incremental increase in slope above 20%.
 - (4) Where geological conditions indicate, an increase in the above spacing requirements may be necessary.
 - (5) Designated replacement trenches must maintain the same spacing from other trenches, whether installed or simply designated for potential replacement value.
- d. Diversion Valve. The total dispersal system shall be divided into two (2) equal lengths preceded by a diversion valve or equivalent device of approved design to allow for alternate use of each half of the dispersal system.



- e. On Contour. Each half of the dispersal system shall, whenever possible, be located on one contour (one elevation).
- f. Piping. Three (3) inch minimum diameter solid pipe schedule 40 PVC or stronger shall be used between the septic tank and dispersal system and between units of dispersal system trenches.
- g. Minimum/Maximum Length. Minimum length for a trench shall be twenty five (25) feet. Maximum length shall be one hundred twenty five (125) feet for gravity flow systems.
- h. Materials. The standard trench shall have six (6) feet of properly graded clean rock fill of $\frac{3}{4}$ to $1\frac{1}{2}$ inch size below the standard perforated drain pipe and extending at least two (2) inches above the top of the perforated drain pipe. The rock fill shall be covered with a protective layer of filter fabric and then with twelve (12) to eighteen (18) inches of lightly compacted (e.g., approximately 85%) native topsoil. Potential alternate materials, along with complete specifications, may be proposed to Environmental Health for consideration. Use of such alternate materials may require a variance with applicable fee.

2. Dispersal System Sizing – Residential.

Dispersal system sizing for single-family residential systems considers a standard 8-ft deep trench with 6 feet of drain rock beneath the distribution piping. For shallower trenches the equivalent infiltrative area is calculated based on the side-wall area beneath the distribution pipe, not counting the base of trench. Main house residential installations and main house with secondary dwelling unit using the same OWTS shall be in accordance with the following:

- a. For stabilized percolation rates of at least two (2) inches per hour but less than twelve (12) inches per hour:
 - (1) Up to three bedrooms – two lines each of seventy (70) linear feet;
 - (2) Each additional bedroom – add twenty (20) linear feet to each line.
- b. For stabilized percolation rates between one (1) inch per hour and one and ninety-nine hundredths (1.99) inches per hour:
 - (1) Up to three bedrooms – two (2) lines each of one hundred twenty five (125) feet;
 - (2) Each additional bedroom – add forty (40) feet to each line.



- c. For stabilized percolation rates between three-fourths (0.75) and ninety-nine hundredths (0.99) inches per hour:
 - (1) Up to three bedrooms – two (2) lines each of one hundred eighty (180) feet;
 - (2) Each additional bedroom – add sixty (60) feet to each line.
- d. Dispersal systems located in soils demonstrating percolation rates of between three-fourths (0.75) and ninety-nine hundredths (0.99) inches per hour shall utilize pressure dosing to distribute wastewater uniformly. See Section 4 of this Manual (Alternative OWTS) for additional requirements applicable to pressure distribution trench systems.
- e. No individual onsite wastewater treatment and disposal system which requires percolation of wastewater into the ground shall be approved where the stabilized percolation rate is less than three-fourths (0.75) inch per hour or more than twelve (12) inches per hour.
- f. Dispersal systems of lesser effective depths (<6 feet beneath distribution pipe) but equivalent effective sidewall infiltrative area may be permitted subject to the approval of Environmental Health.
- g. 100% reserve area equivalent to and separate from the proposed primary dispersal system area is required.

3. Dispersal System Sizing – Second Dwelling Units (separate OWTS).

Dispersal system sizing for second dwelling units considers a standard 8-ft deep trench with 6 feet of drain rock beneath the distribution piping. For shallower trenches the equivalent infiltrative area is calculated based on the side-wall area beneath the distribution pipe, not counting the base of trench. Secondary dwelling units of one (1) or two (2) bedrooms using a stand-alone OWTS (not connected to the main house OWTS) shall be in accordance with the following:

- a. For stabilized percolation rates of two (2) inches per hour but less than twelve (12) inches per hour:
 - (1) One bedroom (or studio) – two lines each of thirty (30) linear feet;
 - (2) Two bedrooms – two lines each of fifty (50) linear feet.
- b. For stabilized percolation rates between one (1) inch per hour and one and ninety-nine hundredths (1.99) inches per hour:
 - (1) One bedroom (or studio) – two lines each of forty five (45) linear feet;



- (2) Two bedrooms – two lines each of eighty five (85) linear feet.
 - c. For stabilized percolation rates between three-fourths (0.75) and ninety-nine hundredths (0.99) inches per hour:
 - (1) One bedroom (or studio) – two lines each of sixty (60) linear feet;
 - (2) Two bedrooms – two lines each of one hundred twenty (120) linear feet.
 - d. The requirements in Section 3.E.2.d. through g. above apply to second dwelling unit installations.
4. **Dispersal System Sizing – Multifamily and Non-Residential.** Dispersal system sizing for multi-family and non-residential installations shall be in accordance with the following:
- a. Design Flow. Design wastewater flow used for determining the required square footage and length of dispersal system trench shall be determined in accordance with the criteria in Paragraph C – Wastewater Flows for OWTS Design above; and
 - b. Wastewater Application Rates. The wastewater application rate(s) used for determining the required infiltrative surface area and overall trench length shall be based upon representative soil percolation test results for the soil zone corresponding with trench bottom depth, and the criteria in Table 3-2.
 - c. General Dispersal System Requirements. The requirements in Section 3.E.2.d. through g. above apply to multifamily and non-residential installations.

Table 3-2
Wastewater Application Rates for Drain Field Trench Sizing¹
For Multifamily and Non-residential Installations

Percolation Rate		Wastewater Application Rate (gpd/ft ²)
Inches /Hr	Min per Inch	
> 12	< 5	Not Permitted
12.0	5	1.20
6.0	10	0.80
2.5	24	0.60



2.0	30	0.56
1.5	40	0.49
1	60	0.35
0.75	80	0.20
< 0.75	> 80	Not Permitted

¹ Interpolate between reference values for other percolation rates; see attached table for expanded listing of interpolated values.

d. Effective Infiltrative Area.

(1) Standard Requirement. For trench sizing, the “effective infiltrative area” shall be limited to four (4) square feet per lineal foot of trench length, counting only trench sidewall area below the invert of the perforated distribution pipe.

(2) Deep Trench Exception. Under certain (favorable) soil and site conditions where deeper dispersal trench (e.g., up to 8-feet deep) construction is acceptable; the effective infiltrative surface may be increased up to a maximum of eight (8) square feet per lineal foot. This exception is limited to OWTS dispersal sites where: (a) ground slope is <20%; and (b) soil percolation rate is in the range of 2 inches per hour (30 mpi) to 12 inches per hour (5 mpi).

e. Trench Length Calculation. Required trench length for 100% capacity dispersal field shall be calculated as follows:

$$\text{Trench Length, } L = Q / (R * A)$$

Where:

Q = Design (peak) wastewater flow, gpd

R = Wastewater application rate, in gpd/ft²

A = Total infiltrative area per lineal foot of trench, in ft² (4ft² standard)

f. Dual System Requirement. Total dispersal trench capacity shall be provided for (2) 100% fields (primary and secondary) each sized per (d) above. Both primary and secondary fields shall be installed, and shall be equipped with an approved (manual) diversion device to allow alternating use of the two fields, typically switching between fields every 6 to 12 months.

5. Trench Construction.

a. Both the perforated drain tile pipe and the trench bottom shall be level.



- b. Perforated pipe shall be a minimum of 2,000 lb. Standard crush weight ASTM F810-8149232 or greater and shall be capped at the ends.
- c. Soil of an accepted quality to receive effluent from the drain field shall extend a minimum of three (3) feet below the dispersal system.
- d. Capped observation standpipes shall be installed at the end of each dispersal system trench, and extend from the bottom of the trench to ground level. The standpipe shall not be connected to the drain line.
- e. No dispersal of effluent shall be allowed within soil fill material.
- f. The dispersal system shall not be located under any paving or in an area subject to vehicular traffic.
- g. Underground utility lines, conduits or trenches, including irrigation lines, shall not be installed in or across dispersal systems, nor shall they be located near dispersal systems so as to pose a potential pathway for effluent.
- h. Trenches shall be constructed when the soil is dry. If moisture still remains in portions of the soil resulting in a smearing (sealing) effect on the sidewalls by the excavating equipment, the sidewalls shall be adequately scarified to restore the soil to its original drainage capacity.
- i. Trenches shall not be left without adequate cover overnight if rock fill is not added the same day as excavation.
- j. Appropriate erosion control measures must be employed during any excavation or earth movement activities.
- k. Environmental Health staff shall be notified for inspection at least twenty four (24) hours prior to the excavation of trenches.

6. **Construction Inspection.** At a minimum, inspection of conventional OWTS installation should include the items listed below. Joint inspection by the designer, contractor, and Environmental Health may be required.

- a. Pre-construction inspection where the construction staking or marking of the various system components is provided and construction procedures discussed.



- b. Open trench inspection of dispersal trench dimensions and conditions.
- c. Drain rock and perforated pipe materials and placement.
- d. Location and proper installation of diversion valve(s).
- e. Location, size, materials, and water tightness testing of septic tank.

- f. Final inspection to verify that all construction elements are in conformance with the approved plans and specifications, and final trench backfill/cover and erosion control has been completed.

Any field changes to the approved OWTS design shall be documented in a set of “as-built” drawings supplied to Environmental Health by the system designer, which shall be required before final written notice of installation approval is issued by Environmental Health.



FORMS AND FIGURES



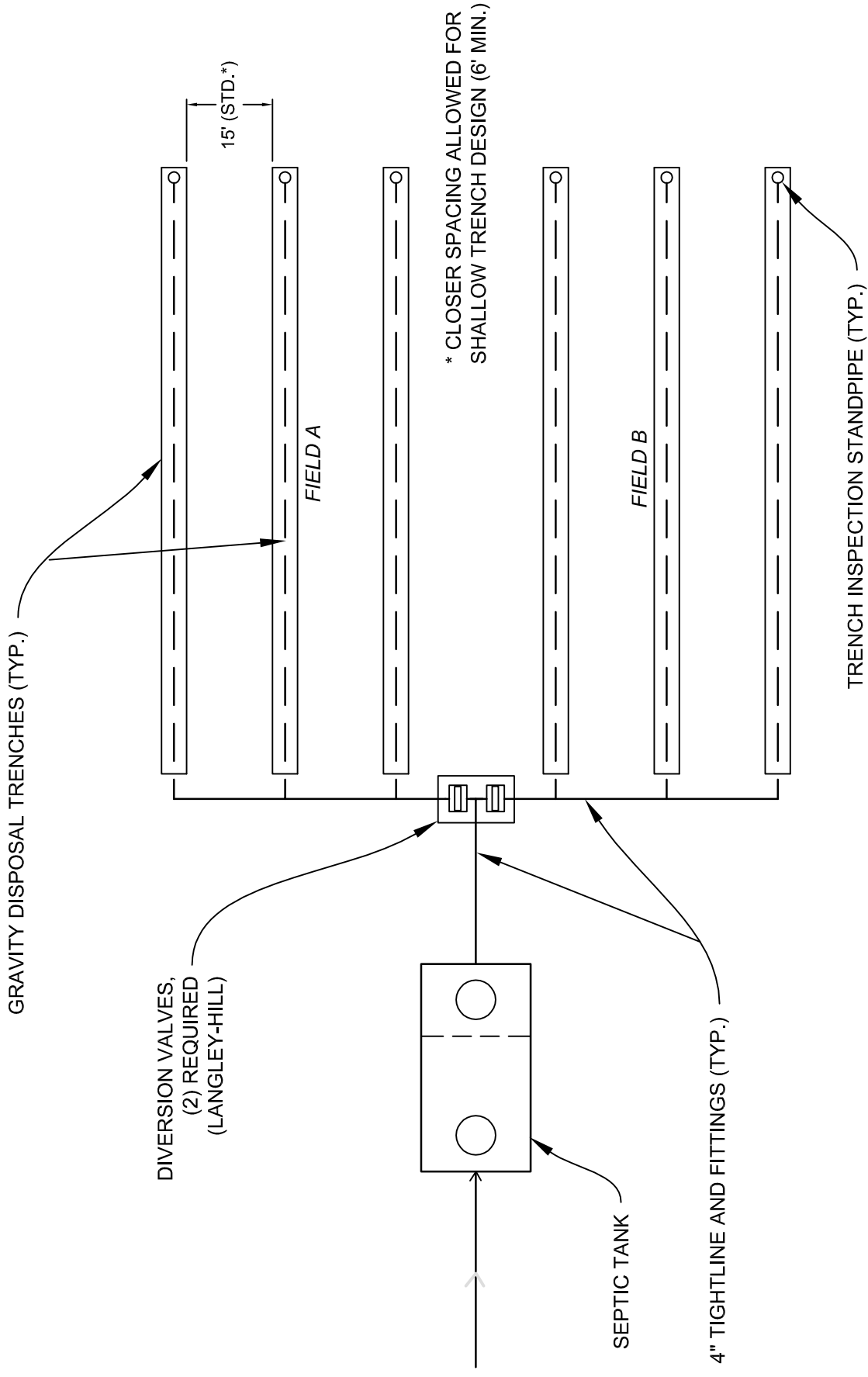

NOTE: ADDITIONAL 100% RESERVE AREA TO BE PROVIDED (NOT SHOWN)

FIGURE 3-1

CONVENTIONAL GRAVITY TANK AND DRAINFIELD SCHEMATIC

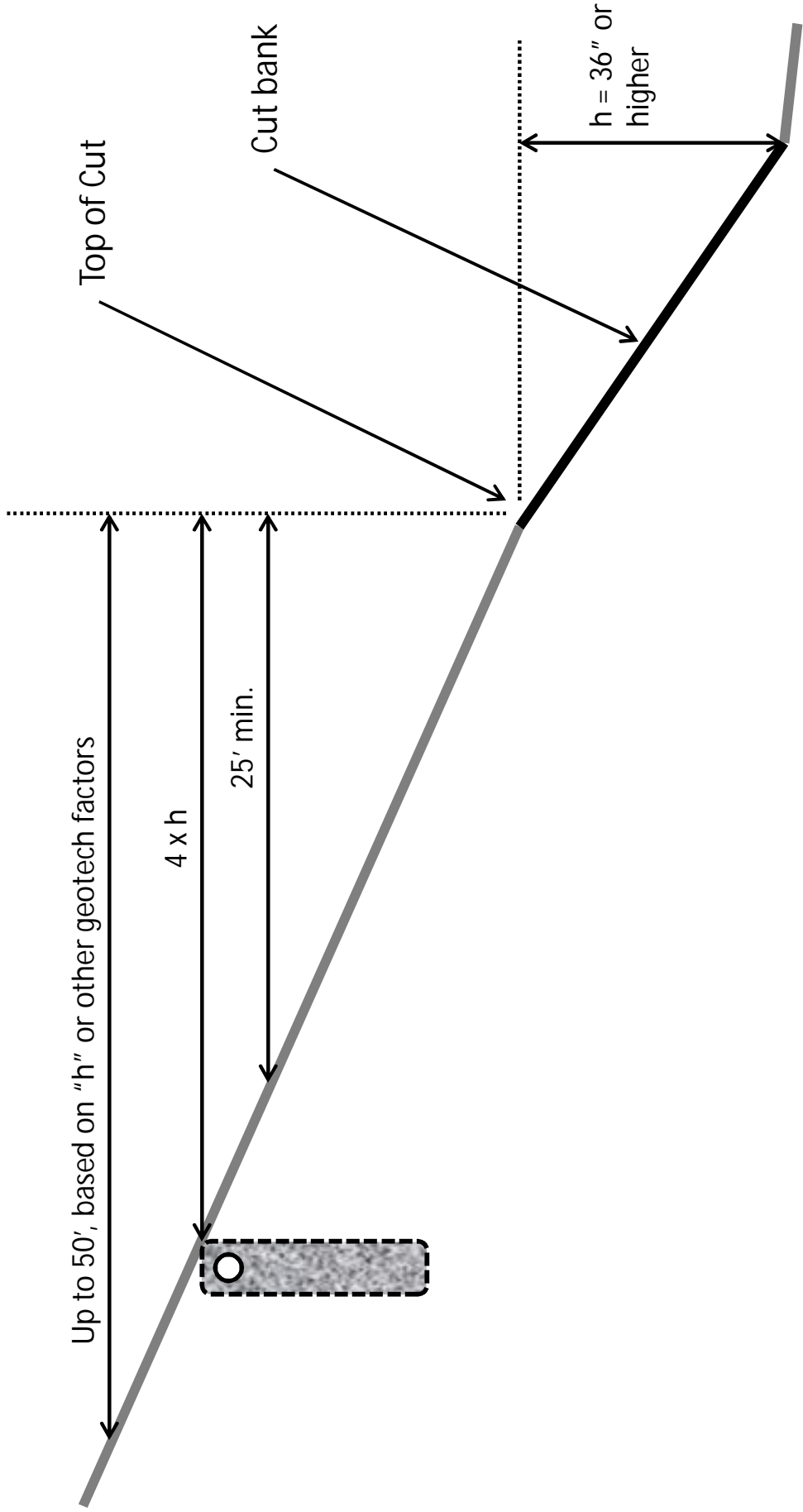

Setback to Cut or Embankment

FIGURE
3-2

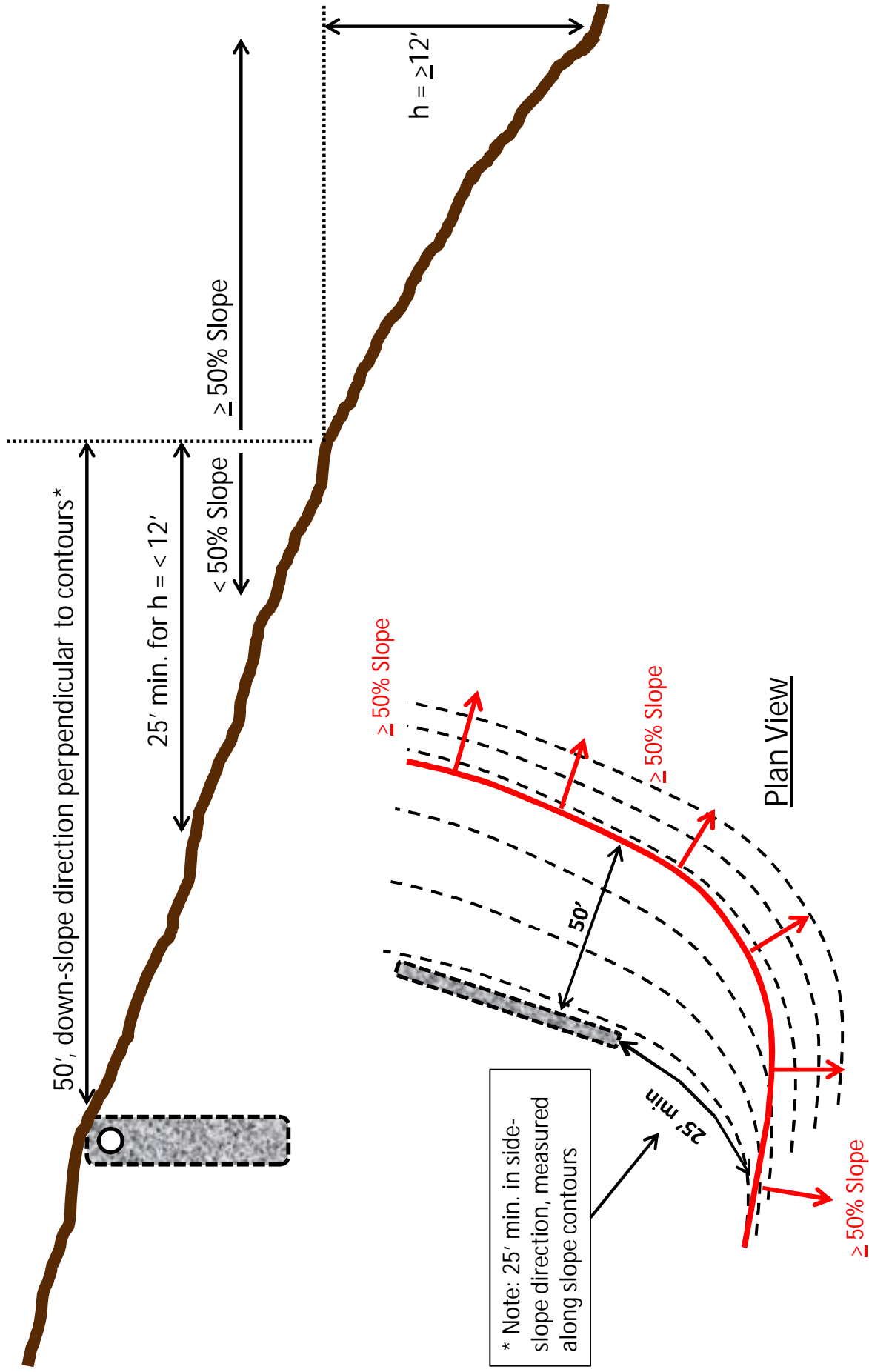

Setback to Slope of 50% or Greater

FIGURE 3-3

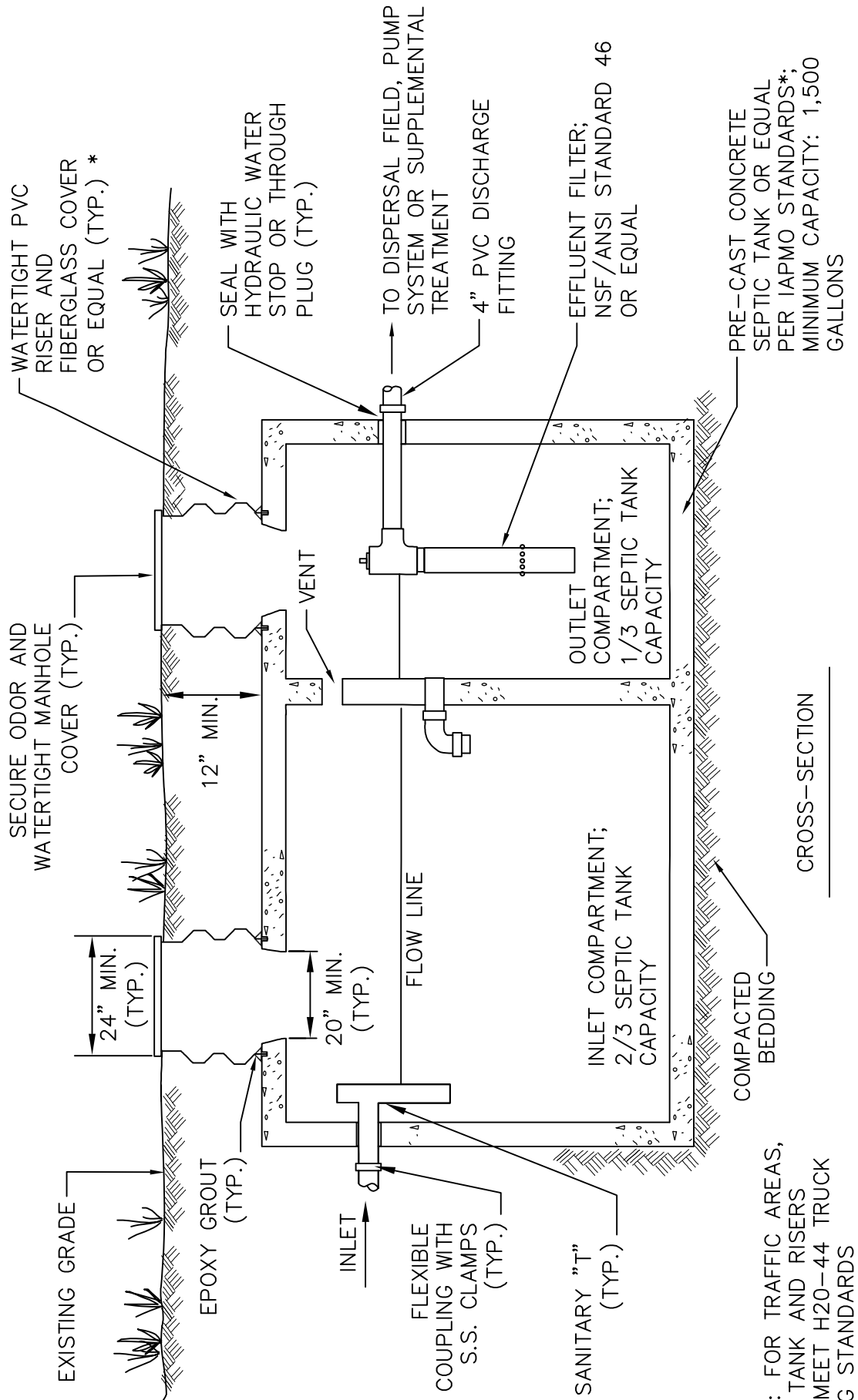

* NOTE: FOR TRAFFIC AREAS, SEPTIC TANK AND RISERS SHALL MEET H20-44 TRUCK LOADING STANDARDS

FIGURE 3-4

TYPICAL SEPTIC TANK

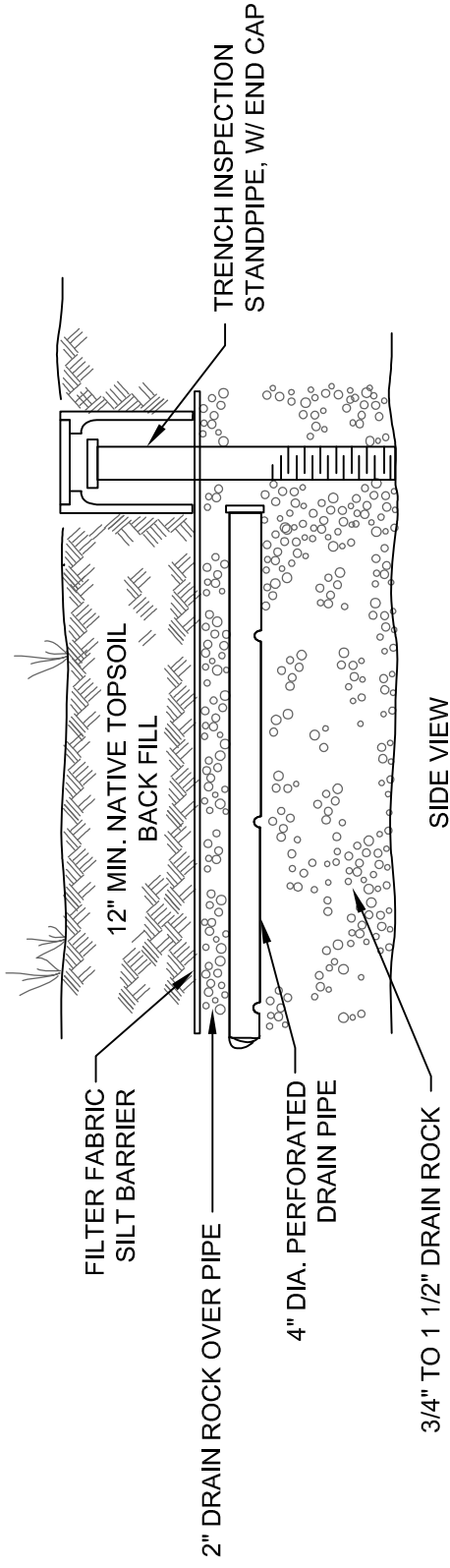

NOTES:

1. FOR RESIDENTIAL OWTS, DRAIN FIELDS OF LESSER DEPTHS (<6 FT. SIDEWALL DEPTH) BUT EQUIVALENT OVERALL SIDEWALL AREA MAY BE PERMITTED SUBJECT TO THE APPROVAL OF ENVIRONMENTAL HEALTH.
2. FOR MULTIFAMILY AND NON-RESIDENTIAL OWTS:
 - THE "EFFECTIVE INFILTRATIVE AREA" SHALL BE LIMITED TO FOUR (4) SQUARE FEET PER LINEAL FOOT OF TRENCH LENGTH, COUNTING ONLY TRENCH SIDEWALL AREA BELOW THE INVERT OF THE PIPE;
 - UNDER CERTAIN (FAVORABLE) SOIL AND SITE CONDITIONS, THE EFFECTIVE INFILTRATIVE SURFACE MAY BE INCREASED TO UP TO A MAXIMUM OF EIGHT (8) SQUARE FEET PER LINEAL FOOT.

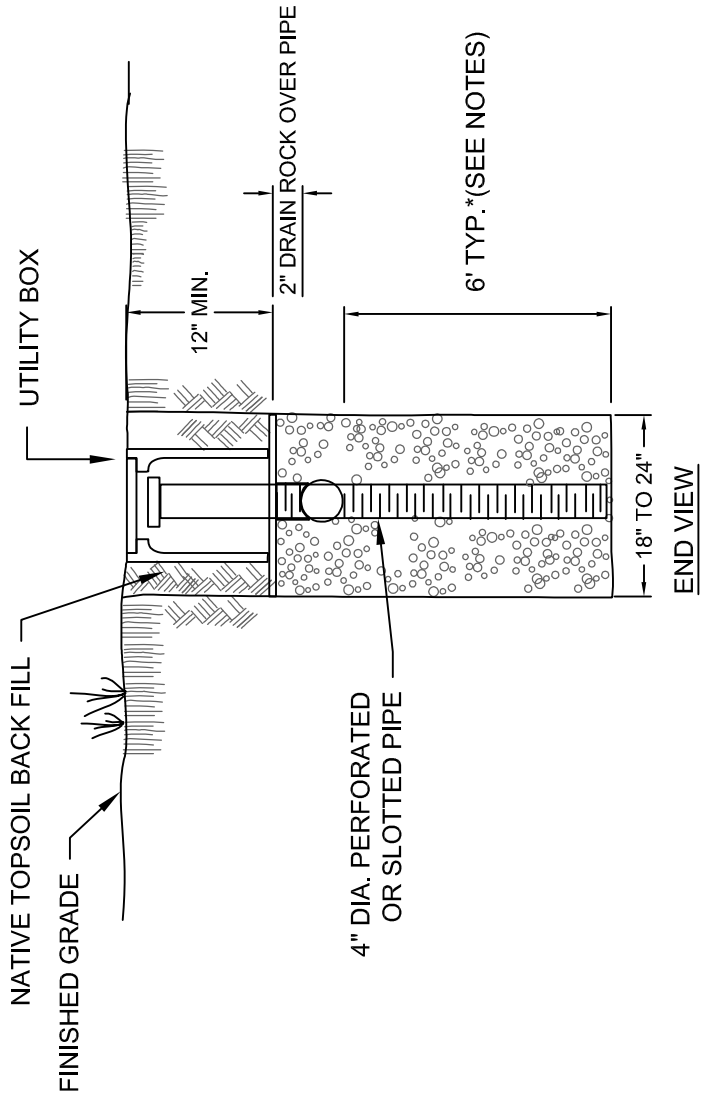
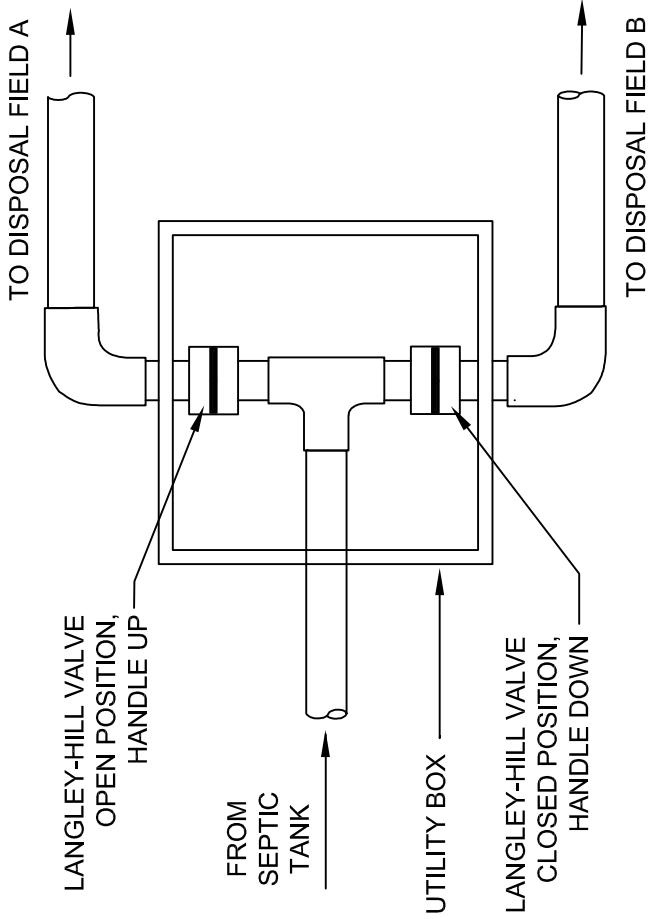
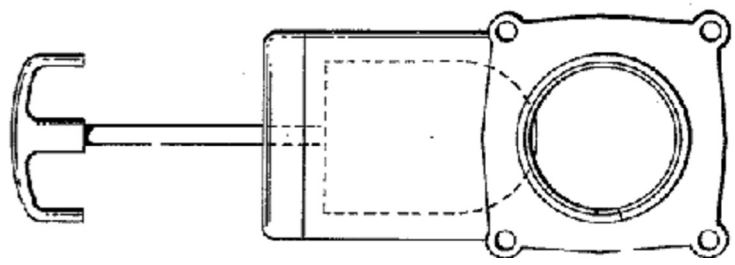

FIGURE 3-5

STANDARD GRAVITY TRENCH



PLAN VIEW



OPEN POSITION

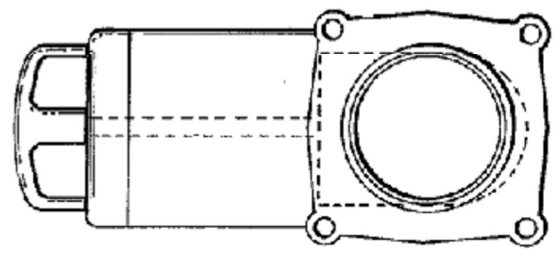

CLOSED POSITION

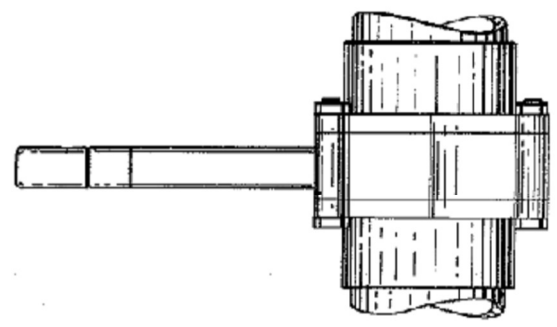

SIDE VIEW

SOURCE: U.S. PATENT #3,956,137
MAY 11, 1976

**LANGLEY-HILL
DIVERSION VALVE**

**FIGURE
3-6**

SECTION 4

ALTERNATIVE OWTS REQUIREMENTS

CONTENTS

- A. INTRODUCTION
- B. INTERMITTENT SAND FILTERS REQUIREMENTS
- C. PROPRIETARY TREATMENT UNITS REQUIREMENTS
- D. PRESSURE DISTRIBUTION TRENCH SYSTEMS REQUIREMENTS
- E. SUBSURFACE DRIP DISPERSAL REQUIREMENTS



A. INTRODUCTION

1. General

“Alternative OWTS” is a type of OWTS that utilizes either a method of wastewater treatment other than a conventional septic tank for the purpose of producing a higher quality wastewater effluent or a method of wastewater dispersal other than a gravity fed drain field trench for effluent dispersal. By this definition, any OWTS that includes the use of a pump system for effluent treatment and/or dispersal is considered to be an Alternative OWTS.

This Section provides technical guidance and requirements for the application, design, construction and management of various alternative onsite wastewater treatment and dispersal technologies deemed to be suited to the conditions and constraints in San Mateo County.

For all Alternative OWTS, a copy of the operation and maintenance guidelines must be kept onsite at all times and must be provided to any new owner upon property transfer.

2. General Pump System Requirements

Effluent pump systems may be considered when they offer a better alternative for the protection of public health and safety or the only safe opportunity for effluent distribution within a parcel. Due to problems inherent in mechanical devices, pump systems are to be considered only after gravity feed options have been explored and shown to be infeasible.

For any treatment or dispersal system using effluent pumps in any way (all considered alternative systems), plans must include specifications and sizing justification for any pump tank and pump (including pump performance curves); must show the elevations of the pump and the distribution or transfer piping at the highest elevation; show the calculations for total dynamic head through any piping and valves.

All systems using effluent pumps shall have an alarm system to alert the occupants of the residence of pump failure. Telemetry alarms to service companies are preferred, but not always required.

For all systems using effluent pumps, the septic tank must be sized as for a conventional system. For treatments system using pumps for recirculation, but gravity flow to distribution (e.g., no distribution pump tank required), there is no requirement for additional storage capacity beyond the septic/treatment unit storage. OWTS using pressure distribution must have a pump chamber consisting of a tank, pump, pump controls and alarm system. The pump chamber can be a separate unit or it can have



common wall construction with the septic tank (or pretreatment unit), as long as the required dosing volume and reserve volume can be achieved as described below.

The pump chamber must have sufficient volume to provide the desired dosing volume, plus a reserve volume. The reserve volume is the volume of the pump chamber between the high water alarm switch and the invert of the inlet pipe. It provides storage during power outages or pump failure.

A reserve volume equal to the estimated daily wastewater flow (150 gallons per room) is required for residential OWTS. This reserve volume may be reduced when an emergency gravity-flow trench of appropriate volume is installed as the reserve volume. As a general rule, the pump chamber volume will be the same as the septic tank volume.

3. Alternative Treatment Systems

Requirements are provided for the following alternative treatment systems:

- Intermittent Sand Filters
- Proprietary Treatment Units

County Ordinance allows for the future addition of other alternative treatment systems, as may be approved by Environmental Health and the appropriate California Regional Water Quality Control Board. Upon approval, such other alternative treatment systems will be incorporated into this Manual, including a listing of applicable requirements, similar to the information provided for intermittent sand filters and proprietary treatment units.

Dispersal systems receiving effluent from an alternative treatment system shall be sited, designed and constructed in accordance with the respective design and construction requirements for the particular type of dispersal system (e.g., conventional trenches, pressure distribution, drip dispersal), as specified in this Manual.

4. Alternative Dispersal Systems

Requirements are provided for the following types of alternative dispersal systems.

- Pressure Distribution Trench Systems
- Subsurface Drip Dispersal



County Ordinance allows for the future addition of other alternative dispersal systems, as may be approved by Environmental Health and the appropriate California Regional Water Quality Control Board. Upon approval, such other alternative dispersal systems will be incorporated into this Manual, including a listing of applicable requirements, similar to the information provided for pressure distribution trench systems and subsurface drip dispersal.

5. OPERATION AND MAINTENANCE GUIDELINES

Operation and maintenance guidelines for each alternative OWTS installation shall be supplied to the system owner by the designer, with a copy also provided to Environmental Health. Final approval of system installation shall be contingent upon confirmation by Environmental Health that required operation and maintenance guidelines have been provided.

Minimum items expected to be contained in the operation and maintenance guidelines include the following:

- General description of the OWTS, design capacity, and any special permit or operating conditions;
- Brief description of the key components and their function;
- For each component, describe recommended inspection and maintenance activities, including frequency; provide copies of manufacturer operation and maintenance instructions and “trouble-shooting” guides, as applicable;
- General preventative measures for proper use and maintenance of the OWTS (e.g., “Dos and Don’ts”);
- Copy of system plans or “as-built” drawings, as applicable.
- Contact information for the following:
 - Designer
 - Installer
 - Maintenance contractor
 - Environmental Health
- Other information, references or documents, as appropriate.



B. INTERMITTENT SAND FILTER SYSTEMS REQUIREMENTS

Description.

Intermittent sand filters (ISF) are used to provide supplemental treatment of septic tank effluent prior to discharge to the dispersal system. They are used to improve or restore the capacity of the dispersal field, reduce pathogenic bacteria and can provide additional nitrogen removal.

Sand filtration is well established in sanitary engineering practice for more than 100 years as a passive, reliable “biofilm” treatment process. An ISF consists of a packed-bed filter of medium-grained sand, designed for single pass-through treatment of septic tank effluent; it is sometimes referred to as a “single pass filter”.

Effluent from sand filters may be discharged to conventional leachfields and to any type of alternative dispersal system identified in the County Onsite Systems Manual. Effluent from an ISF designed and operated in accordance with these requirements will be considered to meet the criteria for “supplemental treatment”, not including pathogen removal where applicable.

Siting Criteria

- a. Sand Filter Treatment Unit. All siting criteria for septic tanks, as specified in the County Ordinance Section 4.84.120, shall also apply to intermittent sand filters and associated tanks and pumping units.
- b. Dispersal Systems Receiving Sand Filter Effluent. Dispersal systems receiving sand filter effluent are subject to all siting criteria for conventional septic tank-dispersal trench systems, with certain exceptions as noted. Exceptions allowed for supplemental treatment may include reduction in vertical separation distance to groundwater from standard 5 feet to minimum of 3 feet (measured from bottom of dispersal trench). Refer to the adopted requirements for the specific type of dispersal system for applicable requirements and supplemental treatment allowances.

Design Criteria

- a. Septic Tank Pretreatment. Sand filter treatment units shall be preceded by a septic tank, sized for the projected sewage flow for the structure or facility being served, determined in accordance with sewage flow estimation requirements in Part 3 of this Manual.



b. Pressure Dosing. Septic tank effluent shall be applied to the sand filter treatment unit by pressure dosing (i.e., pump system). The pressure distribution system shall be designed in accordance with accepted engineering practices to achieve, at a minimum:

- (1) Uniform dosing of effluent over the surface application area of the sand filter distribution bed;
- (2) Adequate flow rate, screening of effluent and suitable piping network to preclude solids accumulation in the pipes or clogging of discharge orifices;
- (3) Suitable access provisions for inspection, testing and adjustment of the pressure distribution system;
- (4) Dosing volume set to achieve a minimum of 3 to 5 doses per day at design flow conditions; and
- (5) At least one distribution lateral for every 36 inches of bed width.

Additional requirements for the design and construction of pressure distribution systems contained in “Requirements for Pressure Distribution Systems” shall also apply.

Also, where a sand filter is used in conjunction with a non-gravity-fed dispersal system, the dosing pump system for the sand filter shall provide emergency storage capacity equal to at least 1.5 times the daily wastewater flow, consistent with requirements for pump systems provided in Section 4 of this Manual.

c. Wastewater Application Rate. The wastewater application rate used for sizing the surface area of the sand filter shall be as follows:

- (1) 1.2 gpd/ft^2 for individual residential OWTS; and
- (2) 1 gpd/ft^2 for all commercial, industrial, institutional, and multi-residential OWTS

Reduction in the above wastewater loading rates or other provisions to insure the long-term integrity and performance of the sand filter may be required for high strength waste flows, such as those from restaurants.

d. Containment Liner. The sand filter shall be provided with an impermeable containment liner to prevent leakage out of or into the filter. The liner shall consist of: (a) 30 mil plastic; (b) reinforced poured-in-placed concrete; or (c) an equivalent impermeable structure or barrier.

e. Finished Grade. The finished grade of the sand filter shall be at or above the surrounding ground elevation. Above-ground installation shall be structurally supported with retaining wall(s), as required.



- f. Shape. The sand filter shall not be restricted as to its shape in plan view; i.e., it may be square, rectangular or an irregular shape.
- g. Multiple Units. The sand filter may be divided into compartments or multiple units.
- h. Sand Filter Media
 - (1) **Sand Specification.** The sand media shall be a medium to coarse sand that meets the gradation specifications in **Table SF-1**.
 - (2) **Sand Depth.** The minimum sand depth below the gravel distribution bed shall be 24 inches.

Table SF-1. Sand Media Specifications

Sieve Size	Percent Passing
3/8	100
#4	90-100
#10	62-100
#16	45-62
#30	25-55
#50	5-20
#60	0-10
#100	0-4
#200	0-2

Documentation of laboratory sieve analysis results for the proposed sand fill material shall be supplied to Environmental Health staff to verify conformance with the above specifications.

- i. Gravel Distribution Bed
 - (1) Material. The distribution bed shall consist of 3/8-inch double-washed pea gravel, substantially free of fines.



- (2) Depth. Pea gravel shall extend a minimum of 6 inches below the invert and 2 inches above the top of the distribution piping. If the distribution piping is installed with chambers, the pea gravel depth below the distribution pipe may be reduced from 6 inches to 4 inches, and the 2-inch pea gravel cover may be eliminated.
- j. Silt Barrier. The gravel distribution bed shall be covered in its entirety with a geotextile ("filter fabric") silt barrier. Filter fabric shall be either polyester, nylon or polypropylene, or any combination thereof, and shall be similar to that used for underdrain applications. Filter fabric shall be non-woven, be permeable, and shall not act as a wicking agent.
- k. Cover
- (1) Material. A soil cover shall be placed over the distribution bed, consisting of a medium, loamy-textured soil.
- (2) Depth. Soil cover depth shall be a minimum of 12 inches and a maximum of 18 inches over the top of the distribution bed. Soil cover shall be crowned or sloped to promote rainfall runoff.
- l. Underdrain
- (1) Material. The underdrain beneath the sand media shall consist of 3/8" washed pea gravel with 4-inch diameter perforated drain pipe, installed with perforations oriented down.
- (2) Depth. The pea gravel underdrain shall have a minimum depth of 9 inches.
- (3) Grade. The underdrain shall be constructed and the drain pipe set with a minimum grade of 1% toward the outlet point.
- (4) Watertight Outlet "Boot". The sand filter underdrain shall be equipped with a watertight outlet "boot" for connection of piping to the dosing tank. An exception to this is for intermittent sand filters that are equipped with an internal pump system for direct dosing to the disposal field (see paragraph #15 below).
- (5) Clean-out Riser. For clean-out and inspection purposes the upslope end of the perforated drain pipe in the underdrain shall be equipped with a vertical riser constructed of non-perforated pipe of equal diameter. The riser shall extend to finished grade of the sand filter.
- m. Air Manifold. An air manifold shall be installed within the pea gravel underdrain for the purpose of introducing forced air to into the sand filter media, as needed, for maintenance or drainage rehabilitation. The air



manifold shall consist of small diameter PVC piping, with drilled perforations (pointed down), and positioned above the perforated underdrain pipe. The manifold shall be connected to a vertical leader pipe that extends to the surface of the sand filter, fitted with a threaded pipe cap or plug at the top where a portable air-line can be connected.

- n. Inspection Wells. An inspection well shall be installed in the gravel distribution bed of each sand filter compartment. The inspection well shall extend from finished grade to the pea gravel-sand interface of the distribution bed and shall be perforated in the pea gravel zone only. Inspection wells shall be 2-inch to 4-inch diameter plastic pipe and fitted with a wrench-tight cap or pipe plug. Perforations shall consist of hacksaw slots at nominal 1" spacing; alternatively, commercially slotted pipe may be used. Inspection wells shall be sealed against surface infiltration with a bentonite or concrete annular seal through the soil backfill zone.
- o. Internal Pump System (ISF only). In lieu of gravity flow from the sand filter to the dispersal field (or dispersal field dosing system); an internal pump system may be installed within the intermittent sand filter for dosing directly to the dispersal field. In such applications:
 - (1) pump chamber shall be seated at or below the bottom of the underdrain;
 - (2) pump operating depth shall be entirely within the depth of the underdrain; and,
 - (3) storage volume equal to at least 50 percent of the disposal field dose volume shall be provided in the network of perforated drain pipe within the underdrain.

Engineering Plans & Construction

- a. Reference Guidelines. In addition to the requirements set forth herein, design and construction of sand filter systems shall utilize applicable guidelines contained in the following references:
 - (1) "Onsite Wastewater Treatment Systems Manual", U.S. Environmental Protection Agency, February 2002 and as amended.
 - (2) "Design Manual – Onsite Wastewater Treatment and Disposal Systems", U.S. Environmental Protection Agency, October 1980.
- b. Engineering Plans. Engineering plans for sand filter systems shall include:
 - (1) All relevant elevation data and hydraulic calculations;



- (2) Specific step-by-step construction guidelines and notes for use by the installer;
 - (3) Recommended make and model of all components;
 - (4) Recommended pump system components, with cut-sheet depicting float settings;
 - (5) Control panel programming; and
 - (6) An inspection schedule listing critical control points.
- c. Construction Inspection. At a minimum, inspection of the sand filter system installation should include the items listed below. Joint inspection by the designer, contractor, service provider, and Environmental Health staff may be required.
- (1) Pre-construction inspection where the construction staking or marking of the sand filter is provided and construction procedures discussed;
 - (2) Water tightness of septic tank and dosing (pump) tank;
 - (3) Sand filter dimensions, structure and liner;
 - (4) Underdrain piping and filter rock;
 - (5) Sand quality and placement;
 - (6) Layout and excavation of dispersal trenches and piping;
 - (7) Drain rock material and placement;
 - (8) Piping installation and hydraulic (“squirt”) test of the distribution system;
 - (9) Functioning and setting of all control devices; and
 - (10) Final Inspection to verify that all construction elements are in conformance with the approved plans and specifications, all inspection wells are installed; and erosion control has been completed;
 - (11) A letter from the designer that the alternative OWTS has been installed, operating, and tested in conformance with design specifications shall be provided to Environmental Health staff; and
 - (12) A valid, signed maintenance agreement between applicant/property owner and service provider shall be provided to Environmental Health staff.

MANAGEMENT REQUIREMENTS

Recommended minimum procedures and frequency for inspection, maintenance, monitoring and reporting activities for intermittent sand filter systems are included below in Table SF-2.



Table SF-2. Intermittent Sand Filter System Management Requirements

	Work	Minimum Frequency
Inspection	<ul style="list-style-type: none"> • Observe surface conditions on and around filter for effluent leakage, drainage/infiltration, erosion or other problems. • Check/measure water level in inspection wells in filter bed. • Perform all inspection work as recommended by designer or equipment manufacturer. • Perform inspection protocol for pump systems (per O&M manual and Performance Evaluation Guidelines, Part 5 of this Manual). • Record observations. 	<ul style="list-style-type: none"> • According to permit conditions, typically every 6 to 12 months, depending on system size, usage, and history.
Maintenance	<ul style="list-style-type: none"> • Purge laterals. • Perform squirt and balance laterals. • Exercise valves to ensure functionality. • Perform all maintenance work as recommended by designer or equipment manufacturer. • Record work done. 	<ul style="list-style-type: none"> • According to permit conditions, typically every 6 to 12 months, depending on system size, usage, and history. • Responsive maintenance as necessary.
Water Monitoring & Sampling	<ul style="list-style-type: none"> • Report observation findings and maintenance actions, including notation of problems and corrective actions. • Record dose counter and elapsed time meter readings from control panel. 	<ul style="list-style-type: none"> • According to permit conditions, if applicable.
Reporting	<ul style="list-style-type: none"> • Report findings to Environmental Health per permit requirements. • Standard report to describe findings, analyze performance, and detail actions taken. • Report emergency or failure conditions to Environmental Health immediately. 	<ul style="list-style-type: none"> • According to permit conditions, typically every year, depending on system size, usage, history, location.



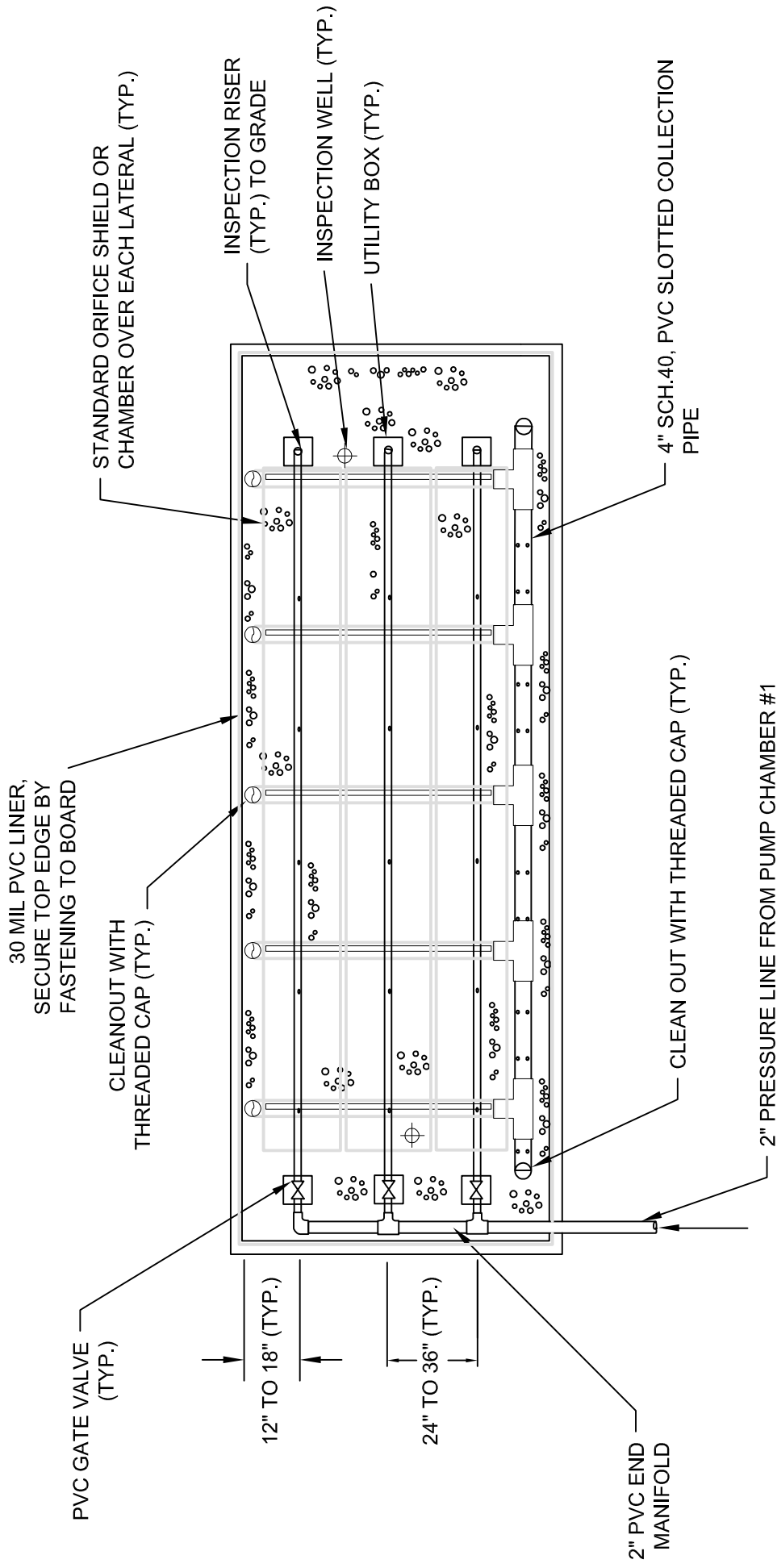
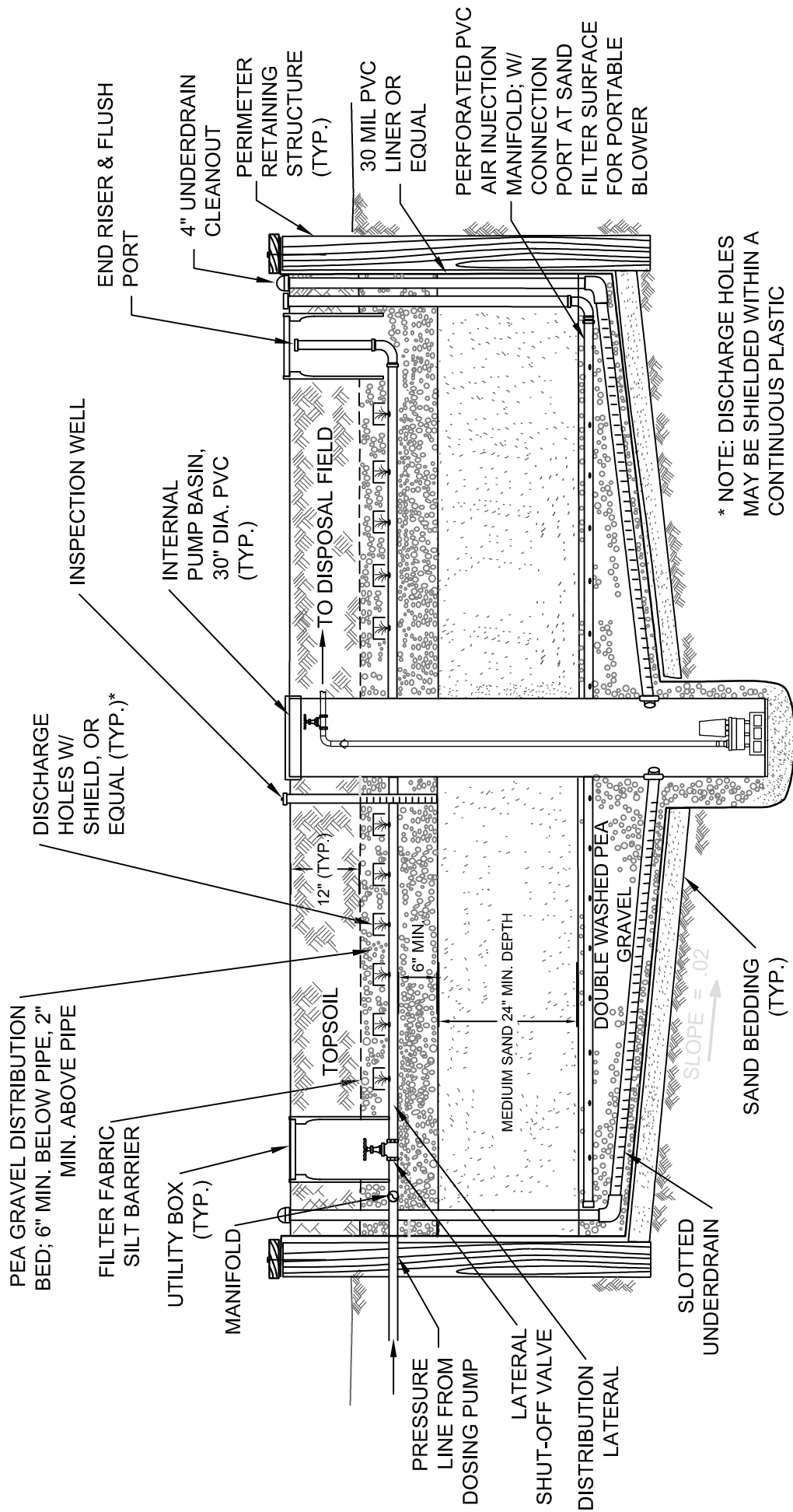

FIGURE
4-1

INTERMITTENT SAND FILTER
PLAN VIEW



* NOTE: DISCHARGE HOLES MAY BE SHIELDED WITH A CONTINUOUS PLASTIC CHAMBER, OR THEY MAY BE ORIENTED DOWN WITHOUT THE NEED FOR ANY SHIELD.

FIGURE 4-2

INTERMITTENT SAND FILTER WITH INTERNAL PUMP BASIN

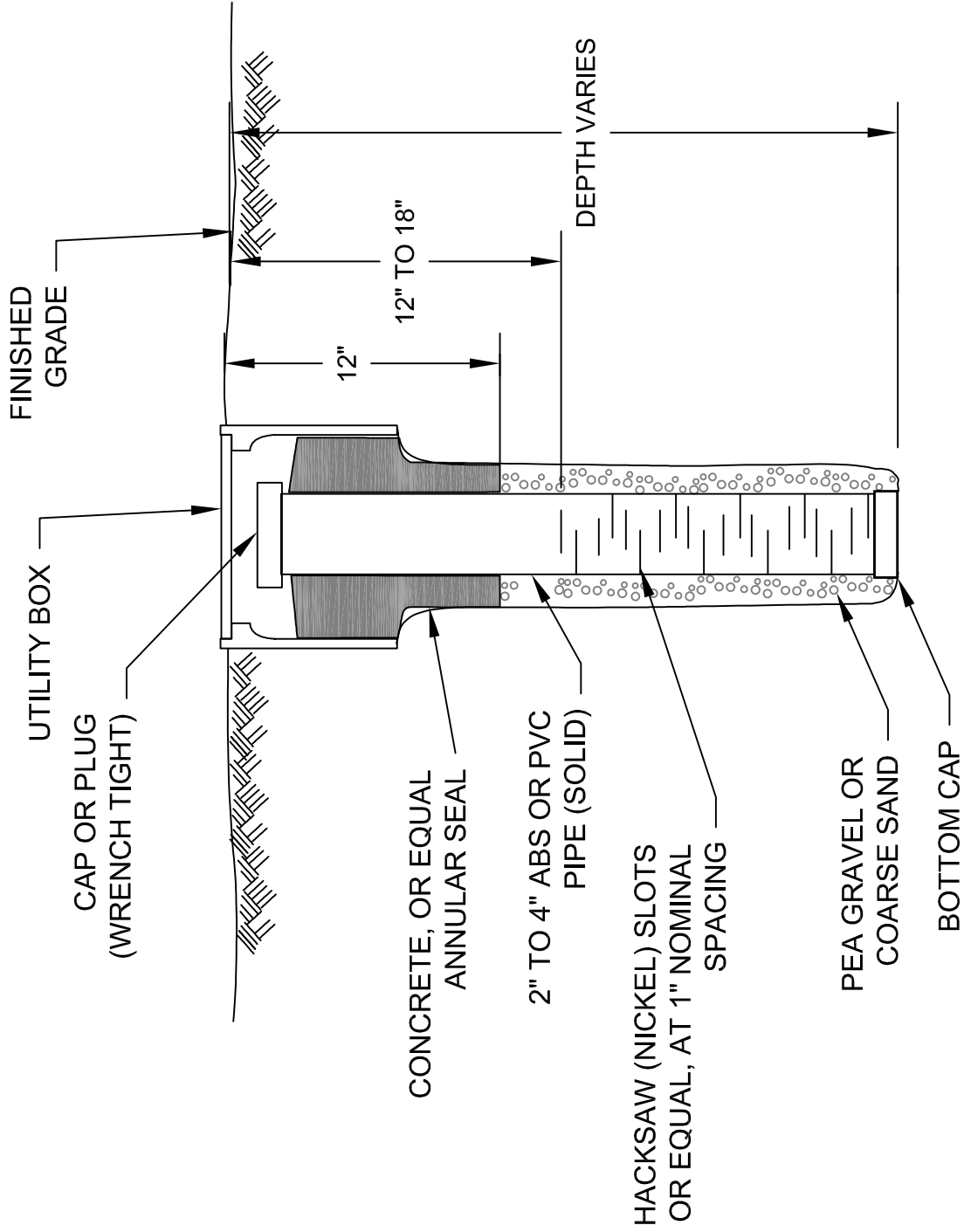

FIGURE 4-3

INSPECTION STANDPIPE (TYPICAL)

C. PROPRIETARY TREATMENT UNITS REQUIREMENTS

1. Description

Propriety treatment units cover a category of manufactured or “package” systems specifically developed for residential and other small-scale sewage treatment applications. Most proprietary designs currently available fall into two general categories: (1) aerobic treatment units (ATUs); and (2) media filters.

- a. **Aerobic Treatment Units (ATUs).** ATUs utilize forced air to oxidize the wastewater, promoting aerobic decomposition of the wastewater solids. These systems provide supplemental treatment of wastewater for improvement in dispersal field performance; they also provide varying degrees of nitrogen removal. In general, ATUs can be relied on to produce secondary quality effluent, better than 30 mg/L BOD and TSS. ATUs are generally not as effective in reducing pathogen levels as are systems that incorporate media filtration. However, some ATUs provide reduction in nitrogen levels equal to or greater than that provided by sand filters and other media filters.
- b. **Media Filters.** This includes proprietary designs that function similar to sand filters. In these systems, the sand is replaced with an alternate media (examples, but not limited to: peat, gravel or textile). Textile and other media filters have been found to produce effluent quality reasonably similar to recirculating sand filters, and provide similar capabilities in overcoming various soil and site constraints.

Effluent from proprietary treatment units may be discharged to conventional dispersal trenches and to any type of alternative dispersal system identified in this Onsite Systems Manual. Effluent from proprietary treatment units designed and operated in accordance with these guidelines will be considered to meet the criteria for “supplemental treatment”.

2. Siting Criteria

- a. **Treatment Unit.** All siting criteria for septic tanks, as specified in Part 3 of this Manual and in the County Ordinance Section 4.84.120, shall also apply to proprietary treatment units and associated tanks and pumping units.
- b. **Dispersal Systems Receiving Proprietary Treatment Effluent.** Dispersal systems receiving effluent from a proprietary treatment unit are subject to all siting criteria for conventional septic tank-dispersal trench systems, except as modified in accordance with adopted requirements for the specific type of



alternative dispersal system proposed, including any allowances for the incorporation of supplemental treatment. Allowances for supplemental treatment may include reduced vertical separation distances, increased wastewater application rates or modified slope restrictions. Refer to the part of this Section for the specific type of dispersal system for applicable requirements and supplemental treatment allowances.

3. Design and Construction Requirements

- a. NSF Standard 40. The proprietary treatment unit shall be listed by the National Sanitation Foundation (NSF) as meeting the NSF Standard 40, Class 1 performance evaluation, or have certification by a third-party listing agency as complying with NSF Standard 40 performance requirements. The treatment unit shall be manufactured and installed in accordance with the design specifications used to determine compliance to NSF Standard 40. This specification is applicable to treatment units for wastewater flows of up to 1,500 gpd and is based on compliance with US EPA standards for secondary treatment of municipal wastewater, including 30-day average effluent limits of 25 mg/L for CBOD₅ and 30 mg/L for TSS. Treatment units for flows in excess of 1,500 gpd will require certification by a third-party listing agency of equivalent performance.
- b. Design Sewage Flow. Sizing and design of proprietary treatment units shall be based on the projected sewage flow for the structure or facility being served, determined in accordance with sewage flow estimation guidelines in Part 3 of this Manual.
- c. Tanks. All tanks housing a proprietary treatment unit shall be structurally sound, water-tight and capable of withstanding 1,000 pounds of weight.
- d. Controls. Control panels shall be designed and configured in such a manner that, in the event of a treatment unit malfunction, an alarm system will be triggered and discharge from the treatment system to the dispersal field will be interrupted until the treatment unit malfunction is rectified. At a minimum, the alarm system shall include an audible and visual alarm located within the building served by the system.
- e. Emergency Storage Provisions. Where a proprietary treatment unit is used in conjunction with a non-gravity-fed dispersal system, the system shall provide emergency storage capacity equal to at least 1.5 times the daily wastewater flow, consistent with requirements for pump systems provided in this Manual. Depending on OWTS configuration, tank free board, pump tank capacity and



available gravity flow trench may be considered, at the discretion of Environmental Health staff.

- f. Compliance with Manufacturer Requirements. The designer and installer shall follow the proprietary manufacturer's design, installation, construction, and operations procedures.
- g. Engineering Plans. Engineering plan submittals for proprietary treatment units shall provide documentation of compliance with manufacturer requirements and sufficient design analysis to verify the appropriateness of the treatment unit for the proposed application. Engineering plans shall contain specific step-by-step construction guidelines and notes for use by the installer, including any manufacturer instructions.
- h. Installer Requirements. Anyone installing a proprietary treatment unit shall be trained and certified by the system manufacturer. Documentation verifying conformance to this requirement shall be provided to Environmental Health staff prior to system installation.
- i. Maintenance Contract. The applicant must demonstrate that a written maintenance agreement with a qualified service provider has been obtained for the proposed proprietary treatment unit to ensure satisfactory post-construction operation and maintenance. A maintenance agreement must be maintained valid for the life of the treatment unit.
- j. Construction Inspection. The following minimum inspections prior to commencing construction or covering any elements of the system shall be required. Joint inspection by the designer, installer, service provider, and Environmental Health staff may be required.
 - (1) Pre-construction inspection where the construction staking or marking of the treatment unit is to be placed and installation procedures are discussed;
 - (2) Testing of the treatment unit:
 - (a) Function and setting of all control devices and alarms.
 - (b) Water-tightness of septic tank, treatment tank(s), and dosing tank, as applicable.
 - (3) Drain Field:
 - (a) Layout and excavation of dispersal trenches and piping.
 - (b) Drain rock and perforated pipe materials and placement.
 - (c) Piping installation and hydraulic ("squirt") test of the distribution system.
 - (4) Final Inspection:



- (a) A letter from the designer that the alternative OWTS has been installed and is operating in conformance with design specifications shall be provided.
- (b) A valid, signed maintenance agreement between the applicant/property owner and service provider shall be provided.

4. Management Requirements

Recommended minimum procedures and frequency for inspection, maintenance, monitoring and reporting activities for proprietary treatment systems are outlined in Table P-1 below.

Table P-1. Proprietary Treatment System Management Requirements

	Work	Minimum Frequency
Inspection	<ul style="list-style-type: none"> • Inspection to be in accordance with manufacturer specifications. 	<ul style="list-style-type: none"> • According to permit conditions, typically every 6 to 12 months, depending on system size, usage, and history.
Maintenance	<ul style="list-style-type: none"> • Perform all maintenance as required and in accordance with equipment manufacturer specifications. 	<ul style="list-style-type: none"> • According to permit conditions, typically every 6 to 12 months, depending on system size, usage, and history.
Water Monitoring & Sampling	<ul style="list-style-type: none"> • Monitoring to be in accordance with manufacturer specifications. 	<ul style="list-style-type: none"> • If required, according to permit conditions, typically every 6 to 12 months, depending on system size, usage, and history.
Reporting	<ul style="list-style-type: none"> • Report findings to Environmental Health per permit requirements. • Standard report to describe findings, analyze performance, and detail actions taken. • Report crisis or failure conditions to Environmental Health immediately. 	<ul style="list-style-type: none"> • According to permit conditions, typically every year, depending on system size, usage, history, location.



D. PRESSURE DISTRIBUTION TRENCH SYSTEMS REQUIREMENTS

1. Description

Pressure distribution (PD) systems are a variation of a conventional gravity dispersal system that use a pump and small-diameter pressure piping to achieve broad, uniform distribution of wastewater throughout the dispersal system for improved soil absorption and better treatment of percolating effluent. Pressure distribution can be used in conjunction with regular rock-filled trenches receiving septic tank effluent (PD trench systems), or for shallow/chambered dispersal fields or subsurface drip dispersal with supplemental treatment systems. This Section covers requirements for PD trench systems; shallow/chambered and drip dispersal alternatives are covered in subsequent sections of this Manual.

2. Applications

Pressure distribution trench systems are permitted and/or required for the following situations:

- a. Areas with ground slopes exceeding 35%;
- b. Areas with percolation rates between 1.0 and 0.75 inches per hour (61 to 80 MPI);
- c. To allow reduction of vertical separation to groundwater (below trench bottom) from 5 feet to 3 feet;
- d. For any OWTS where pumping from the septic tank to the drain field is required;
- e. For large flow systems, e.g., with dispersal field lengths (primary) exceeding 500 lineal feet; and
- f. Others as may be determined necessary due to site-specific soil, geology or other conditions.

3. Siting Criteria

- a. **Setbacks.** Horizontal setback requirements for PD trench systems shall be those applicable to conventional dispersal fields, as specified in the County Ordinance Section 4.84.120.
- b. **Vertical Separation Requirements.**



- (1) Depth to Groundwater. Minimum depth to seasonal high groundwater for PD trench systems, as measured from trench bottom, shall be five (5) feet, but may be reduced to three (3) feet for dispersal trench designs utilizing no more than four (4) square feet of effective application area per lineal foot of trench.
 - (2) Soil Depth. Minimum depth of soil, as measured from trench bottom to impermeable soil or rock, for PD trench systems shall be three (3) feet.
- c. Percolation Rate.
- (1) Average percolation rate for PD trench systems shall be within the range of 12 inches per hour to 0.75 inches per hour (5 to 80 minutes per inch, MPI), as determined in accordance with standard percolation requirements for conventional dispersal trenches.
 - (2) Any drain field located in an area demonstrating percolation rates of between three-fourths (0.75) and ninety-nine hundredths (0.99) inches per hour is required to utilize pressure distribution.
- d. Ground Slope.
- (1) Ground slope in areas used for PD trench systems shall be less than 50 percent.
 - (2) Any drain field located on slopes exceeding 35% is required to utilize pressure distribution.
 - (3) Any PD trench system located on slopes greater than 20 percent shall require the completion of a geotechnical report and slope stability analysis as specified in the County Ordinance Section 84.120 and Section 2 of this Manual.
- e. Dual System. Two PD trench dispersal fields, each one hundred percent of the total size required for the design sewage flow, shall be installed and interconnected with an approved flow diversion device (pressure-rated), intended to allow alternate use of the two fields.

4. Design Criteria

- a. Treatment. The following treatment requirements shall apply in connection with the use of PD trench systems:
 - (1) Primary (septic tank) treatment shall be the minimum level of treatment.



- (2) Supplemental treatment, using an approved alternative treatment system identified in this Manual, may be used and/or required to comply with provisions applicable to OWTS within identified Advanced Protection Management areas in the County or in other circumstances as deemed necessary due to site-specific soil, geologic or other conditions.
 - (3) Screening of effluent ahead of effluent pump system, as applicable.
- b. Design Sewage Flow. PD trench systems shall be designed on the basis of the projected sewage flow for the structure or facility being served, determined in accordance with sewage flow estimation requirements in Section 3 of this Manual.
 - c. Pressure Dosing. Septic tank effluent shall be applied to the PD trench system by pressure dosing, utilizing a pump system. The pressure distribution system shall be designed in accordance with accepted engineering practices to achieve, at a minimum:
 - (1) Uniform dosing of septic tank effluent throughout the system of PD trenches;
 - (2) Adequate flow rate, screening of effluent and suitable piping network to preclude solids accumulation in the pipes or clogging of discharge orifices;
 - (3) Suitable access provisions for inspection, testing and adjustment of the pressure distribution system; and
 - (4) Dosing volume to achieve minimum of 3 to 5 doses per day at design flow conditions.
 - d. Dispersal Trenches. PD trenches shall conform to the same design and construction requirements as conventional trenches, per Section 4 of this Manual, with the exception that the piping system shall consist of pressure piping rather than gravity piping. Both primary and secondary fields must be fed by the pump system.
 - e. Pressure Distribution Piping.
 - (1) Pressure-Rated Pipe Material. All pipe, fittings and valves shall be pressure-rated PVC pipe, minimum 150 psi.
 - (2) Solvent Welded. All joints in the pressure piping system shall be solvent welded.



- (3) Pipe Sizing. All pressure distribution pipes and fittings, including transport lines, manifolds, laterals and valves, must be adequately sized for the design flow, and shall be designed to minimize frictional losses to the maximum extent practicable.
 - (4) Thrust Blocks. Concrete thrust blocks, or equivalent restraint, shall be provided at sharp changes in piping directions.
 - (5) Shut-off Valves. The distribution lateral for each trench shall be fitted with a shut-off valve to adjust or terminate the flow to individual trenches. This valve may be either a ball or gate valve, and shall be located in a utility/valve box.
 - (6) Lateral End Riser. The end of each lateral shall be fitted with a 90° long sweep to facilitate line cleaning and hydraulic testing. The end riser pipe shall also be fitted with a ball valve and/or threaded end cap or plug, housed in a valve box.
- f. Pump System. The pump system shall be: (a) appropriate for sewage applications; (b) of the size and type to meet the hydraulic design requirements; and (c) designed and constructed in accordance with pump system requirements provided in Section 4 of this Manual.
- g. Trench Sizing.
- (1) Residential OWTS. Trench sizing for drain field areas with percolation rates of one inch per hour (60 MPI) or faster shall be in accordance with requirements for “Drain Field Sizing – Residential”, as specified for Conventional OWTS in Section 4 of this Manual.

Areas with stabilized percolation rates between three-fourths (0.75) and ninety-nine hundredths (0.99) inches per hour shall require:

- (a) Up to three bedrooms – two (2) lines, each of one hundred eighty (180) feet total trench length;
 - (b) Each additional bedroom – add sixty (60) feet total trench length to each line.
 - (c) 100% reserve area equivalent to the proposed drain field.
- (2) Multifamily and Non-Residential. Trench sizing shall be in accordance with requirements for “Drain Field Sizing – Multifamily and Non-



Residential”, as specified for Conventional OWTS in Section 3 of this Manual.

- h. Inspection Standpipes. A minimum of three (3) inspection standpipes shall be installed within and around PD trench systems for the purpose of checking groundwater levels, and may also be used for water quality sampling, as needed. Inspection standpipes shall extend to a depth of at least 5 feet below the bottom of the PD trenches. The inspection standpipes shall be located and constructed as follows:
 - (1) One shall be located upslope of the dispersal field, typically 10- to 15-feet away, to serve as a background or control point;
 - (2) One shall be located within the dispersal field, typically between trenches near the center of the field;
 - (3) One shall be located down-slope of the dispersal field, typically 10 to 25 feet horizontally from the lowest trench(es), and positioned to provide a representative point for monitoring the area estimated to be in the probable flow path of percolating wastewater; and
 - (4) Inspection standpipes shall be constructed of 2" to 4" diameter pipe, equipped with a wrench-tight cap or pipe plug, and a bottom cap. All standpipes shall be perforated beginning at a depth of 18 inches below grade and extending to the bottom of the pipe. Perforations shall consist of hacksaw (nickel) slots at nominal 1" spacing, or equivalent commercially-perforated pipe. To prevent surface water infiltration, inspection standpipes shall be sealed/stabilized with a concrete annular seal (or equivalent) to a depth of 12 inches, minimum.

5. Engineering Plans & Construction

- a. Reference Guidelines. In addition to the requirements set forth herein, design and construction of PD trench systems shall utilize applicable guidelines contained in the following references:
 - (1) "Onsite Wastewater Treatment Systems Manual", U.S. Environmental Protection Agency, February 2002 and as amended; and
 - (2) "Design Manual – Onsite Wastewater Treatment and Disposal Systems", U.S. Environmental Protection Agency, October 1980.
- b. Engineering Plans. Engineering plans for PD trench systems shall include:
 - (1) All relevant elevation data and hydraulic calculations;



- (2) Specific step-by-step construction guidelines and notes for use by the installer;
 - (3) Erosion control plans for any site over 20% slope;
 - (4) Recommended make and model of all components;
 - (5) Recommended pump system components, with cut-sheet depicting float settings;
 - (6) Control panel programming; and
 - (7) An inspection schedule listing critical control points.
- c. Construction Inspection. At a minimum, inspection of the PD trench system installation should include the items listed below. This is in addition to inspection work required for a supplemental treatment system, if used. Joint inspection by the designer, contractor, service provider, and Environmental Health may be required.
- (1) Pre-construction inspection where the construction staking or marking of the various system components is provided and construction procedures discussed;
 - (2) Water tightness of septic tank and dosing (pump) tank;
 - (3) Layout and excavation of dispersal trenches and piping;
 - (4) Drain rock material and placement;
 - (5) Piping installation and hydraulic (“squirt”) test of the distribution system;
 - (6) Functioning and setting of all control devices; and
 - (7) Final inspection to verify that all construction elements are in conformance with the approved plans and specifications, all inspection standpipes are installed; and erosion control has been completed.
 - (8) A letter from the designer that the Alternative OWTS has been installed, operating, and tested in conformance with design specifications shall be provided to Environmental Health staff; and
 - (9) A valid, signed maintenance agreement between applicant/property owner and service provider shall be provided to Environmental Health staff.



6. Management Requirements

Recommended minimum procedures and frequency for inspection, maintenance, monitoring and reporting activities for pressure distribution trench systems are outlined in Table PD-1 above.

Table PD-3. Pressure Distribution Trench System Management Requirements

	Work	Minimum Frequency
Inspection	<ul style="list-style-type: none"> • Conduct routine visual observations of disposal field and downslope area and surroundings for wet areas, pipe leaks or damage, soil erosion, drainage issues, abnormal vegetation, or other problems. • Perform all inspections of pump and appurtenances (per system O&M manual, and Performance Evaluation Guidelines in Section 5.3 of this Manual). 	<ul style="list-style-type: none"> • Every 6 to 12 months.
Maintenance	<ul style="list-style-type: none"> • Purge laterals, squirt and balance. • Exercise valves to ensure functionality. • Perform all maintenance work as recommended by equipment manufacturer for any special valves or other components. • Investigate and repair erosion, drainage or other disposal field problems, as needed. • Investigate and perform distribution system corrective work, as required. • Record work done. 	<ul style="list-style-type: none"> • Distribution system maintenance annually. • Other maintenance as required.
Water Monitoring & Sampling	<ul style="list-style-type: none"> • Measure and record water levels in trench observation wells. • Measure and record water levels in dispersal field monitoring wells, as applicable, per permit requirements. • Obtain and analyze water samples from monitoring wells, as applicable, per permit requirements. 	<ul style="list-style-type: none"> • Measure trench water levels annually. • Other monitoring according to permit conditions, as applicable.
Reporting	<ul style="list-style-type: none"> • Report findings to Environmental Health per permit requirements. • Standard report to include dates, observation well and monitoring well readings and other data collected, work performed, corrective actions taken, and performance summary. • Report public health/water quality emergency to Environmental Health staff immediately. 	<ul style="list-style-type: none"> • According to permit conditions, typically every year, depending on system size, usage, history, location.



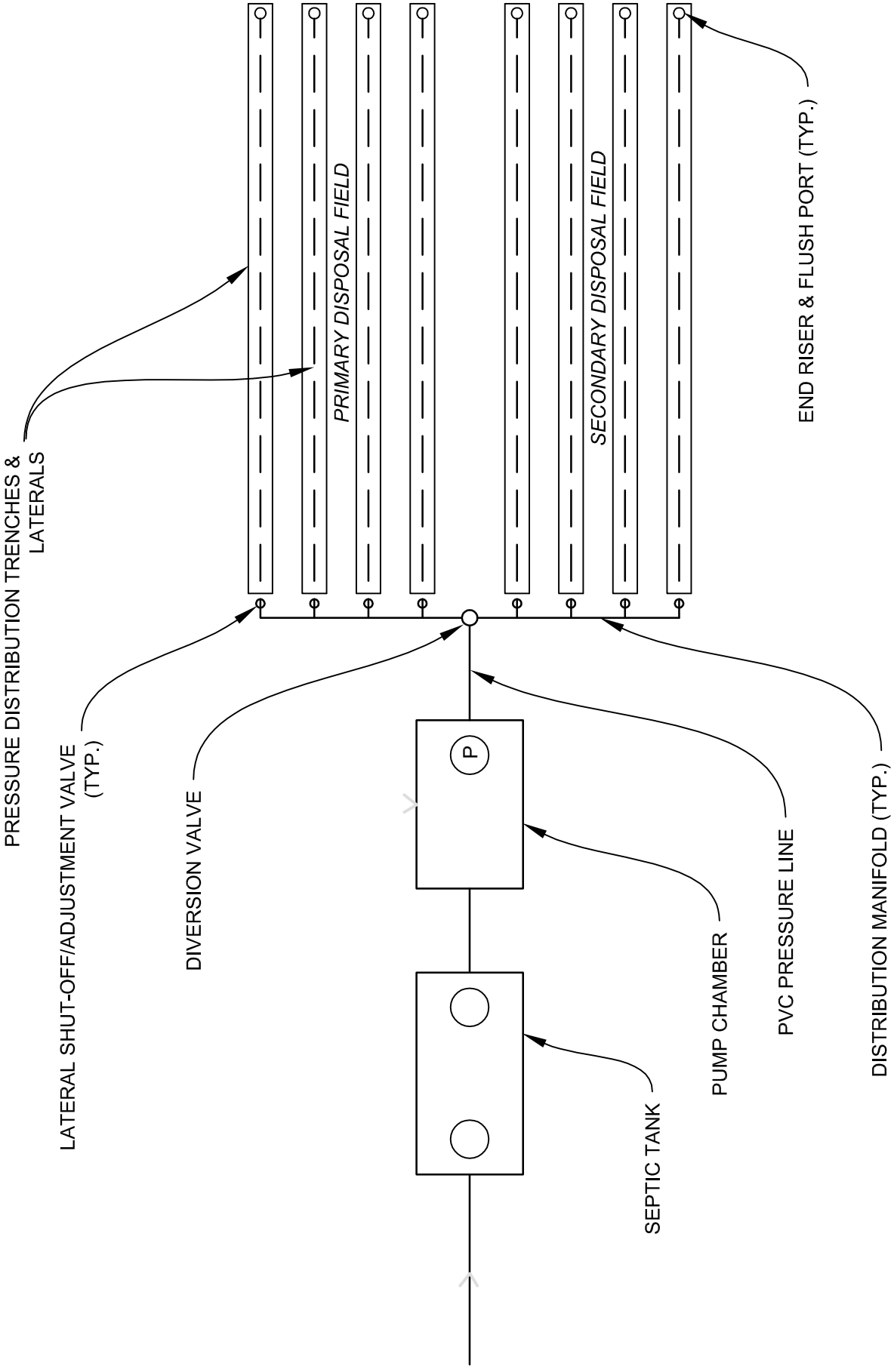
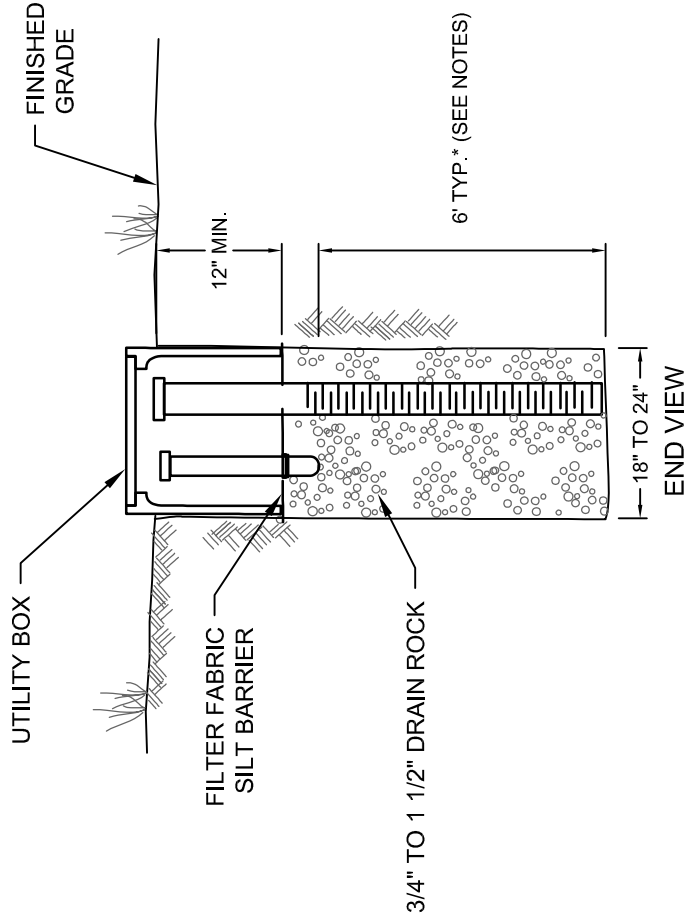
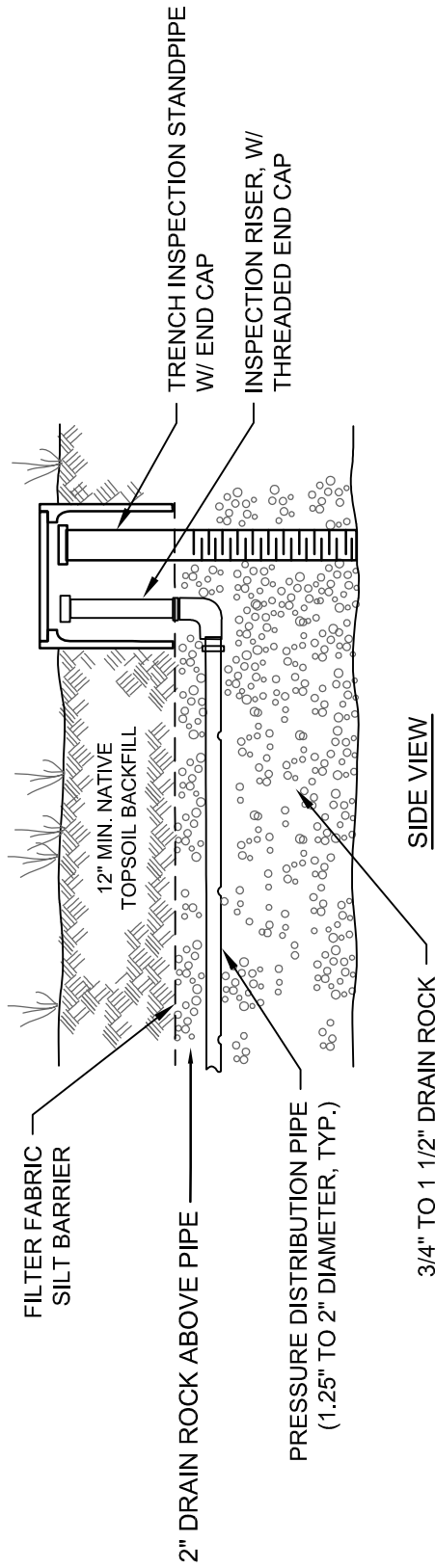

FIGURE 4-4

PRESSURE DISTRIBUTION SYSTEM SCHEMATIC



NOTES:

1. FOR RESIDENTIAL OWTS, DRAIN FIELDS OF LESSER DEPTHS (<6 FT. SIDEWALL DEPTH) BUT EQUIVALENT OVERALL SIDEWALL AREA MAY BE PERMITTED SUBJECT TO THE APPROVAL OF ENVIRONMENTAL HEALTH.
2. FOR MULTI-FAMILY AND NON-RESIDENTIAL OWTS:
 - THE "EFFECTIVE INFILTRATIVE AREA" SHALL BE LIMITED TO FOUR (4) SQUARE FEET PER LINEAL FOOT OF TRENCH LENGTH, COUNTING ONLY TRENCH SIDEWALL AREA BELOW THE INVERT OF THE PIPE;
 - UNDER CERTAIN (FAVORABLE) SOIL AND SITE CONDITIONS, THE EFFECTIVE INFILTRATIVE SURFACE MAY BE INCREASED TO UP TO A MAXIMUM OF EIGHT (8) SQUARE FEET PER LINEAL FOOT.

FIGURE 4-5

PRESSURE DISTRIBUTION TRENCH

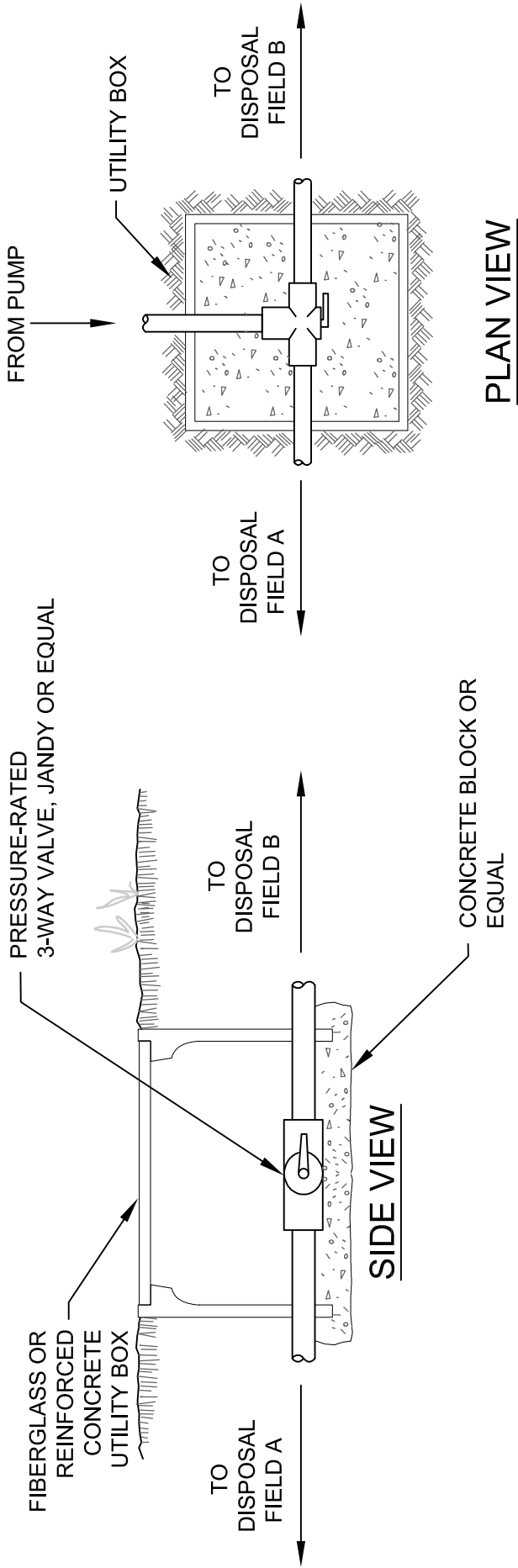

PLAN VIEW

SIDE VIEW

**FIGURE
4-6**

**PRESSURE DISTRIBUTION
3-WAY DIVERSION VALVE**

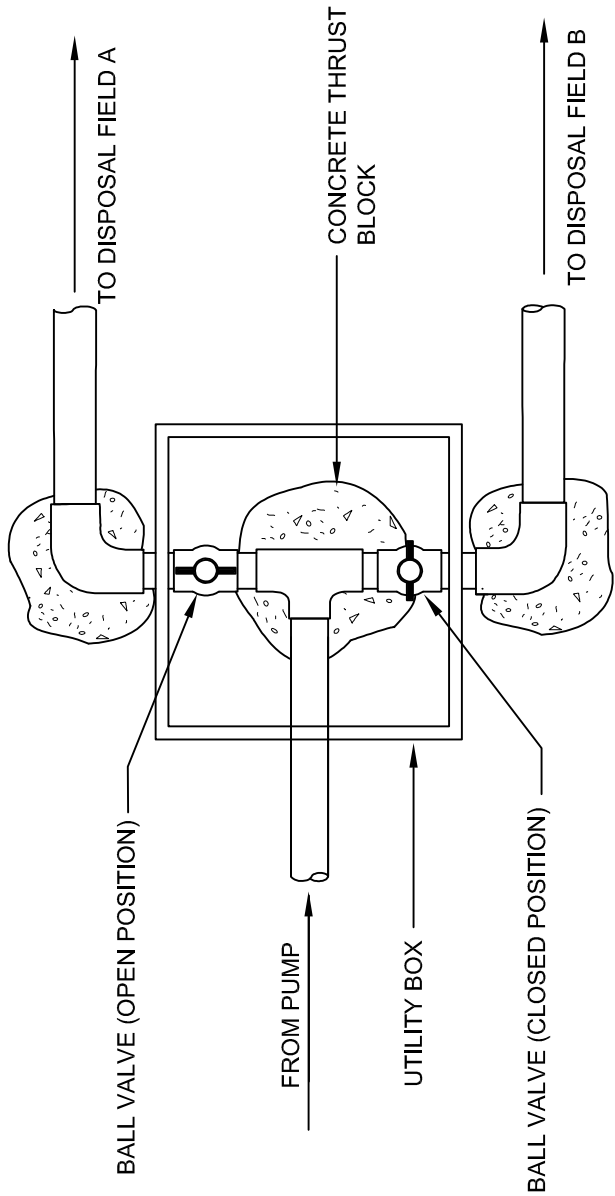

PLAN VIEW

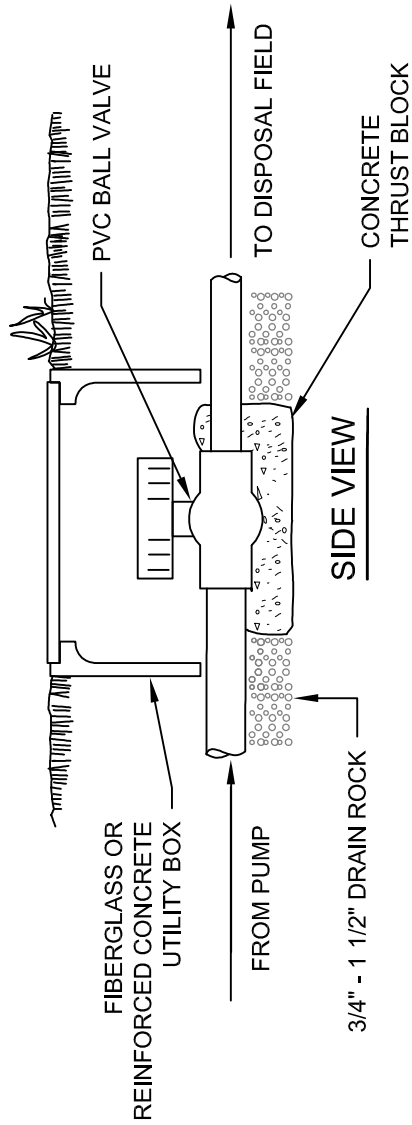

SIDE VIEW

FIGURE 4-7

PRESSURE DISTRIBUTION DIVERSION VALVE W/ DUAL BALL VALVES

E. SUBSURFACE DRIP DISPERSAL REQUIREMENTS

1. Description

Subsurface drip dispersal is a method for disposal of treated wastewater that uses special drip tubing designed for use with wastewater. The dripline is placed normally 9 to 12 inches below ground surface and makes use of the most biologically active soil zone for distribution, nutrient uptake and evapotranspiration of the wastewater. A drip dispersal system is comprised of small-diameter ($\frac{1}{2}$ " to 1") laterals ("driplines"), usually spaced about 24 inches apart, with small-diameter emitters ($\frac{1}{8}$ ") located at 12 to 24 inches on-center along the dripline. Effluent is conveyed under pressure to the laterals, normally with timed doses. Prior to dispersal the effluent requires supplemental treatment. See Figure 4-8 for a schematic of typical shallow drip dispersal system elements.

Drip dispersal has several advantages, including: (a) it can be effective in very shallow soil conditions since it distributes the wastewater very uniformly to substantially all of the available soil in the field; (b) it can be installed in multiple small discontinuous "zones", allowing the hydraulic load to be spread widely rather than concentrated in one main area; (c) installation on steeper slopes causes less soil disturbance and erosion or slope stability hazards; and (d) water movement away from the drip emitters is substantially by unsaturated/capillary flow, which maximizes contact with and treatment by the soil.

2. Applications

Subsurface drip dispersal systems may be permitted for the following situations:

- a. Areas with ground slopes less than 50%;
- b. Areas with percolation rates between 12.0 and 0.75 inches per hour (5 to 80 MPI);
- c. To allow reduction of vertical separation to groundwater (below trench bottom) from 5 feet to 3 feet;
- d. Where pumping from the septic tank to the drain field is required; and
- e. Others as may be determined appropriate due to site-specific soil, geology or other conditions.

Per County Ordinance Section 4.84.145, subsurface drip dispersal may be permitted by Environmental Health for new construction on any legally-created parcel where: (a) Environmental Health determines such system would provide equal or greater protection to public health and the environment than a conventional or pressure-



dosed trench dispersal field system; (b) a primary and reserve leaching system for a conventional or pressure-dosed trench dispersal system can also be accommodated on the property, if required. The subsurface drip dispersal system may overlap the area reserved for the conventional or pressure-dosed trench dispersal system, as long as the operation of the shallow subsurface drip dispersal system will not affect the potential future function of the trench dispersal system.

3. Siting Criteria

- a. Setbacks. Horizontal setback requirements for subsurface drip dispersal systems shall be those applicable to conventional disposal fields, as specified in the County Ordinance Section 4.84.120.
- b. Vertical Separation Requirements.
 - (1) Depth to Groundwater. Minimum depth to seasonal high groundwater, as measured from the bottom of the dripline shall be 3 feet.
 - (2) Soil Depth. Minimum depth of soil, as measured from the bottom of the dripline to impermeable soil or rock, shall be 3 feet.
- c. Percolation Rate. The average soil percolation rate in the proposed subsurface drip dispersal field area shall not be faster than 12 inches per hour (5 minutes per inch) nor slower than 0.75 inches per hour (80 minutes per inch), determined in accordance with procedures prescribed by in Section 2 of this Manual. Percolation testing for drip dispersal systems shall be conducted at 12 to 24-inch depth.
- d. Ground Slope.
 - (1) Ground slope in areas used for drip dispersal shall be less than 50 percent.
 - (2) Any drip dispersal system located on slopes greater than 20 percent shall require the completion of a geotechnical report and slope stability analysis as specified in the County Ordinance Section 4.84.120 and Section 2 of this Manual.
- e. Dual System. Two drip dispersal fields, each one hundred percent of the total size required for the design sewage flow, shall be installed and interconnected with an approved flow diversion device (pressure-rated), to allow alternate or combined use of the two fields.



4. Design Criteria

- a. Treatment: The following treatment requirements shall apply in connection with the use of subsurface drip dispersal systems:
 - (1) Wastewater effluent discharged to any drip dispersal system shall be treated to at least a secondary level through an approved supplemental treatment system, in accordance with applicable guidelines provided in this Manual.
 - (2) All drip dispersal systems shall include a filtering device capable of filtering particles larger than 100 microns; this device shall be located downstream of the supplemental treatment system.
 - (3) Any additional requirements that may be assigned in connection with criteria for use in Advanced Protection Management Areas.
- b. Design Sewage Flow: Subsurface drip dispersal systems shall be designed on the basis of the projected sewage flow for the structure or facility being served, determined in accordance with sewage flow estimation guidelines in Section 3 of this Manual.
- c. Wastewater Application Rates: Wastewater application rates used for sizing drip dispersal fields shall be based on soil percolation rates as measured in the field by appropriate percolation testing. Wastewater application rates should be in accordance with the criteria in Table DD-1 below. In applying these criteria, the wastewater application area refers to the ground surface area encompassed by the drip dispersal field.



Table DD-1. Wastewater Application Rates for Subsurface Drip Dispersal Fields

Soil Percolation Rate (minutes per inch)	Soil Percolation Rate (inches per hour)	Wastewater Application Rate (gpd/ft ²)
5-10	12-6	1.2
11-20	5.99-3	1.0
21-30	2.99-2	0.7
31-45	1.99-1.31	0.6
46-60	1.3-1.0	0.4
61-80	0.99-0.75	0.2

d. Dripfield Sizing.

(1) Minimum sizing of the dripfield area shall be equal to the design wastewater flow divided by the applicable wastewater application rate from Table DD-1 above. As an example, for a design flow of 450 gpd in soils having an average percolation rate between 46 and 60 MPI, the minimum required dripfield area for a single (100%) would be:

- $450 \text{ gpd} / 0.4 \text{ gpd/ft}^2 = 1,125 \text{ ft}^2$

(2) For sizing purposes, effective ground surface area used for drip field sizing calculations shall be limited to no more than 4.0 square feet per drip emitter. For example, 200 lineal feet of dripline with emitters at 2-foot spacing would provide a total of 100 emitters (200/2) and could be used for dispersal to an effective area of up to 400 ft² (100 emitters x 4 ft²/emitter). Conversely, if wastewater flow and percolation design information indicate the need for an effective area of 1,000 ft², the dripline design and layout would have to be configured to provide a minimum of 250 emitters spaced over the required 1,000 ft² of dispersal area.

(3) Dripfields may be divided into multiple zones which may be located in different areas of a site, as desired or needed to provide the required dripfield size. A single continuous dripfield area is not required. However, any areas proposed for drip dispersal shall be supported by field



observations and measurements to verify conformance with soil suitability and other site requirements. Differences in soil conditions and percolation characteristics from one zone to another may require the use of correspondingly different wastewater application rates and dripfield sizing for each zone.

- e. **Pressure Dosing.** Secondary-treated effluent shall be delivered to the dripfield by pressure, employing a pump system and timed dosing. The pressure distribution system shall be designed in accordance with accepted engineering practices and manufacturer recommendations for drip dispersal systems to achieve, at a minimum:
- (1) Uniform dosing of treated effluent;
 - (2) An adequate dosing volume and pressure per manufacturer's guidelines;
 - (3) Adequate flow rate, final filtering of effluent and suitable piping network to preclude solids accumulation in the pipes and driplines or clogging of discharge emitters;
 - (4) A means of automatically flushing the filter and driplines at regular intervals; and
 - (5) Suitable access provisions for inspection, testing and adjustment of the dripfield and components.

Additional requirements for design and construction of pressure distribution piping systems contained in requirements for Pressure Distribution Systems in Section 4.3 above shall also apply.

- f. **Pump System:** The pump system shall be: (a) appropriate for sewage applications; (b) of the size and type to meet the hydraulic design requirements; and (c) designed and constructed in accordance with pump system requirements provided in Section 4 of this Manual.
- g. **Dripline Material:** Dripline shall be manufactured and intended for use with secondary quality wastewater, with minimum 45 mil tubing wall thickness, bacterial growth inhibitor(s), and means of protection against root intrusion.
- h. **Dripfield Layout:** The bottom of each dripline row shall be level and parallel to the slope contour.
- i. **Dripline Depth:** The dripline depth shall be installed at a depth between nine (9) and twelve (12) inches below native grade. Deeper placement of driplines may be considered by Environmental Health on a case-by-case basis.



- j. Length of individual driplines: The maximum dripline length shall be designed in accordance with accepted engineering practices and in accordance with the manufacturer's criteria and recommendations.
- k. Line and Emitter Spacing: Line and emitter spacing shall be designed as appropriate for soil conditions, slope, and contour. There shall be a minimum spacing of 12 inches between emitters and no emitter shall be located less than 12 inches from the supply and return manifolds.
- l. Dual System Operation. Unless exempted by Environmental Health, all drip dispersal systems shall be installed as dual (200% capacity) drip fields, and shall normally be operated with both fields in use. Doses may be alternated among different zones in both the primary and secondary fields, or all zones may be dosed simultaneously. Secondary drip fields should not be left dormant for long periods of time (e.g., more than a few weeks at a time).
- m. Inspection Standpipes. A minimum of three (3) inspection standpipes, minimum 3 feet in depth, shall be installed for the purpose of monitoring groundwater levels or for water quality sampling within and around subsurface drip dispersal fields as follows:
 - (1) One standpipe shall be located within the dripfield area.
 - (2) One standpipe shall be located 10 to 15 feet up-gradient of the dripfield.
 - (3) One standpipe shall be located 10 to 15 feet down-gradient of the dripfield.
 - (4) Inspection standpipes shall be constructed of 2" to 4" diameter pipe (or equivalent), equipped with a wrench-tight cap or pipe plug and a bottom cap. All standpipes shall be perforated beginning at a depth of 12 inches below grade and extending to the bottom of the pipe. Perforations shall consist of hacksaw (nickel) slots at nominal 1" spacing, or equivalent commercially-slotted pipe. Inspection standpipes shall be sealed with a concrete annular seal (or equivalent) for stability and to prevent surface infiltration.

5. ENGINEERING PLANS AND CONSTRUCTION

- a. Reference Guidelines. Installation of subsurface drip dispersal systems shall be in accordance with applicable manufacturer guidelines and recommendations.



- b. Engineering Plans. Engineering plans for subsurface drip dispersal systems shall include:
- (1) All relevant elevation data and hydraulic calculations;
 - (2) Specific step-by-step construction guidelines and notes for use by the installer;
 - (3) Erosion control plan for any site over 20%;
 - (4) Recommended make and model of all components;
 - (5) Recommended pump system components, with cut-sheet depicting float settings;
 - (6) Control panel programming; and
 - (7) An inspection schedule listing critical control points.
- c. Construction Inspection. At a minimum, inspection of the drip dispersal system installation should include the following. This is in addition to inspection work required for the treatment system. Joint inspection by the designer, contractor, and Environmental Health staff may be required.
- (1) Pre-construction inspection where the construction staking or marking of the drip lines, supply and return piping, pump system and appurtenances is provided and construction procedures discussed;
 - (2) Water tightness of effluent dosing (pump) tank;
 - (3) Drip field layout, piping materials and installation, and all associated valves and connections;
 - (4) Hydraulic testing of the drip system;
 - (5) Functioning and setting of all control devices; and
 - (6) Final Inspection to verify that all construction elements are in conformance with the approved plans, specifications, and manufacture recommendations; all inspection standpipes are installed; and erosion control has been completed.
 - (7) A letter from the designer that the Alternative OWTS has been installed and is operating in conformance with design specifications shall be provided.



- (8) A valid, signed maintenance agreement between the applicant/property owner and service provider shall be provided.

F. MANAGEMENT REQUIREMENTS

Recommended minimum procedures and frequency for inspection, maintenance, monitoring and reporting activities for subsurface drip dispersal systems are outlined in Table DD-2 below.



Table DD-2. Drip Dispersal System Management Requirements

	Work	Minimum Frequency
Inspection	<ul style="list-style-type: none"> • Conduct routine visual observations of drip field, downslope area and surroundings for wet areas, pipe leaks or damage, soil erosion, drainage issues, abnormal vegetation, gophers or other problems. • Conduct routine physical inspections of system components, including valves, filters, and headworks box(es). • Perform special inspections of drip field at time of any landscaping work or other digging in drip field area. • Perform inspections of dosing pump(s) and appurtenances (per system O&M manual, and Performance Evaluation Guidelines, Section 5 of this Manual). • Record observations. 	<ul style="list-style-type: none"> • Every 6 to 12 months.
Maintenance	<ul style="list-style-type: none"> • Manually remove and clean filter. • Clean and check operation of pressure reducing valves. • Clean flush valves and vacuum release valves. 	<ul style="list-style-type: none"> • Clean filter every 6 months. • Other maintenance annually.
Water Monitoring & Sampling	<ul style="list-style-type: none"> • Measure and record water levels in dispersal field monitoring wells, as applicable, per permit requirements. • Obtain and analyze water samples from dispersal field monitoring wells, as applicable, per permit requirements. 	<ul style="list-style-type: none"> • According to permit conditions, if applicable.
Reporting	<ul style="list-style-type: none"> • Report findings to Environmental Health per permit requirements. • Standard report to include dates, monitoring well and other data collected, work performed, corrective actions taken, and performance summary. • Report public health/water quality emergency to Environmental Health immediately. 	<ul style="list-style-type: none"> • According to permit conditions, typically every year, depending on system size, usage, history, location.



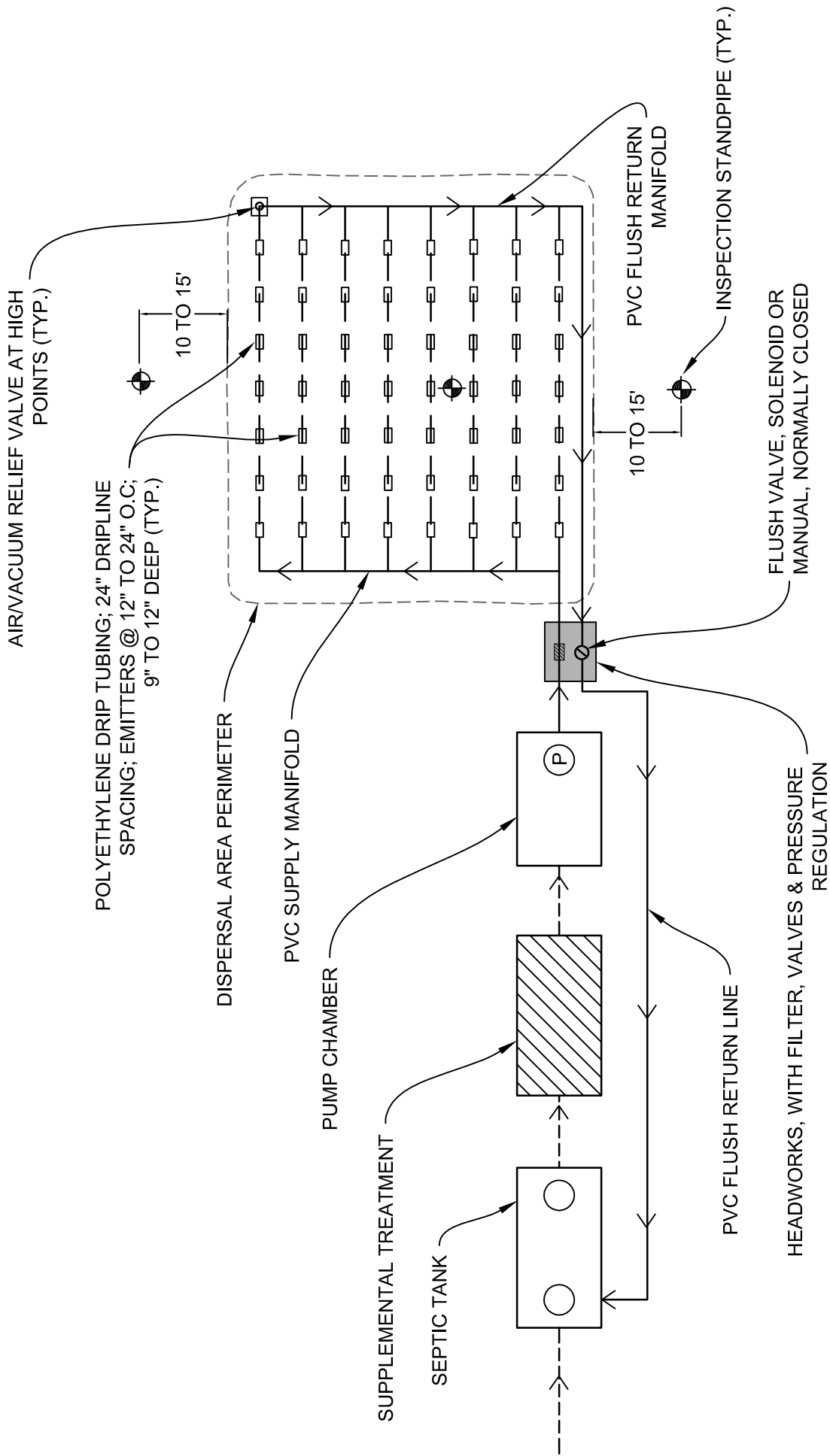

FIGURE

4-8

DRIP DISPERSAL SYSTEM SCHEMATIC

SECTION 5

OWTS PERFORMANCE, MONITORING, AND EVALUATION

CONTENTS

- A. OWTS OPERATIONAL PERFORMANCE REQUIREMENTS
- B. OWTS MONITORING REQUIREMENTS
- C. OWTS PERFORMANC EVALUATION GUIDELINES



A. OWTS OPERATIONAL PERFORMANCE REQUIREMENTS

1. General

- a. All onsite wastewater treatment systems (OWTS) shall function in such a manner as to:
 - (1) Be sanitary and not create a health hazard or nuisance;
 - (2) Prevent backup or release of wastewater or wastewater effluent into the structure(s) being served by the OWTS; and
 - (3) Not discharge wastewater or wastewater effluent onto the ground surface or into surface water, or in such a manner that groundwater may be adversely impacted.
- b. All OWTS and the individual components shall meet the performance requirements for the specific site conditions and application for which they are approved.
- c. All OWTS shall be operated in compliance with applicable performance requirements particular to the type of system, the facility served, and the site conditions.

2. Conventional Systems

- a. All septic tanks shall be structurally sound, watertight, provide clarified effluent, have adequate space available for sludge and scum storage, and operate in such a manner as to not create odors or vector attraction, be properly vented, and have a functional baffle and sanitary tees for inlet/outlet from tank chambers.
- b. Dispersal systems shall: (a) have adequate dispersal capacity for the structures and/or uses served; (b) not result in seepage or saturated soil conditions within 12 inches of ground surface in or adjacent to the dispersal field; and (c) be free from soil erosion or instability.
- c. Effluent shall not continuously pond at a level above the invert (bottom) of the perforated distribution pipe in the dispersal trench or serial distribution overflow line, as applicable.
- d. All components of the OWTS shall be functional and in proper working order.

3. Supplemental Treatment

In addition to meeting criteria in 1 and 2 above, supplemental treatment systems shall comply with the following performance requirements.



- a. Effluent Quality. Effluent produced by all supplemental treatment systems shall comply with the following minimum 30-day average constituent limitations:

Constituent	(1) For Use with Trench Systems	(2) For Use with Drip Dispersal Systems	(3) Where Pathogen or Nitrogen treatment Required*
Biochemical Oxygen Demand (BOD), mg/L	30	20	Per (1) or (2), as applicable
Total Suspended Solids (TSS), mg/L	30	20	Per (1) or (2), as applicable
Fecal Coliform, MPN/100 ml	N/A	N/A	200
Total Nitrogen, % reduction (effluent/influent)	N/A	N/A	50%

*Due to: (1) proximity to public water supply well or surface water intake per SWRCB OWTS Policy and the County Ordinance Section 4.84.120 or (2) location within an Advanced Protection Management Area subject to SWRCB OWTS Policy supplemental treatment limits (10.9 and/or 10.10). Where applicable, additional requirements for pathogens include: (a) minimum 3-ft separation to groundwater below dispersal field; and (b) minimum 12 inches of soil cover over dispersal piping. Note: TMDL requirements may be stricter than requirements of this Section.

- b. Sand Filters. Sand filters shall:

- (1) be operated to maintain uniform effluent distribution throughout the sand filter bed;
- (2) not result in continuously ponded effluent on the distribution bed infiltrative surface;
- (3) be operated and maintained to prevent channeling of flow, erosion of the sand media or other conditions that allow short-circuiting of effluent through the system;
- (4) not result in leakage of effluent through the sand filter liner or supporting structure; and



- (5) conform to applicable requirements for pressure distribution in Section A.4 below.
- c. Proprietary Treatment Units. Proprietary treatment units shall comply with the following:
 - (1) The unit and its components shall be structurally sound, free from defects, be watertight, and not create odor or vector attraction nuisance.
 - (2) The unit shall be operated in accordance with the approved manufacturer and certification/listing organization standards.

4. Alternative Dispersal System

In addition to the requirements in 1. and 2. above, alternative dispersal systems shall also comply with the following.

- a. Pressure Distribution Systems.
 - a. Pump tanks, risers and lids shall be structurally sound, watertight and store wastewater effluent in such a manner as to not create odors or vector attraction.
 - b. Pumps, floats, alarms and associated controls shall be in good condition and operate in accordance with design specifications.
 - c. Dispersal field and components shall:
 - (a) be operable and in good condition;
 - (b) maintain uniform distribution of effluent throughout the dispersal field;
 - (c) not result in continuously ponded effluent in the dispersal trench (or bed) to a level above the invert (bottom) of the distribution pipe; and
 - (d) in the case of pressure-dosed sand trenches, not result in continuously ponded effluent above the sand interface.
- b. Subsurface Drip Dispersal Systems. Subsurface drip dispersal systems and components shall:
 - (1) not result in seepage or saturated soil conditions above the depth of the dripline within or anywhere along the perimeter of the dripfield;
 - (2) be free from erosion, slumping or other soil disturbance that threatens to expose or cause damage to drip dispersal tubing or appurtenances;



- (3) conform to applicable requirements for pressure distribution in A.4 above;
and
- (4) be operated and maintained in accordance with manufacturer recommendations.

B. OWTS MONITORING REQUIREMENTS

1. General

A monitoring program will be established for each alternative OWTS as a condition of the operating permit at the time of permit issuance, and may be amended at the time of permit renewal. The purpose of this monitoring is to ensure that the alternative OWTS is functioning satisfactorily to protect water quality and public health and safety.

2. MONITORING ELEMENTS

The monitoring requirements will vary depending on the specific type of alternative OTWS, typically including the following:

- a. Recording of wastewater flow based on water meter readings, pump event counter, elapsed time meter, in-line flow meter, or other approved methods;
- b. Measurement and recording of water levels in inspection risers/pipes in the dispersal field;
- c. Inspection and observation of pump operation and other mechanical equipment;
- d. Water quality analysis of selected water samples taken from points in the treatment process, from groundwater monitoring wells, or from surface streams or drainages; typical water quality parameters include total and fecal coliform, nitrate, BOD, and suspended solids;
- e. General review and inspection of treatment and dispersal area for evidence of seepage, effluent surfacing, erosion or other indicators of system malfunction;
and
- f. Other monitoring as recommended by the system designer or equipment manufacturer.



3. **Monitoring Frequency**

The required frequency of monitoring for each alternative OWTS installation will be established in the operating permit, generally in accordance with the following minimum schedule:

- Years 1 through 4 of operation: semi-annual monitoring
- Years 5 and beyond: annual monitoring

Monitoring frequency may be increased for larger flow OWTS (e.g., >2,500 gpd), where warranted because of the complexity of the design or sensitive nature of the site (i.e., impaired areas). Monitoring frequency may be increased for any system if problems are experienced.

4. **Monitoring Responsibility**

Monitoring of alternative OWTS shall be conducted by or under the supervision of one of the following:

- a. Registered Civil Engineer;
- b. Professional Geologist;
- c. Registered Environmental Health Specialist; or
- d. Other onsite wastewater maintenance providers recognized by Environmental Health as having experience in the construction and/or operation of OWTS as evidenced by either of the following:
 - (1) possession of a valid contractor's license (A, C-36 or C-42); or
 - (2) completion of an onsite wastewater certification training course by a third party entity, such as the California Onsite Wastewater Association (COWA), National Association of Waste Transporters (NAWT), National Sanitation Foundation (NSF), or other acceptable training program as determined by the director.

Additionally, Environmental Health staff may require third-party or County inspection and monitoring of any alternative OWTS where deemed necessary because of special circumstances, such as the complexity of the system or the sensitive nature of the site. The costs for such additional monitoring would be the responsibility of the owner.



5. Reporting

Monitoring results shall be submitted to Environmental Health staff in accordance with reporting guidelines provided in this Manual and as specified in the operating permit. The monitoring report shall be signed by the party responsible for the monitoring. Notwithstanding formal monitoring reports, Environmental Health staff shall be notified immediately of any system problems observed during system inspection and monitoring that threaten public health or water quality.

6. Post-Seismic Inspections

In addition to regular inspection and monitoring activities, post-seismic inspection and evaluation of alternative OWTS located in high-risk seismic areas may be required in the event of an earthquake causing significant ground shaking in the region, as determined by Environmental Health staff in consultation with other County departments. Environmental Health staff will be responsible for issuing appropriate notices when such inspections are required; those conducting the inspections will be required to report the inspection results to Environmental Health staff. The purpose of such inspections will be to assess and document any damage to the OWTS and to implement corrective measures, as needed, in a timely manner. Post-seismic inspection shall be in accordance with the standard inspection requirements specified in the applicable operating permit for each OWTS, along with any additional requirements that may be prescribed by Environmental Health staff, in consultation with other County departments, based on the intensity, location and other aspects of the particular seismic event.

7. Data Review

Environmental Health staff will, from time-to-time, compile and review monitoring and inspection results for alternative OWTS and will provide a summary of results to the San Francisco Bay and Central Coast Regional Water Quality Control Boards as part of required OWTS-water quality assessment per the State Water Board's OWTS Policy. Based on this review, Environmental Health staff may require corrective action for specific properties or certain types of alternative OWTS, or general changes in monitoring and inspection requirements.

C. OWTS PERFORMANCE EVALUATION GUIDELINES

1. Purpose and Performance Criteria

San Mateo County Ordinance requires the completion of an OWTS inspection and performance evaluation in connection with certain types or level of changes or additions to an existing building served by an OWTS. Guidelines for these



inspections are prescribed below. These guidelines may also be useful and employed for other circumstances, such as OWTS inspections in connection with property transfers, for lending institutions, etc.

The purpose of these inspections is to determine, on an individual basis, whether an existing OWTS is functional and meets minimum standards of performance established by the San Mateo County Environmental Health Division. The following performance criteria are established as minimum requirements:

- a. There is no surfacing effluent at any time;
- b. The effluent is not discharged directly to groundwater; i.e., the dispersal trenches do not extend to or below the seasonal high groundwater level;
- c. There is always positive flow to the dispersal field from the septic tank, with no backup to the tank or house plumbing during high groundwater conditions;
- d. There is an adequately sized septic tank for the structure being served and it must be serviceable - e.g. access risers for maintenance. The septic tank must be water tight and constructed of approved materials; and
- e. There is no indication that the existing OWTS is adversely affecting any beneficial uses of surface water or groundwater.

2. Inspection Responsibility

The inspections may be carried out by any of the following:

- a. Registered Civil Engineer;
- b. Registered Environmental Health Specialist;
- c. Professional Geologist (also meeting the requirements of 4a or 4b below); or
- d. Other onsite wastewater maintenance providers recognized by Environmental Health as having experience in the construction and/or operation of OWTS as evidenced by either of the following:
 - (1) possession of a valid contractor's license (A, C-36 or C-42); or
 - (2) completion of an onsite wastewater certification training course by a third party entity, such as the California Onsite Wastewater Association (COWA), National Association of Waste Transporters (NAWT), National Sanitation Foundation (NSF), or other acceptable training program as determined by the director.



Maintenance provider shall provide documentation to Environmental Health staff demonstrating minimum qualifications.

The individual conducting the field inspection work shall be familiar with the testing and inspection procedures outlined in this document.

3. Background Data

Prior to conducting the field inspection, compile and review background information pertaining to the property, structures and OWTS. This should include permit information, site plan, "As Built" drawings of the OWTS, prior inspection results, etc. Important information to look for are the location of the septic tank and dispersal field, the locations of all buildings, decks, cut banks, creeks, wells, reserve area, direction and percentage of slope, any other items which may affect the OWTS, and identification of the reserve dispersal field area(s) and evaluate any conflicting encroachment by buildings or other site development.

4. Initial Site Observations

- a. First, walk the property to confirm the location of the septic tank, dispersal field, and other pertinent features of the system.
- b. Next check setbacks between the existing dispersal field and reserve areas and any man-made structures, e.g., to confirm no building foundations recently added within or too close to the existing dispersal field or expansion areas.
- c. Check septic tank and dispersal field areas for any obvious signs of existing system problems such as surfacing effluent, odors, gray water bypasses, saturated soil in the dispersal field area, or any other condition that may suggest an existing or impending problem.
- d. Determine if the system has dual dispersal fields and, if so, locate and check the diversion valve: (a) to see that it is functional; and (b) to determine which field is in service. Note all observations. To the extent possible, determine the length of each line and depth of pipe (below ground surface). This may require probing with a fiberglass rod or hand excavation.



5. Septic Tank Inspection

- a. Access Risers. First, locate the septic tank and determine if permanent access risers have been installed on the tank. If equipped with risers, check their general condition. Ideally, the risers should be properly grouted or sealed to the top of the septic tank to prevent groundwater and/or surface water intrusion. The lids of the risers should also be properly sealed to prevent odors or the entry of insects, (e.g., flies, mosquitoes, etc.). Any observed defects in the access risers should be noted. If the tank lacks access risers, this information should be noted; and the property owner should be provided information about access risers and advised to have them installed.
- b. Opening the Tank. After inspecting the access risers carefully remove the riser lids. Take care to prevent or minimize damage and disturbance to adjacent vegetation and yard area. Concrete lids are heavy and may be "cemented" in place by silt. A steel bar or other suitable tool may be needed to assist in opening the lids. During the tank inspection process, personnel should wear protective boots and gloves (neoprene) to guard against infection from pathogenic organisms.
- c. Structural Condition. Once the tank is open observe and probe the structural condition of the septic tank to check for any obvious signs of cracking or other structural defects in the tank. A steel rod is used to probe the walls and bottom of the tank. Normally, the tank will need to be pumped-out to perform this procedure.

Inspect the inlet and outlet sanitary "tees" to make sure they are in satisfactory condition, properly positioned, and free of scum accumulation, rocks, root matter or other obstructions. Note any problems and assess whether or not additional tests or observations are necessary to verify the structural integrity of the tank.

- d. Liquid Level. Measure and note the liquid level in the tank with respect to the outlet pipe. In a properly functioning system, the level in the tank should be even with the invert (i.e., bottom) of the outlet pipe. If the liquid level is below the outlet pipe, the tank is probably leaking. If the liquid is above the pipe, the dispersal field is either flooded or the line to the field is obstructed or possibly set with an improper grade.



- e. Tank Capacity. Determine the capacity of the septic tank (in gallons) from as-built plans or from measurements of the width, length and depth (below outlet pipe) of the tank. Compare the capacity with the established water use/wastewater flow rates for the property or building size (e.g., bedroom count).

6. Hydraulic Load Test

- a. General. After tank inspection, proceed with a hydraulic load test (HLT) of the septic tank and dispersal field. The described here is only for conventional gravity-fed dispersal trench systems, and does not apply if the system utilizes a pump. A separate test for pump systems is described in the next section.

The HLT is conducted by surcharging the septic tank with about 150 gallons of water over a 20 to 30-minute period, and then observing the rise of water in the tank and the subsequent draining process. Tracer dye, added to the tank during the test, may be used to assist in investigating the possible contribution of effluent where surface wetness/seepage is suspected or observed.

Alternatively, a portable water meter can be installed between the house faucet and the hose to directly measure the water volume added.

- b. Test Procedures. Step-by step procedures for the HLT are as follows:
 - (1) Measure the location of the static water level in the septic tank (at the outlet side) as an initial reference point.
 - (2) Begin surcharging the tank with water to start the HLT.
 - (3) Observe any rise in the liquid level at the outlet pipe and measure the final level at the end of filling. Typically, the liquid level will rise from an inch or two, at which point the liquid level should stabilize for the remainder of filling, and then return to the initial level in a matter of minutes after filling is stopped.
 - (4) After the filling cycle is finished, observe the water level decline in the tank until it returns to the initial level; note how much time this takes. If the initial level is not attained within 30 minutes, terminate the test and note water level.



- c. **System Rating.** Based on the water level readings during the test, assign a hydraulic performance rating to the system in accordance with the guidelines provided in Table 1 below. It should be emphasized that these are guidelines only; and special circumstances may be cause for modifying the evaluation and rating of a particular system. A system receiving a "Failed" rating will likely require upgrading and/or additional investigation to determine the underlying cause(s).

6. Final Dispersal System Inspection

At the completion of the HLT, check the dispersal system area and down-slope areas again for indications of surfacing effluent, wetness, or odors. If any of these conditions exist as a result of the HLT, this would likely be considered evidence of system failure. If the field observations of wetness are not obviously the result of the HLT, further investigation may be necessary to determine if the dispersal system is failing and the cause of the failure. Additional investigative work may include water quality sampling (for total and fecal coliform, ammonia and nitrate) or dye testing. The cause of seepage could be related to gopher holes, site drainage or erosion problems, excessive water use or simply the age of the system.

**TABLE 1
HYDRAULIC LOAD TEST RATING GUIDELINES**

RATING	SEPTIC TANK RESPONSE TO HYDRAULIC LOADING
EXCELLENT	No noticeable rise in water level during filling.
SATISFACTORY	Maximum water level rise of about 2 inches, with decline to initial level within about 15 minutes after end of filling.
MARGINAL	Maximum water level rise of about 3 inches, with decline to initial level within about 30 minutes after end of filling.
POOR	Water level rise of more than 3 inches, with decline not reaching initial level within 30 minutes after end of filling.
FAILED	Water level rise of more than 3 inches, with no noticeable decline within 30 minutes after end of filling.



8. Pump Systems

For systems equipped with an effluent pump, the following inspection procedures should be followed. This is in addition to inspection of the septic tank as described under Section E. "Septic Tank Inspection".

- a. Pump Test. The pump test is conducted by adding sufficient water to the basin to activate the pump "ON" control, and observing the operation of the system over at least one pumping cycle. The total amount of water added should be about 150 gallons, to approximate the same hydraulic loading of the dispersal field as for gravity systems.

Using a garden hose, the water may be added to the outlet side of the septic tank, or directly to the pump basin. If filling the basin directly, be careful to minimize turbulence and disturbance of sediment or sludge that may have collected in the basin. This can be best accomplished by directing the stream of water against the interior side of the chamber, rather than directly toward the bottom of the pump chamber.

Observe the filling of the basin, and note and measure the point at which the pump is activated. Immediately stop the filling operation and observe the pumping cycle until the pump shuts off. While the pump is discharging, examine the piping system (where exposed) for any leaks. Even small leaks could be a forewarning of possible breaks in the pressure line at some point in the future; and these should be corrected as soon as possible.

Note and measure the depth at which the pump shuts off, and calculate the volume of water between the "ON" and "OFF" measurements. Compare this dose with the design dose volume specified for the system. If the dose is too high or too low, float controls should be readjusted to correct the dose. Any adjustments to the pump system should be done by a licensed and properly qualified contractor (not by the inspector, unless so qualified).

The pumping cycle (from "ON" to "OFF") level should be timed and the results recorded on the inspection form. Typically, if the pump is sized and operating properly, pump operation lasts about 1 to 5 minutes per dose. Pump cycles lasting longer than this may indicate a flooded dispersal field and/or pump or piping deficiencies. If this is observed, it should be noted and further investigation of the pump and dispersal field should be conducted to determine the specific cause.



Dividing the pump volume (in gallons) by the pump cycle time (in minutes) will give an approximate pump discharge rate (in gpm). Check the observed pump rate against the design requirement for the system, and note any discrepancy.

If during filling of the pump basin, the pump does not activate when the water reaches the high liquid level control (i.e., "ON" float), discontinue the pump test. This indicates a pump failure, defective float switch or wiring problems and will require the repair service of a competent contractor familiar with these types of systems. The pump system failure should be noted, communicated immediately to the resident/owner, and followed up with prompt corrective action.

- b. Dispersal System Inspection. At the completion of the pump test, check the dispersal system area for signs of seepage in the same manner as previously described for gravity-fed systems following hydraulic loading.
- c. Audio and Visual Alarm. Test the pump system audio and visual alarm to confirm that it can be heard at the house/building if mounted at the pump tank.

9. CLEAN-UP

At the completion of the OWTS inspection and testing, replace all access lids and clean all tools before leaving the site. All tools and equipment that come into contact with wastewater should be cleaned and disinfected with a 1:5 bleach solution, then rinsed with fresh water; and all contaminated rinse water should be disposed of in the septic tank.

10. OPTIONAL SOIL BORING.

Ideally, as part of the performance evaluation a hand-augured boring should also be made within or adjacent to the dispersal field for observation of soils and groundwater conditions. If a hand-auger boring is not feasible and the area is known or estimated to have high groundwater conditions, a motorized drill rig or excavator may be necessary. This is especially important if the performance evaluation is in connection with a proposed building remodel or other system expansion. If groundwater is observed in the test hole, measure the depth to water prior to and following the HLT. Backfill the test hole before leaving the site.



SECTION 6

ADVANCED PROTECTION MANAGEMENT PROGRAM

CONTENTS

- A. INTRODUCTION
- B. REQUIREMENTS



SECTION 6 ADVANCED PROTECTION MANAGEMENT PROGRAM

A. INTRODUCTION

According to Section 10.0 of the SWRCB OWTS Policy, an Advanced Protection Management Program is the minimum required management program for all OWTS located near a water body that has been listed as impaired due to nitrogen or pathogen indicators pursuant to Section 303(d) of the Clean Water Act.

Per County Ordinance Article 6, the Advanced Protection Management Program for San Mateo County is intended to apply to new, replacement and expansion OWTS within the following areas:

1. Those lands addressed by a specific TMDL issued by a CRWQCB;
2. Those specific areas as may be determined by the Board of Supervisors as impaired areas based on results of cumulative impact evaluations consistent with the OWTS Code. Such impaired areas may require additional protections related to OWTS design, installation, and reporting (none established as of October 2015); and
3. Those lands within six hundred (600) lineal feet from the natural or levied bank of creeks and rivers, high water for lakes and reservoirs, and the mean high tide line for tidally influenced water bodies, of any impaired water body or segments thereof that are identified by the State Water Board and by US EPA pursuant to Section 303(d) of the Federal Clean Water Act.

Description of all areas considered to be within the Advanced Protection Management Program will be maintained by San Mateo County Environmental Health as part of this Onsite Systems Manual. Maps are provided in at the end of this section for those areas of the County currently designated as “impaired”.

B. REQUIREMENTS

1. For those lands addressed by a specific TMDL, advanced protection management requirements for OWTS will be as defined by the TMDL implementations plan. However, no TMDLs have been completed as of January 2016, that include load allocations for OWTS. For those Impaired Water Bodies that do have an adopted TMDL addressing the impairment, but the TMDL does not assign a load allocation to OWTS, no further action is required unless the TMDL is modified at some point in the future to include actions for OWTS.



2. For those specific impaired areas determined by Environmental Health based on cumulative impact evaluations, any advanced protection management requirements for OWTS will be defined as to mitigate the specific impact(s) (none identified as of January 2016).
3. For those areas within six hundred (600) lineal feet of 303(d) listed water bodies impaired for either pathogens or nitrogen, in the absence of an adopted TMDL, new, replacement and expansion OWTS shall comply with applicable requirements contained in SWRCB OWTS Policy, Section 10, and in this Onsite Systems Manual, including:

- a. Operating Permit Required as Alternative OWTS.

Apply for and maintain an operating permit as an Alternative OWTS, subject to all the requirements of this Manual and County Ordinance 4.84.

- b. Supplemental Treatment for Pathogen Impairment.

- (1) Effluent Quality. For OWTS adjacent to water bodies impaired for pathogens, provide ongoing supplemental treatment for pathogens using supplemental treatment components designed to perform disinfection providing sufficient pretreatment of the wastewater so that effluent from the supplemental treatment components does not exceed a thirty (30)-day average TSS of thirty (30) mg/L and shall further achieve an effluent fecal coliform (or E. coli) bacteria concentration less than or equal to two hundred (200) MPN per one hundred (100) milliliters.
- (2) Groundwater Separation. The minimum soil depth shall not be less than three (3) feet, and the minimum depth to the anticipated highest level of groundwater below the bottom of the dispersal system shall be as defined in County Ordinance 4.84, and Section 3 of this Manual. All dispersal systems shall have at least twelve (12) inches of soil cover.
- (3) Monitoring and Reporting. In addition to all other design, operation, monitoring and reporting requirements of County Ordinance 4.84 and this Onsite Systems Manual, OWTS with required disinfection for pathogens shall be inspected for proper operation quarterly by a service provider while the system is in use unless a telemetric monitoring system is installed capable of continuously assessing the operation of the disinfection system. The wastewater flowing from the supplemental treatment components that perform disinfection shall be sampled quarterly



at a point in the system after the treatment components and prior to the dispersal system and shall be tested for fecal coliform (or E. coli). Reporting of all effluent sample results shall include the geographic coordinates of the sample location. Effluent samples shall be taken by a service provider, using appropriate chain of custody and sample holding and handling techniques, and analyzed by a California Department of Public Health certified laboratory.

c. Supplemental Treatment for Nitrogen Impairment

For OWTS adjacent to a water body impaired for nitrogen, the OWTS must provide ongoing supplemental treatment for nitrogen using supplemental treatment components certified by NSF, or other approved third party tester, to meet a fifty percent (50%) reduction in total nitrogen when comparing the thirty (30)-day average influent to the thirty (30)-day average effluent.



2012 INTEGRATED REPORT — ALL ASSESSED WATERS

Zoom to county:

San Mateo

Zoom to Regional Board:

All

Show county

Show Regional Board

Zoom to water body: (Filter: All)

San Vicente Creek

Filter list by:

Reset list

Map Help

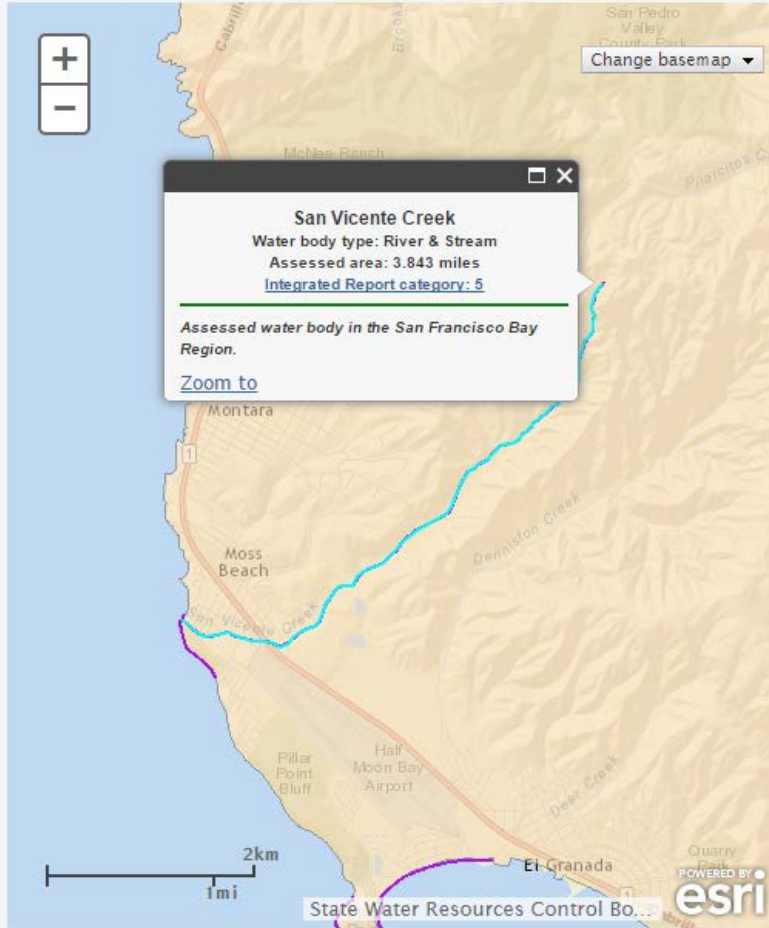

San Vicente Creek Close
 Pollutant assessments

Pollutants	Listing Decision
	Report Link Potential Sources Schedule Comments
Coliform Bacteria	Do Not Delist from 303(d) list (TMDL required list) 18262 n/a Est. TMDL completion: 2019

2012 INTEGRATED REPORT — ALL ASSESSED WATERS

Zoom to county:
San Mateo

Zoom to Regional Board:
All

Show county

Show Regional Board

Map Help

Zoom to water body: (Filter: All)

Pomponio Creek

Filter list by:

Reset list

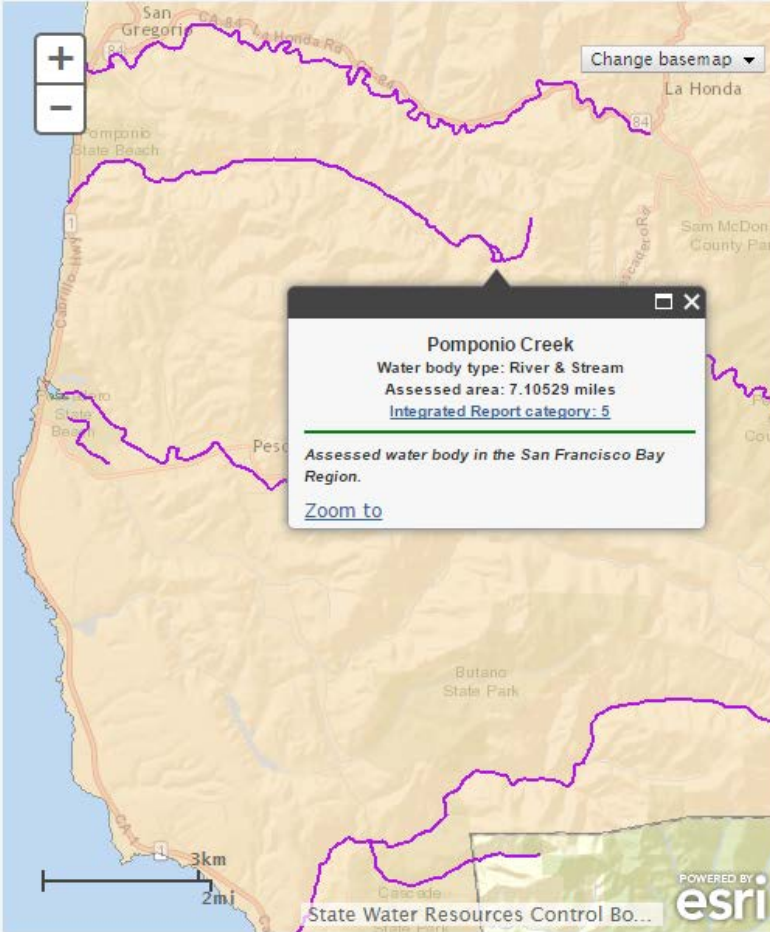

Pomponio Creek
Pollutant assessments

Close

Pollutants	Listing Decision	Report Link	Potential Sources	Schedule	Comments
Coliform Bacteria	List on 303(d) list (TMDL required list)				30355
	n/a				Est. TMDL completion: 2019

2012 INTEGRATED REPORT — ALL ASSESSED WATERS

Zoom to county:
San Mateo

Zoom to Regional Board:
All

Show county

Show Regional Board

Zoom to water body: (Filter: All)

San Gregorio Creek

Filter list by:

Reset list

Map Help

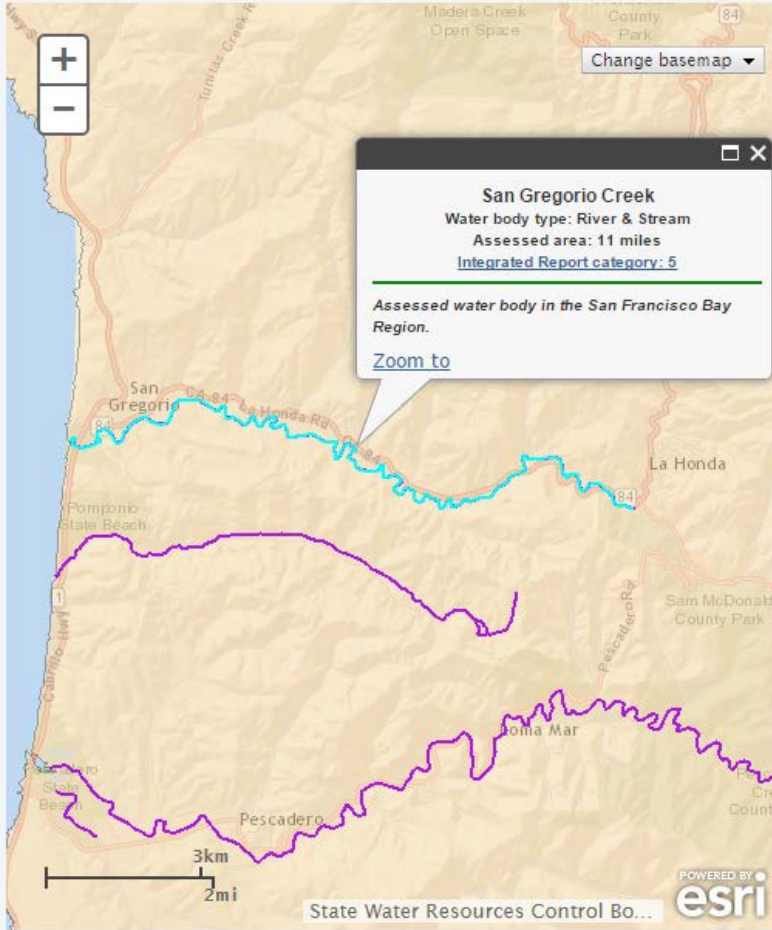

San Gregorio Creek
Water body type: River & Stream
Assessed area: 11 miles
[Integrated Report category: 5](#)

Assessed water body in the San Francisco Bay Region.

[Zoom to](#)

San Gregorio Creek Close

Pollutant assessments

Pollutants	Listing Decision	Report Link	Potential Sources	Schedule	Comments
Cadmium	303(d) list (TMDL required list)	29942	n/a		
Coliform Bacteria	Do Not Delist from 303(d) list (TMDL required list)	18052	n/a	Est. TMDL completion: 2019	
Copper Lead Nickel Silver Zinc	Do Not List on 303(d) list (TMDL required list)	29791	n/a		
Sedimentation/Siltation	List on 303(d) list (TMDL required list)	20017	n/a	Est. TMDL completion: 2013	Impairment to steelhead habitat.