

SAN MATEO COUNTY ENVIRONMENTAL HEALTH DIVISION

SAFE DRUG DISPOSAL

STEWARDSHIP PLAN

PROPOSAL

Resubmittal September 9, 2022



SUBMITTED BY:



Contents

I.	INTRODUCTION	3
II.	CONTACT INFORMATION	4
III.	COLLECTION SYSTEM FOR UNWANTED COVERED DRUGS	8
	A. Convenience.....	8
	B. Kiosk Specifications and Design	11
	C. Mail-Back Envelope Program	14
	D. Safety, Security and Patient Privacy	18
	E. Collector.....	18
	F. Drop Off Sites	18
IV.	HANDLING AND DISPOSAL	19
V.	POLICIES AND PROCEDURES	21
VI.	PUBLIC EDUCATION EFFORT AND PROMOTION STRATEGY	23
	A. Promotion	23
	B. Standardized Instructions	24
	C. Website and Toll-Free Number	25
	D. Educational Materials	27
	E. Public Outreach	27
	F. Biennial Survey.....	29
	G. Language Translation.....	29
	H. Multiple Stewardship Plans	30
VII.	SHORT-TERM AND LONG-TERM GOALS	30
VIII.	ADDITIONAL PLAN CONSIDERATIONS	31
IX.	ADMINISTRATIVE AND OPERATIONAL COSTS AND FEES	31
X.	REPORTING	32
XI.	APPENDIX	33
XII.	APPENDIX A-1: LIST OF CONFIRMED DROP-OFF SITES	34
XIII.	APPENDIX A-2: LIST OF POTENTIAL DROP-OFF SITES	34
XIV.	APPENDIX A-3: LIST OF CONFIRMED MAIL-BACK SITES	35
XVI.	APPENDIX B: PROMOTIONAL SIGNAGE, MAIL-BACK INSERTS AND BROCHURE	37
XVII.	APPENDIX C: TRAINING MATERIAL	43
XVIII.	APPENDIX D: PROMOTION MATERIAL	60
XIX.	APPENDIX E: APPLICABLE PERMITS AND LICENSES	65
XX.	APPENDIX F: COMPLIANCE MATRIX	90

Figures

Figure 1: Kiosk Supply Auto-Replenishment Kit	12
Figure 2: Unwanted Covered Drugs Sample Envelope	15
Figure 3: Inhaler Sample Envelope	16
Figure 4: Sample Auto Injector Container	17
Figure 5: Return Process Tracking	21
Figure 6: Inmar Serialization Tracking Form	22
Figure 7: Call Center Flow	26

I. Introduction

Inmar submits this Stewardship Plan (“Plan”) for Unwanted Drugs in compliance with the San Mateo County Safe Drug Disposal Ordinance numbers 04736 and 4302. (“Ordinance”). All capitalized terms not otherwise defined shall have the same meaning as in the Ordinance.

Inmar’s Stewardship Plan will provide a comprehensive safe drug disposal stewardship program that will include compliant drug collection methods supported by outreach and education programs to increase resident awareness and participation. The Stewardship Plan program will provide safe, secure, and convenient access on an ongoing basis for residents across the county and will be funded by participating covered manufacturers. The program will also provide reporting on collection metrics and results of resident education and outreach campaigns.

Some of the highlights of our plan are as follows.

- **Drug Collection Systems**
 - **Receptacle Service:** Turn-key program with DEA- and DOT-compliant processes and materials
 - **Mail-back Envelopes:** Available by request via a website or toll-free telephone number
- **Education & Outreach:** Strategic deployment of Inmar’s media assets and expertise, as well as far-reaching retail pharmacy relationships, to drive program awareness and participation
- **Annual Reporting:** Insight into required collection and outreach metrics.

II. Contact Information

Ordinance 04736 Section 4.116.040(a)

The following producer(s) have agreed to participate in Inmar's stewardship plan in San Mateo County

:

1. Avet-Heritage Pharmaceuticals, Inc

Jamie Berlanska
VP Chief Financial Officer
1 Tower Center Boulevard, Suite 1700, East Brunswick, NJ 08816
Email: Jamie.Berlanska@avetpharma.com
Phone: 732-429-1000

2. Fosun Pharma USA, Inc

Huong Nguyen
General Counsel
104 Carnegie Center Drive, Suite 204, Princeton, New Jersey 08540
Email: huong.nguyen@fosunpharmausa.com
Phone: 408-200-9891

3. TruPharma, LLC

John E. Mooney
President
4100 W Kennedy Blvd, Suite 220, Tampa, FL 33609
Email: jmooney@trupharma.com
Phone: 312-953-2600

4. Camber Pharmaceuticals, Inc.

Ron Cerminaro
Director, Commercial Strategy and Operations
1031 Centennial Ave., Piscataway, NJ 08854
Email: rcerminaro@camberpharma.com
Phone: 732.529.0430

5. Leading Pharma, LLC

Tal Lev
Chief Financial Officer
3 Oak Rd, Fairfield, NJ 07004
Email: tlev@leadingpharma.com
Phone: 973-276-9600

6. Reese Pharmaceutical Company

Nicholas Green
Pharmaceutical Chemist
10617 Frank Avenue, Cleveland, OH 44106
Email: nick.green@reesechemical.com
Phone: 216-231-6441

7. AAA Pharmaceutical, Inc.

Tejash Sheth
Vice President
681 Main Street Lumberton, NJ 08048
Email: tsheth@aaapharm.com
Phone: 609-288-6060

8. SDI USA, Inc. DBA Simple Diagnostics

Muhammad Arif
President, CEO
5208 Grand Avenue, Maspeth, NY 11378
Email: ma@simplediagnostics.com
Phone: 877-342-2385

9. Bell Pharmaceuticals, Inc

Betty Jo Lorenz
VP, Quality & Regulatory Affairs
200 W. Beaver St. Belle Plaine, MN 56011
Email: Bettyjo@bellpharm.com
Phone: 952-873-2288

10. NextSource Biotechnology, LLC_Tri-Source Pharma

Thomas Hunter
General Counsel, Chief Compliance Officer
80 SW 8th Street, Suite 2660, Miami, FL 33130
Email: tomhunter@trisourceph.com
Phone: 844-696-4667

11. Micro Labs USA, Inc

Gaurang Bhavsar, RAC
Associate Director - Regulatory Affairs
220 Davidson Ave, Suite 402, Somerset, NJ 08873
Email: gaurangbhavsar@microlabs.in
Phone: 908-484-7410

12. Reliable 1 Laboratories, LLC

David Seltzer
CEO
99 West Hawthorne Ave, Suite 610, Valley Stream, NY 11580
Email: david.seltzer@reliable1labs.com
Phone: 516-341-0666

13. Ascend Laboratories

Hindy Schiff
Vice President Regulatory Affairs/Compliance
339 Jefferson Road, Suite 101, Parsippany, NJ 07054 USA
Email: HSchiff@ascendlaboratories.com
Phone: 908.612.3079

14. Dr. Reddy's Laboratories Inc.

Brian Kilmartin
Lead Risk Management PV
107 College Road East, Princeton, NJ 08540
Email: bkilmartin@drreddys.com
Phone: 609-806-3963

15. Hikma Pharmaceuticals USA Inc.

Heather Patrick
Sr. Analyst, Legal Affairs
200 Connell Drive, 4th Floor, Berkeley Heights, NJ 07922
Email: hpatrick@hikma.com
Phone: 908.673.1030

16. Lannett Company Inc.

Michael Gankiewicz
Director DEA & Security
1101 C Avenue West, Seymour, IN 47274
Email: mgankiewicz@lannett.com
Phone: 215-333-9000

17. Noden Pharma USA, Inc

Johanna Sanchez
Senior Supply Chain Manager
233 Mt. Airy Rd, Suite 164, Basking Ridge, NJ 07920, USA
Email: jsanchez@nodenpharma.com
Phone: 908-758-1210

18. Novadoz Pharmaceuticals, LLC

Seshu Akula
President North America Generics
20 DUKE ROAD, SUITE A, PISCATAWAY, NEW JERSEY 08854-3714
Email: seshu.akula@novadozpharma.com
Phone: 908-360-1500

19. Sun (Taro) Pharmaceutical Industries, Inc.

Rick Lewellyn
Assoc. Dir. Supply Chain
2 Independence Way, Princeton, NJ 08540
Email: Richard.lewellyn@taro.com
Phone 914-345-9001

20. Unichem Pharmaceuticals (USA), INC.

Kartik M. Keertikar
Senior Manager, Regulatory Affairs
One Tower Center Boulevard, Suite 2200, East Brunswick, NJ 08816
Email: kkeertikar@unichemusa.com
Phone: 732-253-5954

21. Strides Pharma Inc.

Michael Altamuro
SVP, Sales & Marketing (US)
1 Ram Ridge Rd, Chestnut Ridge, NY 10977
Email: mike.altamuro@stridesusa.com
Phone: 845-682-3251

22. Nivagen Pharmaceuticals

Genevieve Stevens
Operations Director
3050 Fite Circle, Suite 100, Sacramento, CA 95827
Email: gstevens@nivagen.com
Phone: 916-364-1662

23. Prasco Laboratories

Matt Pendley
Sr. Director of Finance
6125 Commerce Court, Mason, OH 45040
Email: m.pendley@prasco.com
Phone: 513-618-3333

24. ProvePharm

Tania Tardif
Office Operations Specialist
100 Springhouse Drive Suite 105, Colleagueville, PA 19426
Email: tania.tardif@provepharm.com
Phone: 610-601-8600

25. Mirum Pharmaceuticals

Mark Jones
Counsel
950 Tower Lane, Suite 1050, Foster City, CA 94404
Email: mark.jones@mirumpharma.com
Phone: 650-667-4085

26. Westminster Pharmaceuticals, LLC

Adrienne Fink
Financial Controller
3450 Buschwood Park Dr, Suite 110, Tampa, FL 33618
Email: finance@wprx.com
Phone: 727-300-1376

For additional questions, contact:

Nick Massaro,
Senior Manager, Consumer Drug Take Back Solutions
1 W. 4th Street
Winston Salem, NC 27101
Email: nicholas.massaro@inmar.com
Phone: 336-770-1992

III. Collection System for Unwanted Covered Drugs

Ordinance 04736 Section 4.116.040(b)

A. Convenience

Ordinance 04736 Section 4.116.050(b)(1)

Ordinance 04736 Section 4.116.050(b)(3)

Inmar will set up a collection system that provides convenient and equitable access to residents across the county as outlined in the Ordinance 04736 Section 4.116.050(b)(1). Drop-off sites are searchable to residents in Google Maps, simply by typing “Drug Disposal,” or other similar phrases in the Google Maps applications.

Pursuant to Ordinance 04736 Section 4.116.050(b)(1) Inmar will seek to establish a minimum of one drop-off site for every 20,000 residents throughout the county, geographically distributed to provide reasonably convenient and equitable access. We will ensure there is never less than five drop-off sites per Supervisorial District, as required by Ordinance 04736 Section 4.116.050(b)(3).

The below charts represent Inmar’s plan to meet the convenience standard described above. The data used comes from the County of San Mateo 2017-2019 Profile from the City Manager’s Office. According to known population data, Inmar will plan to provide a minimum of 51 drop-off sites in the County. Drop off sites will be established across all 5 supervisorial districts and in unincorporated areas based on population. As presented, Inmar will exceed the minimum requirements of 5 drop-off sites per district.

Districts	# of Kiosks (minimum)
District 1 – Dave Pine	10
District 2 – Carole Groom	9
District 3 – Don Horsley	11
District 4 – Warren Slocum	9
District 5 – David Canepa	12
Total	51

City	Population	Supervisorial District	# of Kiosks (minimum)
Atherton	7,167	3	1
Belmont	27,218	2,3	2
Brisbane	4,282	5	1
Burlingame	30,459	1	2
Colma	1571	5	1
Daly City	106,562	5	6
East Palo Alto	29,662	4	2
Foster City	33,477	2	2
Half Moon Bay	12,657	3	1
Hillsborough	11,451	1	1
Menlo Park	33,449	4,3	2
Millbrae	22,795	1	2
Pacifica	39,260	3	2
Portola Valley	4,353	3	1

Redwood City	85,288	4	5
San Bruno	43,185	1,5	3
San Carlos	29,931	3	2
San Mateo	105,536	2	6
South San Francisco	67,271	1,5	4
Woodside	5,561	3	1
Unincorporated	64,000	1,3,4,5	4
San Mateo County Total	765,135		51

Appendix A-1 includes a list of locations confirmed as Authorized Collectors. A-2 includes a list of potential locations which would utilize a kiosk as the collection method upon becoming a Collector. Upon plan approval, the quantity of drop-off sites required will be evaluated and adjusted as Inmar consults with the Department for more detailed information on population centers and areas of need. Inmar will give preference to locating drop-off sites at retail pharmacies and law enforcement agencies (LEAs).

Inmar has identified the following LEAs that do not currently participate as authorized collectors. Upon approval Inmar will make it a priority to reach out and establish drop-off sites at these locations:

Atherton Police Department	83 Ashfield Road, Atherton, CA 94027
Foster City Police Department	1030 E Hillsdale Blvd, Foster City, CA 94404
Colma City Police Department	1199 El Camino Road, Colma, CA 94014

Annually, Inmar will review any potential Authorized Collection locations against the Board of Pharmacy License directory to validate the location holds an active retail, hospital or clinic license. Additionally, sites will be required to provide evidence of current DEA registration. Inmar will notify the Director as new Authorized Collection Sites become operational. Such notification will include the Authorized Collector's contact information.

Inmar will establish mail-back distribution locations to supplement service in any area underserved by collection sites. Inmar currently has Rx Returns clients in San Mateo County, of which many are retail pharmacy clients. Inmar will evaluate and contact these retail pharmacies as potential collection sites or mail-back distribution sites as needed. Inmar will utilize hospitals with on-site pharmacies and law enforcement agencies as necessary to meet the goals of equitable and reasonably convenient access for residents across San Mateo County. However, it is our expectation that the majority of authorized collection sites will be retail pharmacies. Appendix A-3 represents a list of confirmed mail-back distribution locations. Appendix A-4 represents a list of potential mail-back distribution locations.

It is Inmar's intention not to duplicate any locations for kiosk placement with existing plan operators. If necessary and upon plan approval, Inmar will coordinate with existing plan operators on how to manage a kiosk at the same location. Inmar will not approach any currently operating sites for a minimum of three months after plan approval.

The below maps represent coverage of San Mateo County, upon plan approval, by the current list of confirmed Authorized Collection locations. Each map includes both Drop-off Sites as well as Mail-back Sites. The maps serve to demonstrate coverage at both a 5 mile radius and 15 mile radius from the Authorized Collection locations.

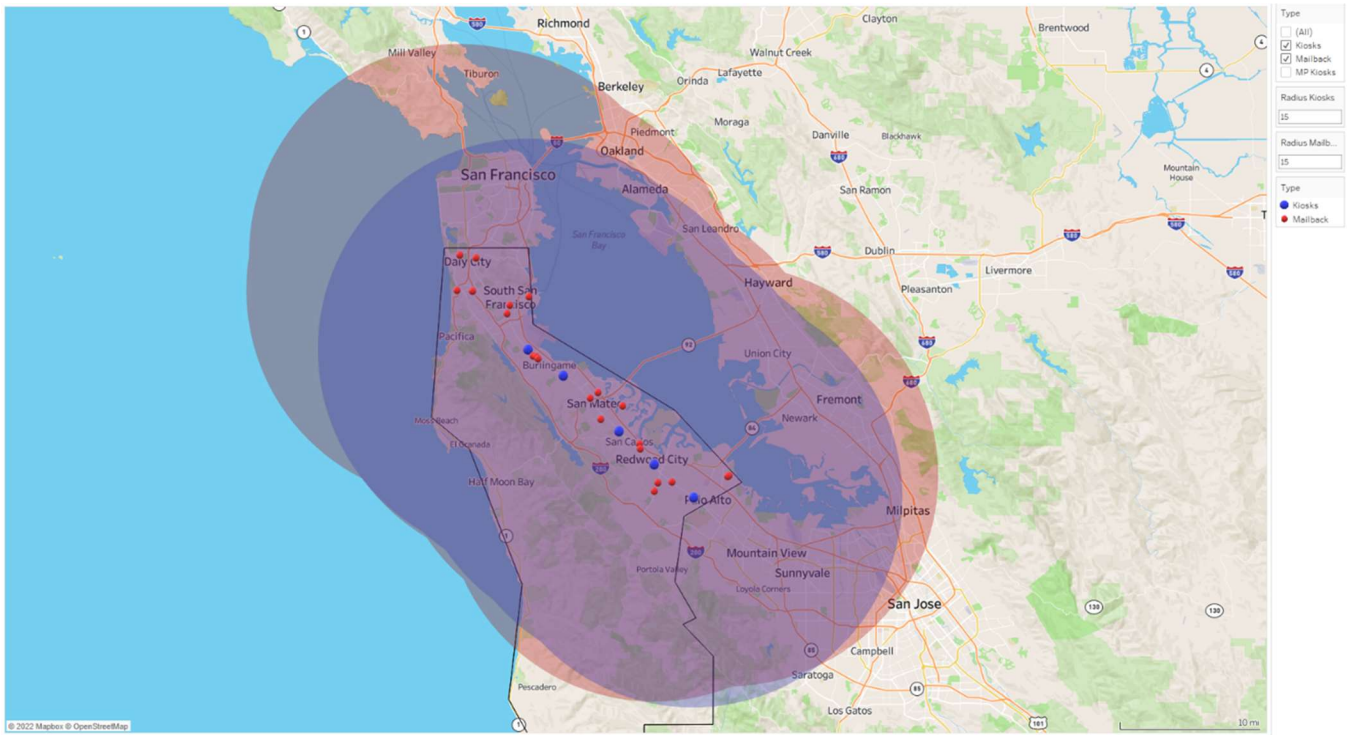
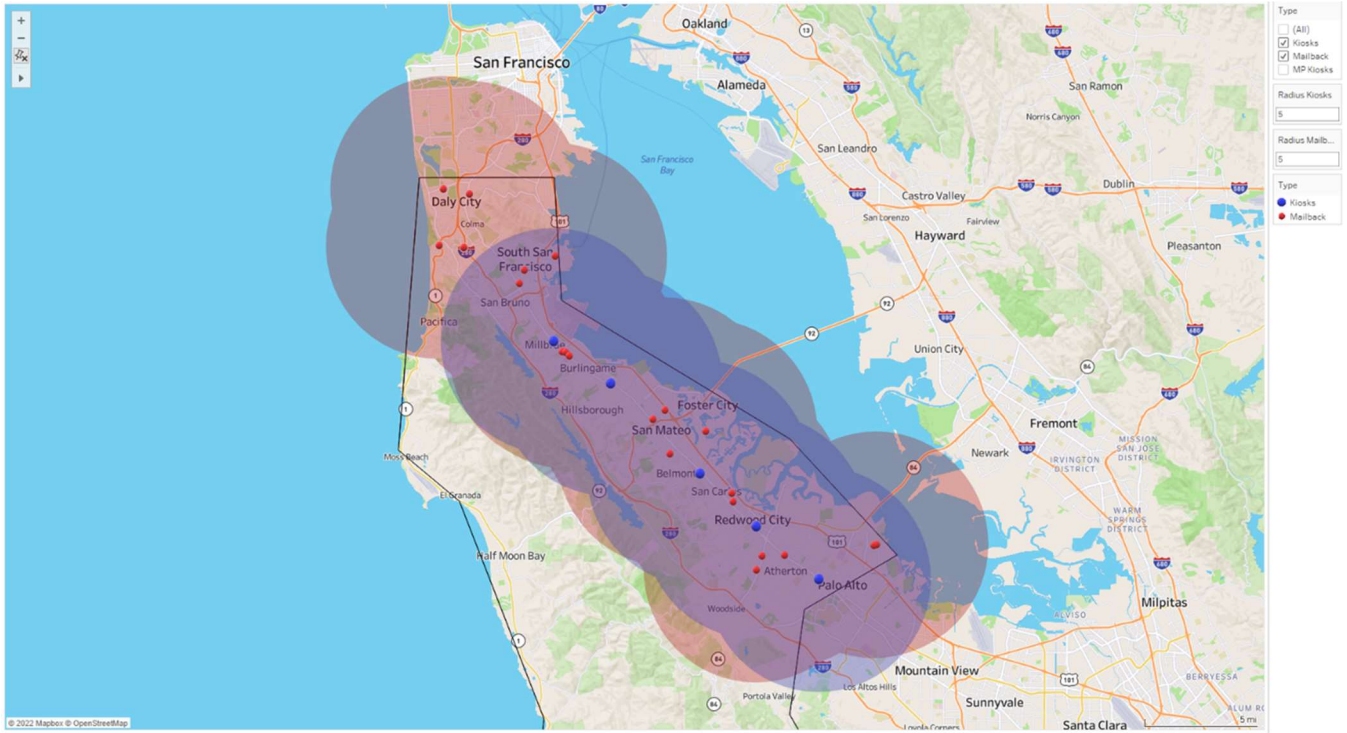

B. Kiosk Specifications and Design

Ordinance 04736 Section 4.116.040(b)

Ordinance 04736 Section 4.116.050(d)

Inmar's kiosk is made in the USA and designed for excellence. Produced from 16 gauge cold-rolled steel, and with an easy-to-use, Americans with Disabilities Act (ADA)-compliant drop-box design, residents can easily drop unused medications through the drop door and into the shippable container with inner liner inside. The container is a 275lb rated box with a 6 mil, DEA-compliant liner.

There are several unique features that enhance the effectiveness and security of the Inmar kiosk. For example, the top of the kiosk is sloped, limiting the ability to stack items on top. In addition, the drop slot features an extended metal drop door that lowers into the container to detect when product capacity is reached. When the drop door encounters resistance within the kiosk, it is an indication that it is time to change the container. This manual capacity indicator eliminates the need to change batteries and/or sacrifice the location of the kiosk to be in proximity to an electrical outlet. Lastly, the container access door is reversible to allow for convenient placement in any appropriate location in the pharmacy.

Per DEA requirements, the kiosk must be installed in the line of sight of the pharmacy and bolted to the floor or a permanent fixture. The Inmar kiosk has pre-drilled holes in the bottom for easier installation. It also features a 4-point locking system with steel projections in two center locations and the top and bottom of the door that are activated when locked for strengthened security. Top and bottom deadbolt locations are hidden from the outside to prevent break-ins.

The Inmar kiosk will have signage that communicates what is and is not allowed to be placed inside. The signage will also feature a website and toll-free telephone number so users of the program can ask questions and find more information. Inmar will work with the Environmental Health Division of the County of San Mateo to design signage that meets the needs and requirements of the program. See Appendix B for examples of signage.

Inmar's DEA- and ADA-compliant kiosk is sent to the authorized collector along with enough supplies for 3 returns. Supplies include:

- Pre-addressed, pre-paid serialized containers
- Serialized inner liners to protect against puncture and provide a liquid barrier
- Easy-to-use, serialized zip ties to seal each inner liner compliantly
- Absorbent pad for placement in the bottom of the inner liner bag

Pick-Up and Disposal

For the safe on-site removal of contents and servicing of drug take-back kiosks, Inmar abides by the DEA regulations in 21 CFR 1300 et al.

Inmar will work with each authorized collector to develop a collection program schedule that works specifically for their location - either an on-site or self-service option as outlined below.

With either of the service models outlined below, the focus will be on each authorized collector to develop a program that works specifically for their location.

A support help desk will also be established that will assist the authorized collectors with set-up, administration and operation of the kiosk at the collection sites.

Standard Self-Service Returns

Inmar will train authorized collectors to service the containers on their own to allow for expedited servicing as desired. The steps to service a container are fast, efficient, and DEA-compliant. Inmar will provide authorized collectors with training materials including step-by-step instructions for tracking, sealing, replacing, and shipping collection containers. See attached Steps to Start, FAQs, and Installation Instructions provided Appendix C.

Optional On-Site Pick-Up Service

Inmar may offer on-site service for the collection, replacement, and shipping of full containers. On-site service will be provided by a qualified service representative. To remain compliant with the DEA, the authorized collector will need two employees to oversee the service process with the kiosk.

Auto-Replenishment of Kiosk Supplies

Auto-replenishment of the supplies needed to collect and transport returned medications is provided in “kits” of three. Each kit includes: pre-labeled and pre-paid cardboard box containers, liquid barriers, and serialized, puncture-resistant inner liners. Upon receipt of the second return within the kit, Inmar automatically ships another kit with a set of three containers/supplies. This auto-replenishment reduces the amount of inventory maintained at the collection site while maintaining sufficient replacement supplies to keep the kiosk continuously operable.



Figure 1: Kiosk Supply Auto-Replenishment Kit

Optional On-Site Pick-Up Service

Inmar will offer on-site service for the collection, replacement and shipping of full containers. This all-inclusive program removes the burden for the authorized collector and the pharmacy staff.

Inmar will initiate standard service intervals for each collection site. Once a pattern of usage has been established, the service schedule will be adjusted with the agreement of the authorized collector to provide the best overall service with minimal interruption.

Inmar will work with the authorized collector to adjust the schedule based on utilization of the receptacle.

The “Pre-Scheduled Service Event” will include:

- Observation of the condition of the receptacle upon arrival
- Notification to the pharmacy personnel of arrival
- Coordination of 2 pharmacy employees to witness change out of receptacle supplies
- Removal, packaging, and documentation of the container from the receptacle
- Replenishment of new supplies for renewed operation
- General clean-up and wipe down of receptacle
- Notation of container serial number removed, and serial number installed along with signatures by 2 pharmacy employees (witnesses)
- Removal of full container to be placed behind the pharmacy counter to await FedEx pick up.
- Final signature from pharmacy personnel of completion of Service Event.

Regardless of the service model selected, Inmar has a long standing contractual relationship with FedEx and therefore has multiple internal and external contacts. Inmar’s procurement and operations teams have direct relationships with personnel at FedEx corporate office. Should an issue arise with the standard 48 hour service level agreement, these contacts will be leveraged daily for mitigation of further issues as well as any needed general support. Detailed FedEx contact information can be found in Section IV.

Inmar will periodically monitor all container FedEx shipment tracking numbers from pharmacy locations to the designated reverse distributor as designated in Section IV.

Our training with both the retail pharmacy technicians and Inmar technicians include documentation which details the steps required to schedule FedEx pickups of the full containers. Inmar conveys this training both in written and oral format.

For locations where Inmar technicians aren’t regularly servicing kiosks, Inmar has established several processes for issues to be mitigated. Aside from visual inspection when locking and unlocking the kiosk for use during pharmacy hours, pharmacy staff are provided with the following resources should they experience issues with the kiosk:

- Email the take-back@inmar.com inbox which is monitored by a large team of full time workers and issues can be quickly triaged and handled.

Inmar has a team of full time staff members dedicated to the program that will regularly visit kiosk locations to review and audit locations for program compliance.

C. Mail-Back Envelope Program

Ordinance 04736 Section 4.116.050(b)(5)

As required by Ordinance 04736 Section 4.116.050(b)(5), Inmar will provide prepaid and pre-addressed take-back return envelopes, free of charge, to all residents including disabled or homebound County residents. Mail-back envelopes will be provided at mail-back distribution location sites, and will also be available directly from Inmar via the program website and toll-free 800 number.

Inmar will offer Mail-back services at multiple retail locations throughout the County. In locations where Inmar needs to offer Mail-back services locations to supplement the requirements for the convenience standard, our plan is simple and easily repeated. Unless otherwise requested by Authorized Collector kiosk locations, we will distribute Mail-back services envelopes only at locations that are non-kiosk locations.

Once a location has been accepted as a Mail-back services location, Inmar will send a stack of prepaid, pre-addressed Unwanted Covered Drugs Mailers to that location as a Mail-Back Starter Kit. Mailers will accept all Unwanted Covered Drugs, including pills, creams and liquids, and schedule II-V controlled substances. However, inhalers and auto-injectors will require the use of different mailback packages (described below) and will not be included in the Starter Kit. The Starter Kit will include 20 Mailers sent to each location. Inmar will track the unique identifier for all Mailers sent to each location for fulfillment and logistical purposes. Inmar will add a visual reorder trigger in the box of emailers. Once the location gets to the reorder trigger in the box, the visual reorder trigger will instruct the location to email Inmar for another kit. This service model ensures that there is no 'down time' at the site for mailers. If a location begins to use a larger number of Mailers, the number of fulfilled envelopes sent to that location will be increased.

Inmar is committed to providing all pharmacies an option to supply their customers with information regarding Mail-Back service options. Inmar will provide pharmacies with small cards that can be handed out to County residents that may need access to this service. The card will instruct them to either call or visit the program website to locate the nearest kiosk or request a mailer. Additionally, we will reach out to pharmacies filling prescriptions by mail to include the cards for the same options.

Additionally, County Residents will be able to request one Unwanted Covered Drug Envelope at a time via the Plan website or toll-free number. County Residents will receive the Unwanted Covered Drug Envelope no later than 10 business days from the date of request.

Both the Unwanted Covered Drugs and Inhaler Envelopes will meet DEA rule requirements under § 1317.70(c):

- Preaddressed, postage paid
- Nondescript, and do not indicate what may be inside
- Waterproof, tamper-evident, tear-resistant, and sealable
- Contain a unique ID number that allows for tracking
- Include instructions for the user that indicate the process for mailing the package, substances that can be sent, notice that packages can only be mailed in the US customs territory, and notice that the only packages provided by the authorized collector will be accepted
- No personally-identifiable information will be required

Both Envelopes are white in color with a gray interior and are 7” x 10”. The Envelopes include a 3” perforated lip security seal. They are distributed by our third party contractor 123 Compliant Logistics, Inc.

A sample envelope is shown below.

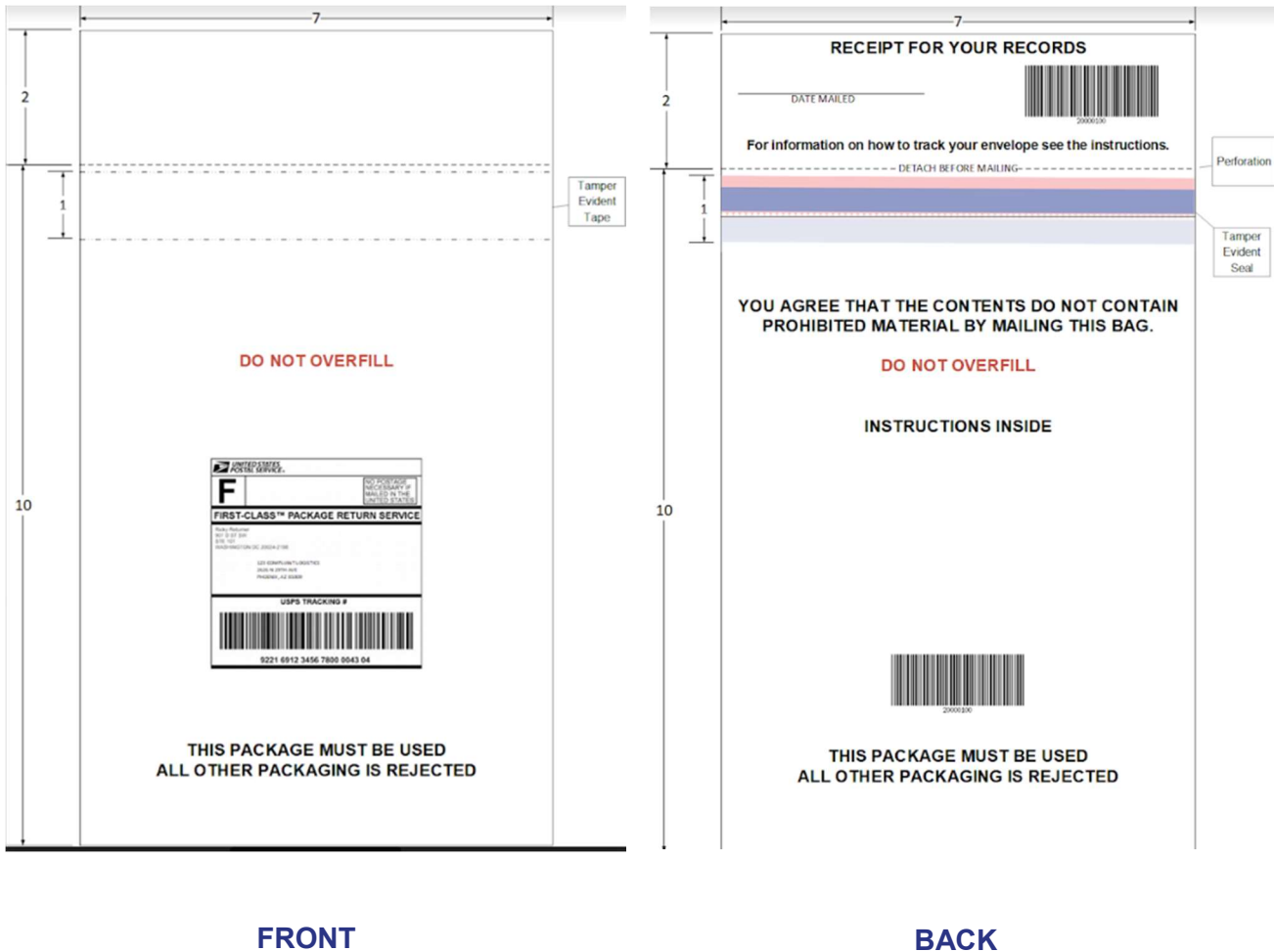

Figure 2: Unwanted Covered Drugs Sample Envelope

Sample Inhaler Envelope

County Residents will be able to request one Inhaler Envelope at a time via the Plan website or toll-free number. County Residents will receive the Inhaler Envelopes no later than 10 business days from date of request.

A sample inhaler envelope is shown below:

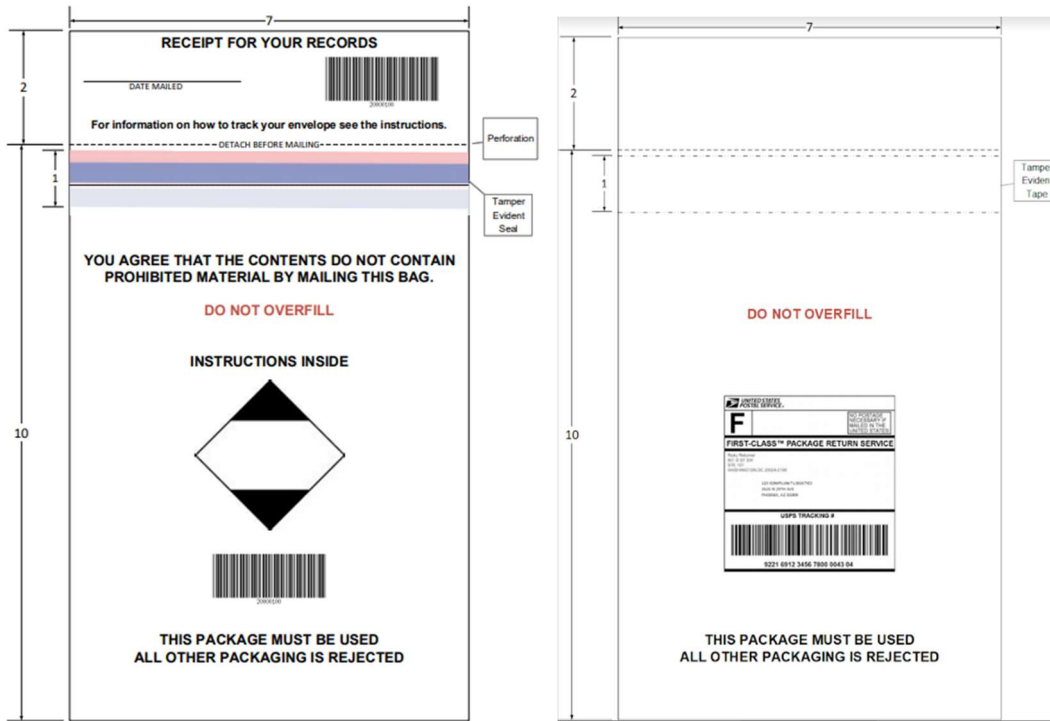

Figure 3: Inhaler Sample Envelope

Sample Auto Injector Container

County Residents will also be able request one auto-injector Mail-back container at a time via the Plan website or toll-free number. County Residents will receive the auto-injector Mail-back container no later than 10 business days from the date of request. Auto-injector containers will meet all DOT requirements and will be fulfilled by 123 Compliant Logistics, LLC, or other Service Providers as listed. See below for specifications and sample.

Specifications	
Access	Petals
Dimensions (in.)	7.5 x 3.6 x 3.6 in.
Color	Red
Lid Type	Hinge Cap
Liquid Absorbing Pad	Product has liquid absorbing pad
Universal Biohaz Sym	Product has universal biohaz symbol
Volume (L)	1.4 qt



Figure 4: Sample Auto Injector Container

Mail-Back Instructions

Mail-back instructions to County residents for all types of mailers are provided in Appendix B.

Mail-Back Envelope Tracking

Mail-back envelopes distributed by authorized mail-back distributors will be tracked in a method similar to the kiosk collection containers. Mail-back envelopes will have a unique, serialized identification number. When envelopes are distributed to consumers requesting them, the authorized collector employee will make note of this event on a serialization tracking sheet. Once the envelope arrives at the destruction facility, the serial number will be noted before final disposition.

Mail-back envelopes distributed directly to consumers via request from the website or toll-free telephone number will be tracked by Inmar when sent to consumers and tracked at the destruction facility when they are returned.

This tracking process will allow Inmar to report the number of mail-back envelopes distributed and returned in the Annual Reporting provided to the Department, as required.

D. Safety, Security and Patient Privacy

Ordinance 04736 Section 4.116.040(e)

Ordinance 04736 Section 4.116.050(b)(2)

Inmar provides significant training to our participating authorized collectors and strictly follows the DEA guidelines for the proper handling of the take-back kiosks and inner liners. This begins with the proper training of the authorized collector in the compliant operation of the kiosks and proper preparation, removal, and packaging of the container. It also involves the training of the Inmar staff that may come into contact with the full container to ensure proper handling. Inmar is very strict in our compliance to the DEA guidelines.

According to the DEA - As provided in §§ 1317.60(c) and 1317.70(f), inner liners shall be sealed immediately upon removal from the permanent outer container; sealed inner liners and returned mail-back packages shall not be opened, x-rayed, analyzed, or otherwise penetrated. Accordingly, their contents shall not be sorted or inventoried subsequent to being placed into a collection receptacle or mail-back package. To clarify this, § 1317.75(c) was modified to add the prohibition against individually handling substances after they have been deposited into a collection receptacle.

Inmar has a long history of serving both commercial and government clients with stringent program requirements. For example, Inmar's pharmacy applications manage Protected Healthcare Information (PHI) and are HIPAA compliant. Additionally, as part of Inmar's Rx Returns (reverse distribution) business, we work very closely with regulators to implement compliant procedures covering the DEA, Boards of Pharmacy, EPA, and other tangential regulatory entities. Data protection, privacy and adherence to applicable regulations are the foundation of Inmar service capabilities.

Any and all patient information on drug packaging and mail-back envelopes will be promptly destroyed.



Inmar has a long history of serving both commercial and government clients with stringent compliance standards such as the protection of Protected Health Information (PHI) and HIPAA.

E. Collector

Ordinance 04736 Section 4.116.050(b)(3)

Ordinance 04736 Section 4.116.050(b)(4)

Inmar will give preference to Retail Pharmacies and law enforcement agencies as drop-off sites and will ensure they are able to meet the requirements within three months of their offer to participate. Appendix A includes a list of potential locations which would utilize a kiosk as the collection method upon becoming a Collector. Inmar can also provide drop-off sites at hospital locations.

F. Drop Off Sites

Ordinance 04736 Section 4.116.050(b)(4)

Ordinance 04736 Section 4.116.050(c-d)

Pursuant to Ordinance 04736 Section 4.116.050(d) Inmar will accept covered drugs from residents during all hours that the retail pharmacy, law enforcement agency, or other authorized collector is normally open for business.

All drop-off sites will utilize secure kiosks as described in section (d). Per DEA requirements, the kiosk must be installed in the line of sight of the pharmacy and bolted to the floor or a permanent fixture. The Inmar kiosk has pre-drilled holes in the bottom for easier installation. It also features a 4-point locking system with steel projections in two center locations and the top and bottom of the door that are activated when locked for strengthened security. Top and bottom deadbolt locations are hidden from the outside to prevent break-ins.

In the unlikely event that more than one stewardship plan operates a drop-off site at a particular location, Inmar agrees that each drop-off site will accept all Covered Drugs. Additionally, in compliance with Ordinance 04736 Section 4.116.050(c), Inmar will operate a drop-off site within each county-owned pharmacy, either independently or in collaboration with other stewardship plans.

IV. Handling and Disposal

Ordinance 04736 Section 4.116.040(c)

Ordinance 04736 Section 4.116.070

Kiosk containers will be sent using Inmar's DOT Special Permit #20499, from the authorized Collector via FedEx to Inmar's third party contractor, 123 Compliant Logistics, LLC, a licensed DEA Reverse Distributor-Collector. Inmar has secured backup Service Providers as listed on the table below which may be used to provide these services. All mailers will be sent via USPS to 123 Compliant Logistics. 123 Compliant Logistics will record the following information upon receipt of every individual container and mailer:

- Date received
- Serialized barcode label information
- Tracking information (Kiosk containers only)
- Weight
- Date transported to disposal facility
- Disposal Date
- Manifest number (if applicable)

All information recorded will be transferred back to Inmar on a daily basis as part of the electronic raw data file via SSH File Transfer Protocol (SFTP). Any discrepancies observed at 123 Compliant Logistics will be recorded on discrepancy reports to prompt any corrective action.

123 Compliant Logistics operates in full compliance with DEA § 1317.75(c) which prohibits handling substances after they have been deposited into a collection kiosk.

All product shipped directly to 123 Compliant Logistics will be transported using their contracted, licensed hazardous waste transporter, TransChem Environmental to the appropriate disposal facility to be incinerated quickly, securely, efficiently and in accordance with all DEA requirements. 123 Compliant

Logistics will be responsible for all DEA Form 41 record keeping requirements. Please refer to the table below for the contracted disposal locations.

In reference to Ordinance 04736 Section 4.116.070(a), 123 Compliance Logistics, TransChem Environmental and FedEx will comply with all local, state and federal laws and regulations surrounding the transportation and disposal of Unwanted Covered Drugs. Additionally, service related to the collection, transport and disposal of unwanted medicine will be provided to authorized collectors and residents at no cost. Contact information and registration information is listed in the table below.

Company Name	Contact Information	Registration Information	Type of Service
123 Compliant Logistics, LLC 2626 N 29th Ave Phoenix, AZ 85009	Rory Buske 602-612-4140	DEA Reverse Distributor-Collector: R90571264	Reverse Distributor – Kiosk Containers
Indianapolis Resource Recovery Facility in Indiana, operating as Covanta Indianapolis, Inc. 2329 S. Harding Street Indianapolis, IN 46221	Alex Davila 317-478-0670	DEA Reverse Distributor-Collector RC0620496 EPA ID No: IND984882365	Reverse Distributor – All Covered Drugs (Mail-back Packages & Packaged Containers from Authorized Collectors)
Covanta Manheim dba Chesapeake Waste Solutions 190 Shellyland Rd, Manheim PA 17545	Ken Wilson 717-653-8882	DEA Registration No. RC0322595	Reverse Distributor – All Covered Drugs (Mail-back Packages & Packaged Containers from Authorized Collectors)
Curtis Bay Medical Waste Services 3200 Hawkins Point Road, Baltimore City, MD 21226	Sam Blanchard (855) 228-1715	US EPA ID No. MDD985404318	Hazardous Waste Incinerator Covered Drugs-Kiosks & Mailers
Ross Incineration Services 36790 Giles Road, Grafton, OH 44044	Chris Fada 440-748-5800	EPA ID No. OHD048415665	Hazardous Waste Incinerator Covered Drugs-Kiosks & Mailers
Clean Harbors Aragonite 11600N. Aptus Rd. Aragonite, UT94029	Michael Marlow 435-884-8100	EPA ID: UTD981552177	Hazardous Waste Incinerator Covered Drugs - Kiosks & Mailers
Clean Harbors El Dorado, LLC 309 American Circle El Dorado, AR 71730	Dan Roblee 870-863-7173	EPA ID: ARD069748192	Hazardous Waste Incinerator Covered Drugs - Kiosks & all Mail-back packages
Veolia ES Technical Solutions, L.L.C 7665 Highway 73 Port Aurthur, TX 77640	David Michaelis 281-216-9618	EPA ID: TXD000838896	Hazardous Waste Incinerator Covered Drugs – Kiosks & all Mail-back packages
TransChem Environmental 542 East 27 th Street Tucson, AZ 85713	520-829-5651	DOT Registration: 052119550060B Hazardous Materials Safety Permit: US-1341480-AZ-HMSP	Hazardous Waste Transporter
FedEx	Eric Stillson 800-469-9993		Common Carrier – Kiosk Containers
USPS	Jackie Purcell 919-501-9394		Common Carrier – All Mail-back packages

V. Policies and Procedures

Ordinance 04736 Section 4.116.040(d)

Inmar operates drug take-back kiosks across 49 States and the District of Columbia as part of its operations today and maintains compliance with all federal and state laws and regulations. Upon approval to act as a “Stewardship Organization,” Inmar will ensure that it acts in compliance with all applicable laws, rules, and regulations as specified by the program requirements and require by contract where applicable that vendors and drop-off sites are also compliant with all laws, regulations, and legal requirements.

Inmar, drop-off sites, and vendors will specifically be required to comply with The Controlled Substances Act, 21 USC SS 801-971 and 21 CFR SS 1317; United States Department of Transportation Hazardous Materials Regulation, 49 CFR parts 100-185; All applicable San Mateo County Rules and Regulations.

The DEA Rule defines authorized collectors as law enforcement agencies and additionally as retail pharmacies, reverse distributors, hospitals or clinics with onsite pharmacies and certain other entities that are registered with DEA as an authorized collector.

Inmar requires a signed agreement with retail locations ensuring their commitment to compliant operation of the Take-Back kiosk and shipping of contents in compliance to the DEA regulations. A refusal to sign the agreement or comply with the DEA regulations would be a reason why a retailer could be excluded from the San Mateo County Stewardship Plan.

Documentation and Tracking

Collection containers and inner liners will have a serialized identification number to enable tracking at all stages of the return process illustrated below.

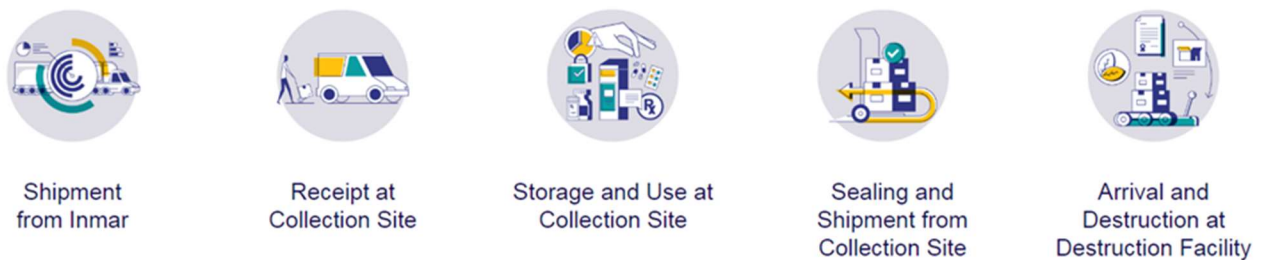

Figure 5: Return Process Tracking

Kiosk tracking is well-documented as evidenced by the Inmar serialization tracking form that is included in full as Appendix C and referenced below. This form must be completed and witnessed by two authorized collection site employees, which assures compliance and safety across the program, and internally by both the stewardship organization and the authorized collector.

 DRUG DISPOSAL SERIALIZATION TRACKING SHEET INNER LINER TRACKING FORM							
Serialization Tracking Sheet should be validated by 2 pharmacy employees.							
Name of Collecting Pharmacy		Address of Collecting Pharmacy			Collecting Pharmacy DEA #:		
SERIAL NUMBERS	Date Received by (1 Signatures)	Date In Use (2 Signatures)	Date Removed (2 Signatures)	Date Shipped (2 Signatures)	Size of Liner	Address of Reverse Distributor/Disposal Site	Reverse Distributor/Disposal Site DEA #
Ex: 32587	4/26/19 John Jones	4/26/19 John Jones Sally Smith	5/26/19 John Jones Sally Smith	5/27/19 John Jones Sally Smith	Ex: 18 Gallon	1515 S Holt Road Indianapolis, IN 46241	Ex: 123456

Figure 6: Inmar Serialization Tracking Form

The purpose of this form is to document the use of the serialized inner liner throughout the collection process and to help the authorized collector meet record-keeping requirements. Inmar will require each authorized collector to understand and comply with all federal, state, and local regulatory requirements pertaining to take-back pharmaceuticals applicable at the authorized collector's registered location.

The serial numbers, date received, and signatures of the authorized pharmacy employees must be completed upon receipt of the container and inner liner. As illustrated above, the date-in-use is to be completed with authorized pharmacy employee signatures upon installation of the kiosk. The date the container and inner liner are removed from the kiosk is also to be noted with signatures. Finally, the date the container and inner liner are shipped is to be noted with authorized signatures.

Authorized collectors must maintain a copy of the completed form, and other records as applicable, on file at the authorized collector's registered location for at least three years.

Mail-back packages are sent via USPS to 123 Compliant Logistics or alternative Service Provider. County residents utilizing mail-back services place their unwanted or expired medication inside the envelope or auto-injector container, remove the perforated portion (which contains the tracking ID for the main package) and mail the package. While in transit, the ultimate user can track the package to ensure that it has arrived at 123 Compliant Logistics.

County residents can track their own packages, and should they notice any issues, they can contact Inmar Intelligence to indicate that their package was lost in transit. Inmar Intelligence will also periodically monitor mail-back packages being sent via USPS to 123 Compliant Logistics for potential issues. If any issues are identified, Inmar will immediately notify 123 Compliant Logistics and begin to leverage our partnerships with USPS to initiate an investigation. Findings from any incidents of USPS mail-back issues will be provided in the annual report.

Transport

The authorized collector will properly seal, store securely, and arrange for pickup of the sealed inner liner and its contents from the registered location in a manner consistent with DEA regulations. The container will include a pre-addressed and prepaid shipping label. The common carrier representative will take possession of the liner and deliver the liner to an approved destruction facility for witnessed incineration.

Disposal

Once the container/inner liner arrives at the destruction facility, the serial number will be noted before final disposition.

This tracking process will allow Inmar to report the number of collection site containers/inner liners distributed and returned in the reporting provided to San Mateo County, as required.

Compliance with Applicable Laws

Inmar operates across 49 states and the District of Columbia and maintains compliance with all federal and state rules and laws. Upon approval to act as a “Stewardship Organization,” Inmar will ensure that it acts in compliance with all applicable laws, rules, and regulations as specified by the program requirements and require by contract where applicable that vendors and collection sites are also compliant with all laws, regulations and legal requirements.

Inmar’s drug kiosks are DEA- and ADA-compliant and provide environmental protection from unwanted drug residue. The units are equipped with a four-point locking system with hidden steel deadbolts that are activated when locked for strengthened security. They contain pre-drilled holes at the bottom of the unit for easy installation to securely bolt them to the floor in each approved collection site. The internal container and supplies protect against puncture and provide a liquid barrier to prevent seepage and/or spillage.

Inmar’s Training Materials, found in Appendix C, aid collection sites in proper drug kiosk installation, which helps optimize the security of the unit. The Training Materials also include information on receptacle operation, inner container materials assembly and placement, regulated shipping instructions, program FAQs, and serialization tracking. All of these inclusions maximize the safety and security of any person involved in the program at the collector level.

VI. Public Education Effort and Promotion Strategy

Ordinance 04736 Section 4.116.040(f)

Ordinance 04736 Section 4.116.060

A. Promotion

Ordinance 04736 Section 4.116.060(a)(1)

Inmar will execute a comprehensive and measurable public outreach strategy to drive awareness of the drug take-back program and maximize participation as required by Section 4.116.060 of the San Mateo County Safe Drug Disposal Ordinance. In addition to preventative education, Inmar’s strategy is designed to ensure that where and how to return covered drugs is widely understood by residents, pharmacists, retail pharmacies, health care facilities and providers, veterinarians, and veterinary hospitals. It is Inmar’s goal to reach a 75% saturation rate after 3 years for promotion of San Mateo County’s population. This will be measured by a question in the biennial survey which requests

participants to identify whether certain promotional activities have reached them.

A leader in the promotions space for nearly 40 years, Inmar has a unique set of core capabilities relative to other prospective program operators, specifically in consumer marketing and activation. Thus, in addition to traditional outreach methods (signage, written materials, etc.), Inmar is able to drive participation among covered entities with modern, high-impact tactics such as influencer marketing and targeted media.

The individual components of Inmar’s public outreach strategy are detailed below. Across all tactics, key messages will include, but not be limited to, the following:

- Encourage safe storage of drugs in the home (especially around children and teens)
- Dangers of drug misuse (i.e., not taking medicines as prescribed)
- Discourage improper disposal of drugs (e.g., flushing or solid waste collection)
- Arrival of a safe drug take-back solution with instructions for how to locate and participate
- Consumer Drug Take-Back Day promotion

If more than one drug take-back program is approved by the department, Inmar will seek to coordinate its promotional activities with other approved programs within 6 months after the other program is approved. Inmar’s LifeInCheck™ Consumer Drug Take-Back website will ensure that all covered entities can easily identify, understand, and access the collection services provided by Inmar and other program operators. Upon plan approval coordination efforts with existing plan operators will include providing a single website and toll-free telephone number to access information about collection services for all approved programs.

B. Standardized Instructions

Ordinance 04736 Section 4.116.060(a)(2)

As required in the Ordinance 04736 Section 4.116.060(a)(2), Inmar will coordinate with the existing approved Stewardship Plan operator to coordinate and develop a single system of promotion to include standardized instructions for County Residents. Additionally, Inmar provides authorized collectors with easy to understand and standardized instructions explaining how to use the collection kiosk. The educational materials will be distributed to audiences such as LEAs, pharmacies, healthcare providers and systems, local government agencies and community organizations. Materials and outreach channels include:

1. Website and toll-free number
2. Educational Materials
 - i. Educational brochure for residents
 1. Including information on what types of unwanted medicine including inhalers and auto-injectors is accepted
 - ii. Training materials for authorized collectors
 1. Container Instructions
 2. Steps to Start Document
 3. Installation Reference Guide
 4. Serialization Tracker
3. Public Outreach

Educational materials for residents are provided in Appendix B. Training material samples are provided in Appendix C.

Collection Receptacle Signage

The collection receptacles themselves will be readily recognizable. Inmar will coordinate with the existing approved Stewardship Plan operator as part of the single system of promotion to ensure that the collection receptacles are readily-recognizable. Each receptacle is adorned with clear graphical instructions in English, Spanish, Chinese and Tagalog for proper use. Please see Appendix B for an image of the collection receptacle and disposal instructions.

C. Website and Toll-Free Number

Ordinance 04736 Section 4.116.060(a)(3)

Website

The current County approved Stewardship Plan Operator operates the website Medproject.org. Inmar agrees to use the existing website in coordination with any other approved Stewardship Plan Operator(s). Upon approval, Inmar is committed to working with any approved Stewardship Plan Operator(s) as required to determine a fair and equitable method in jointly meeting the requirements under the Ordinance. Such coordination will be complete within 6 months of approval of the Plan.

Alternatively, Inmar can provide a mobile-optimized website, appropriately translated into English, Spanish, Chinese and Tagalog, which will publicize collection options and educate covered entities on proper disposal practices. Inmar will use enhanced search engine optimization to ensure easy location and access.

Specifically, the website would:

- Leverage Inmar's collaboration with Google Maps to allow covered entities to find the nearest collection site or mail-back distribution site via an interactive map. The list of locations will be updated monthly to ensure accuracy.
- Allow covered entities to request prepaid return envelopes.
- Feature links to LifeInCheck™ social media pages for more useful content.

Retailers or pharmacies interested in participating in the drug take-back program will be able to request more information through the website.

Toll-Free Number

The current County approved Plan Operator operates the toll-free number 844-633-7765 in the required languages. Inmar agrees to use the existing toll-free number in coordination with any other approved Plan Operator(s). Upon approval, Inmar is committed to working with any approved Stewardship Plan Operator(s) as required to determine a fair and equitable method in jointly meeting the requirements under the Ordinance. Such coordination will be complete within 6 months of approval of the Plan.

Alternatively Inmar can operate a multi-lingual, (English, Spanish, Chinese and Tagalog), toll-free call

center that interested parties can call to learn more about the Stewardship Plan, and best practices for disposal of Unwanted Covered Drugs. The call center is operated with live operators and will be staffed with a third party service to assist with live translation in the required languages. All operators are trained to assist and answer questions related to any and all questions related to the Stewardship Plan operation including but not limited to Authorized Collector kiosk support and service requests. County Residents will also be able to request information about the nearest drop-off site or Mail-Back Distribution Site, or request that a prepaid mailer is sent to them. Upon plan approval Inmar will coordinate with existing Plan Operators on a unified, single toll-free number for residents.

We have provided a call center map below which demonstrates call flows through the call center.

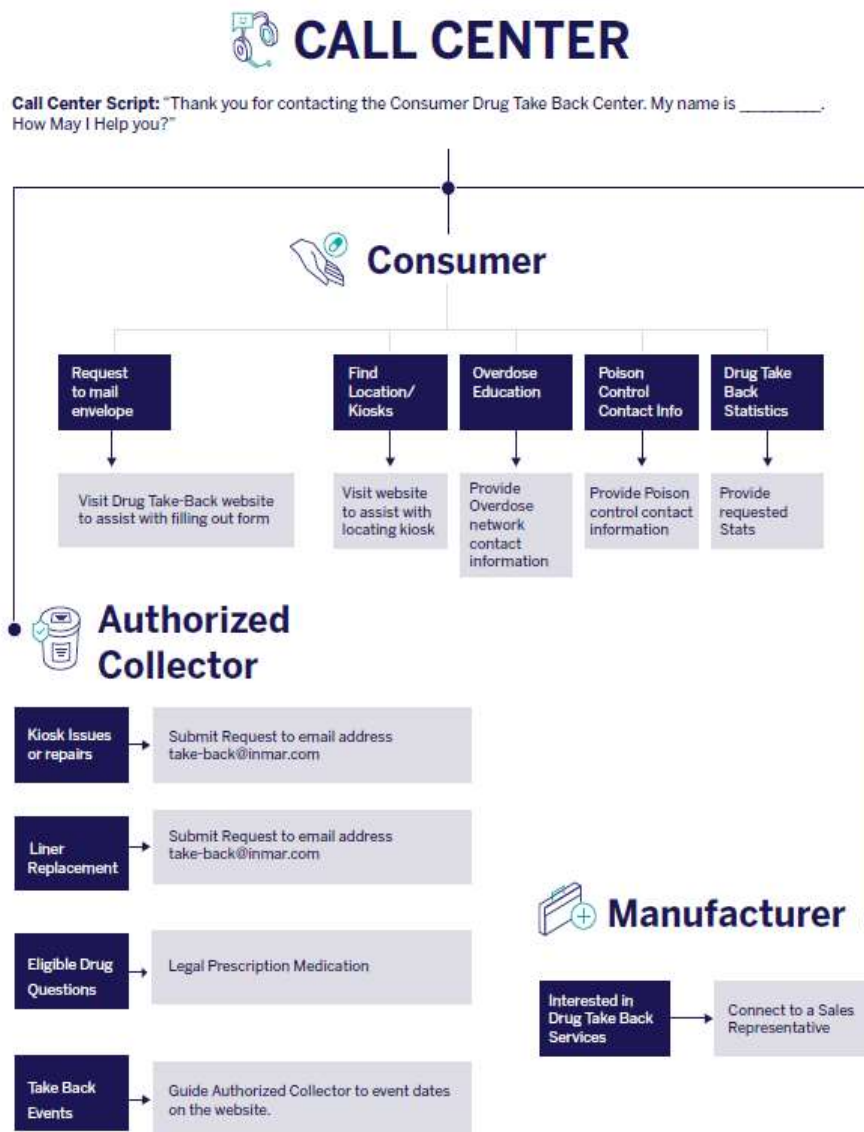

Figure 7: Call Center Flow

D. Educational Materials

Educational Brochure for Residents

Inmar provides an easily-consumable educational brochure for dissemination to interested parties including residents, pharmacists, retailers and health care practitioners upon request and at no charge. The educational brochure will be provided in Tagalog, Spanish, Chinese, and English.

The educational brochure will:

- Educate County residents about the appropriate use, storage, and disposal of Unwanted Medicine
- Provide County residents with clear steps to properly manage the disposal of their Unwanted Medicine including following instructions found on the medicine label, use of Kiosk Drop-Off Sites,
- Instructions on requesting a mail-back envelope
- Provide best-practices for in-home disposal where no disposal instructions are given on the drug labeling

All materials will be easily understandable by covered entities with varying levels of English proficiency and will leverage explanatory graphics to aid in comprehension.

Please see Appendix B for example materials.

Training Materials for Authorized Collectors

Inmar provides authorized collectors with easy to understand and standardized instructions explaining how to use the collection kiosk. Training material provided to authorized collectors include:

1. FAQs
2. Container Instructions
3. Steps to Start Document – Including Kiosk Maintenance requests
4. Installation Reference Guide
5. Serialization Tracker

Marketing tool kits are shipped with initial Kiosk and liner kits however additional materials can be requested via email at take-back@inmar.com. Authorized collector sites will also be routinely visited by Inmar staff to ensure they are adequately staffed and operating compliantly with the Plan.

Training material samples are provided in Appendix C. Note: Training materials will be updated upon Plan approval to include images reflecting appropriate PPE recommended for operating a Kiosk.

E. Public Outreach

Inmar's stewardship program will provide public outreach through the following channels:

Authorized Collector Marketing Support

To drive awareness and participation at a local level, Inmar will provide individual authorized collectors with a variety of marketing assets at no charge, including in-store signage, social media content kits, press release templates, a radio ad script, and scripts for pharmacy staff to let covered

entities know that they can safely dispose of their covered drugs at that location. Authorized collectors will be able to request additional marketing materials through the help desk.

Please see Appendix D for example materials.

Social Influencer Marketing

The 2016 acquisition of Collective Bias gave Inmar the ability to execute robust, data-driven social influencer marketing programs that activate shoppers and patients alike. On average, Inmar executes approximately 500 such programs annually.

Inmar has a curated network of more than 12,000 highly-vetted influencers who are experts at creating authentic, compelling content that can drive awareness and inspire participation among covered entities. Inmar utilizes sophisticated influencer selection, data-driven content distribution, and audience re-engagement tactics to ensure that content is hyper-relevant and that the covered entities receiving the content are the ones most inclined to take action.

Content can focus on an array of topical themes, however, based on the program requirements outlined in Chapter 7.90 San Mateo County Safe Drug Disposal Ordinance Section 7.90.100, Inmar's recommendation would be one, or a combination of, the following:

- Tips for safe storage of medications in the home prior to disposal
- Education about the implications of improper drug disposal
- Promotion of the drug take-back program, including directions on where and how to participate

Inmar executed a social influencer marketing program promoting drug take-back in April of 2019 which yielded exceptional results (see Sub-Section 7 for more information on impact measurement and reporting). The campaign generated 11.4MM impressions, but, more importantly, the posts themselves were highly engaging. The average click-through-rate (CTR) was 4.5% (a historical CTR benchmark in this category is 1.5 - 2.0%) and users spent an average of one minute and eight seconds on each post. Both metrics suggest users found the content compelling and useful. ROI for social influencer marketing campaigns is measured in terms of return on Total Media Value (the combined value of earned and paid media for the campaign). In this case, TMV return was favorable at 2.1x.

Please see Appendix D for sample social influencer content. We also invite you to view some of the top performing posts linked below:

- [*Life in Check Consumer Drug Take-Back receptacle | National Prescription Drug Take-Back Day by Meagan Harrell*](#)
- [*5 Easy Tips to Declutter Your Closet + Safe Medication Disposal by Valerie Clement*](#)
- [*How to Dispose of Unused Medications Safely - Mom Always Knows by Elizabeth Hurt*](#)

Targeted Media

Inmar's expert paid media team actively monitors social influencer content for the highest performers - looking beyond vanity metrics to focus on deeper measurements such as views and engagements. The most engaging content is promoted across social platforms as well as off-site media to amplify

the message around drug take-back to a targeted cohort of covered entities.

Lastly, in partnership with PlaceIQ, Inmar offers targeted ad units that allow messages to be delivered to covered entities that are physically near or in selected locations (e.g., near a kiosk) and provide after-action metrics, such as Place Visit Rate, which demonstrate in-store foot traffic among your target audience.

Impact Measurement

In accordance with Chapter 7.90 San Mateo County Safe Drug Disposal Ordinance Section 7.90.100, Inmar will provide a description of outreach initiatives in its annual report, but also aims to provide more frequent and actionable reporting on the impact of such initiatives.

With specific regard to social influencer marketing and targeted media, Inmar's measurement tools and philosophies have continuously set the industry standard with their emphasis on transparency and quantifiability over vanity metrics and theoretical explanations.

All paid and organic activity is measured using the industry's most powerful analytics suite to capture true ROI. Reporting will include:

- Third-party verified Content View & Engagement reporting
- Engagement breakdown by social platform, including Time on Content
- Social Content Ad™ (aka social media ad) performance data
- Total Media Value (TMV) calculations
- Thumbnail links to all influencer content, and performance metrics for individual influencer posts (including TMV for each post)

F. Biennial Survey

Ordinance 04736 Section 4.116.060(a)(4)

Inmar will coordinate with existing plan operators to conduct a biennial survey of San Mateo County Residents as well as pharmacists, veterinarians and health professionals who interact with patients on use of medicines after the first full year of operation of the Stewardship Plan. The aim of the survey questions will be to measure the percent awareness of the Stewardship Plan, assess to what extent drop-off sites and other collection methods are convenient and easy to use, and assess knowledge and attitudes about risks of abuse, poisonings, and overdoses from prescription and non-prescription drugs used in the home. Inmar will coordinate with existing plan operators to ensure that we do not overlap on communication channels and duplicate survey respondent results.

Draft survey questions will be submitted to the Director for review and comment at least 30 days prior to the initiation of the survey. Results of the survey will be reported to the Director and made available to the public on the website required in subsection (a)(3) within 90 calendar days of the end of the survey period. The privacy of all survey respondents will be maintained.

G. Language Translation

Ordinance 04736 Section 4.116.060(b)

All outreach methods will be translated into English, Spanish, Chinese and Tagalog.

H. Multiple Stewardship Plans

Ordinance 04736 Section 4.116.060(c)

Inmar will work with the Director to develop a single system of promotion for all stewardship plans when multiple plans exist. All collateral pieces will have consistent messaging to residents in coordination with other plans. Language in messaging to residents will be consistent no later than 6 months after approval is granted. Inmar will work with the existing Plan Operator to provide the Director with a mutually agreed upon document, outlining the principles of coordination, specifying the required elements of the single-system of promotion.

VII. Short-term and Long-term Goals

Ordinance 04736 Section 4.116.040(g)

	Short-Term (2022)	Long-Term (2023+)
Collection	<ul style="list-style-type: none"> ● Initiate program operation ● Place 51 drop-off sites (1 per 20,000 residents spread across the 5 per supervisorial districts) preferably at retail pharmacies, hospitals and clinics with on-site pharmacies, and law enforcement agencies <ul style="list-style-type: none"> ○ Inmar estimates collection of 20 lbs. per month per drop-off site on average for a total of 12,240 lbs. for 12 months with 51 kiosks placed ● Establish mail-back service in areas that are underserved by collection drop-off sites (3,000 lbs.) 	<ul style="list-style-type: none"> ● Increase drop-off site locations at a rate of one additional kiosk per supervisorial district ● Increase collection by 10% per year (equal to 13,464 with 56 kiosks placed)
Education & Promotion	<ul style="list-style-type: none"> ● Finalize a plan of coordination with med-project on a unified website, phone number and other promotional materials within 6 months of plan approval ● Establish a baseline of percentage of residents reached through social media and other targeted media outreach ● Provide training material to each authorized collector and establish a baseline for number of messages received by Inmar regarding training and knowledge gaps ● Educational brochures will be provided at collection sites at a minimum of 2 times per year in quantities of 50 in English and 25 in the other required languages or upon request of the collector. 	<ul style="list-style-type: none"> ● Reach 25% of population through plan media outreach efforts by the end of year 1. Reach 50% of population through plan outreach by the end of year 2. Reach and sustain a 75% saturation rate for plan outreach by the end of year 3 and beyond. ● All authorized collectors have been properly trained on collection and disposal as indicated by a reduction to baseline of messages received by Inmar from authorized collectors about training and knowledge gaps.

VIII. Additional Plan Considerations

Ordinance 04736 Section 4.116.040(h)

Existing Providers of Pharmaceutical Waste Services

To the extent that existing providers of pharmaceutical waste are already in operation, Inmar will determine if coordinating efforts creates efficiencies for the county and improves convenient and equitable access for county residents.

Furthermore, to the extent that there are other stewardship organizations, Inmar will seek to coordinate its activities with said programs within 6 months after Inmar’s stewardship program is approved. Inmar’s LifeInCheck™ Consumer Drug Take-Back website will ensure that all consumers can easily identify, understand, and access the collection services provided by Inmar and other stewardship organizations. Coordination efforts will include providing a single website and toll-free telephone number to access information about collection services for all approved programs.

Inmar will work with the current approved Plan Operator and submit to the Department a mutually agreed upon document outlining the principles of coordination. Such document will outline a single system of coordination to include the following elements: Kiosk Design, Kiosk Signage, Mailer instructional insert(s) or flyer(s), Mailer distribution site signage, Resident-facing Website, Resident Facing Toll-Free Phone Number, Promotion/Media to include standardized instructions to County residents and to the local health care community and pharmacies.

Package Separation & Recycling

DEA § 317.75(c) prohibits handling substances after they have been deposited into a collection kiosk. For this reason, Inmar is unable to separate and recycle drug packaging. However, Inmar can execute educational programs, as outlined in Section VI, to encourage county residents to separate unwanted covered drugs from their packaging and recycle the packaging prior to disposal.

Even though regulations prevent us from recycling drug packaging, Inmar still has a vested interest in reducing waste and improving our environment. Through our Rx Returns and related business lines, Inmar has saved over 20,000 barrels of oil, recovered over 11,000 megawatts of clean energy and powered over 900 homes in just the past two years alone. We will continue to look for opportunities to expand our eco-friendly efforts in San Mateo County.



Inmar Energy Metrics

Megawatts of Clean Energy Recovered:

2017 = 5,436
2018 = 5,643

Barrels of Oil Saved:

2017 = 9,896
2018 = 10,270

Homes Powered for a Year:

2017 = 482
2018 = 495

IX. Administrative and Operational Costs and Fees

Inmar’s plan includes multiple producers who equitably share the cost of implementation. Inmar represents producers in San Mateo County as well as the remainder of the United States where regulations require stewardship oversight. As such, each producer pays a fee for services performed by Inmar. This fee is based on several factors including market share of covered drugs throughout the county. Below is a list of costs that are covered by producers as part of their fee to Inmar:

- Collection and transportation supplies for each drop-off site;
- Acquisition of all secure collection bins for drop-off sites;
- Ongoing maintenance or replacement of secure collection bins, as requested by collectors;
- Prepaid, preaddressed mailers provided to disabled and/or home-bound County residents;
- Transportation of all collected covered drugs to final disposal, including costs of law enforcement escort if necessary;
- Environmentally sound disposal of all collected covered drugs under Section 4.116.070 of this chapter;
- Program promotion under Section 4.116.060 of this chapter; and
- Costs related to any review of a product stewardship plan for purposes of obtaining compliance with the California Environmental Quality Act (Cal. Pub. Res. Code § 21000, et seq.).

Retail Pharmacies are not expected to incur any costs for participation however any staff or staff duties performed by the retailer in conjunction with the plan are not costs covered by the Producers or Inmar.

X. Reporting

Ordinance 04736 Section 4.116.090

Within six months after the end of the first 12-month period of operation, and annually thereafter for a period covering January 1 – December 31, Inmar will submit a report describing the program’s activities during the previous reporting period. The report will include:

- (1) A list of participating producers
- (2) The amount by weight of covered drugs collected, including the amount by weight from each collection method used
- (3) A list of drop-off sites
- (4) The number of mailers provided for disabled and/or home-bound county residents
- (5) The locations where mailers were provided, as applicable
- (6) The dates and locations of collection events held, as applicable
- (7) The transporters used and the disposal facility or facilities used for all covered drugs
- (8) Whether any safety or security problems occurred during collection, transportation or disposal of unwanted covered drugs during the reporting period and, if so, what changes have or will be made to policies, procedures or tracking mechanisms to alleviate the problem and to improve safety and security in the future
- (9) A description of the public education, outreach and evaluation activities implemented during the reporting period
- (10) A description of how collected packaging was recycled to the extent feasible, including the recycling facility or facilities used
- (11) A summary of the stewardship program’s goals, the degree of success in meeting those goals in the past year, and, if any goals have not been met, what effort will be made to achieve the goals in the next year
- (12) The total expenditures of the stewardship program during the reporting period.

XI. APPENDIX

A. Drop-off and Mail-Back Sites	34
B. Kiosk Signage, Mail-back Inserts and Brochure	37
C. Training Material	43
D. Promotion Material	60
E. Applicable Permits and Licenses	65
F. Compliance Matrix	90

XII. Appendix A-1: List of Confirmed Drop-off Sites

Site Name	Site Address	Site City	Site Zip	District
SAFEWAY PHARMACY #1547	1450 HOWARD AVE	BURLINGAME	94010	1
SAFEWAY PHARMACY #2878	525 EL CAMINO REAL	MILLBRAE	94030	1
SAFEWAY PHARMACY #1138	1100 EL CAMINO REAL	BELMONT	94002	3
SAFEWAY PHARMACY #2719	525 EL CAMINO REAL	MENLO PARK	94025	3
SAFEWAY PHARMACY #0305	1071 EL CAMINO REAL	REDWOOD CITY	94063	4

XIII. Appendix A-2: List of Potential Drop-off Sites

Store Name	Store Address	Store City	Store Zip	District
A & O PENINSULA PHARMACY	1828 EL CAMINO REAL	BURLINGAME	94010	1
DBA: WALGREENS # 06655	1160 BROADWAY	BURLINGAME	94010	1
DBA: WALGREENS #12257	260 EL CAMINO REAL	BURLINGAME	94010	1
NOWRX	800 BURLWAY RD	BURLINGAME	94010	1
DBA WALGREENS #07970	45 S EL CAMINO REAL	MILLBRAE	94030	1
DBA: WALGREENS # 00625	615 BROADWAY	MILLBRAE	94030	1
ANCHOR DRUGS	161 SOUTH SPRUCE AVE	SOUTH SAN FRANCISCO	94080	1
CAREKINESIS	401 SOUTH CANAL STREET	SOUTH SAN FRANCISCO	94080	1
DBA: WALGREENS # 03346	399 EL CAMINO REAL	SOUTH SAN FRANCISCO	94080	1
DBA: WALGREENS #15397	2238 WESTBOROUGH BLVD	SOUTH SAN FRANCISCO	94080	1
DBA COSTCO PHARMACY #147	1001 METRO CENTER BLVD	FOSTER CITY	94404	2
DBA: WALGREENS # 00063	900 RALSTON AVENUE	BELMONT	94002	2
DBA: WALGREENS # 03296	191 EAST 3RD AVE.	SAN MATEO	94401	2
MARINER ADVANCED PHARMACY CORP	43 EAST 3RD AVE	SAN MATEO	94401	2
RITE AID #5902	666 CONCAR DRIVE	SAN MATEO	94402	2
DBA: WALGREENS # 05006	4070 S EL CAMINO REAL	SAN MATEO	94403	2
RITE AID #5903	1320 WEST HILLSDALE BLVD.	SAN MATEO	94403	2
TED'S VILLAGE PHARMACY INC	29 W 25TH AVE	SAN MATEO	94403	2

CVS PHARMACY # 16490	2220 BRIDGEPOINTE PKWY	SAN MATEO	94404	2
DBA: CVS/PHARMACY # 09330	325 SHARON PARK DR	MENLO PARK	94025	3
LPCH CHILDREN'S HOME PHARMACY	4600 BOHANNON DRIVE	MENLO PARK	94025	3
PHARMACA INTEGRATIVE PHARMACY, INC.	871 SANTA CRUZ AVENUE	MENLO PARK	94025	3
DBA: WALGREENS # 07087	643 SANTA CRUZ AVE	MENLO PARK	94025	3
DBA: WALGREENS #11261	520 PALMETTO AVE	PACIFICA	94044	3
DBA THE PILL CLUB	969 INDUSTRIAL ROAD	SAN CARLOS	94070	3
DBA: WALGREENS # 02126	1414 EL CAMINO REAL	SAN CARLOS	94070	3
STANFORD HEALTH CARE PAVILION C-1 PHARMA	450 BROADWAY	REDWOOD CITY	94063	4
DBA COSTCO PHARMACY #1042	2300 MIDDLEFIELD ROAD	REDWOOD CITY	94063	4
BERKSHIRE PHARMACY	11 BERKSHIRE AVE	REDWOOD CITY	94063	4
CVS PHARMACY # 16112	2485 EL CAMINO REAL	REDWOOD CITY	94063	4
NOB HILL PHARMACY #628	270 REDWOOD SHORES PARKWAY	REDWOOD CITY	94065	4
DBA: WALGREENS # 02939	333 EL CAMINO REAL	SAN BRUNO	94066	4
DBA CVS/PHARMACY #17710	1775 EAST BAYSHORE ROAD	EAST PALO ALTO	94303	4
COSTCO WHOLESALE NO 475	1600 EL CAMINO REAL BLVD	SOUTH SAN FRANCISCO	94080	5
CVS PHARMACY # 16111	5001 JUNIPERO SERRA BLVD	COLMA	94014	5
DBA: WALGREENS # 01807	22 SAN PEDRO RD	DALY CITY	94014	5
DBA: WALGREENS # 05365	6100 MISSION STREET	DALY CITY	94014	5
CVS PHARMACY # 16746	133 SERRAMONTE CTR	DALY CITY	94015	5
DBA: WALGREENS # 00324	216 WESTLAKE CENTER	DALY CITY	94015	5

XIV. Appendix A-3: List of Confirmed Mail-Back Sites

STORE NAME	STORE ADDRESS	STORE CITY	Store Zip	DISTRICT #
LUCKY #748	1322 EL CAMINO REAL	SAN BRUNO	94066	1
ANCHOR DRUGS	161 SOUTH SPRUCE AVENUE	SOUTH SAN FRANCISCO	94080	1

DR. LAWRENCE L. CHAO - SAN MATEO OFFICE	1750 EL CAMINO REAL, SUITE 301	BURLINGAME	94010	1
MINDFUL HEALTH SOLUTIONS - BURLINGAME	1860 EL CAMINO REAL, SUITE 250	BURLINGAME	94010	1
LUCKY #726	45 MURCHISON DR	MILLBRAE	94030	1
APRIA - SOUTH SAN FRANCISCO LOCATION	480 CARLTON COURT	SOUTH SAN FRANCISCO	94080	1
UCPC SAN MATEO PRIMARY CARE	1100 Park Place, Suite 100	SAN MATEO	94403	2
SAFEWAY 970	1655 EL CAMINO REAL	SAN MATEO	94402	2
ALEGRE HOME CARE - PENINSULA	1660 S. AMPHLETT BLVD., SUITE 128	SAN MATEO	94402	2
SAN MATEO MC O/P PHARMACY	222 39TH AVE	SAN MATEO	94403	2
LUCKY #710	919 EDGEWATER BLVD	FOSTER CITY	94404	2
LUCKY #749	1133 OLD COUNTY RD	SAN CARLOS	94070	3
CALIFORNIA SINUS CENTER	3351 EL CAMINO REAL SUITE 200	ATHERTON	94027	3
SLEEP QUEST - SAN CARLOS	981 INDUSTRIAL ROAD, SUITE B	SAN CARLOS	94070	3
RAVENSWOOD FAMILY DENISTRY	1807 BAY ROAD	EAST PALO ALTO	94303	4
RAVENSWOOD FAMILY HEALTH	1885 BAY ROAD	EAST PALO ALTO	94303	4
LUCKY #745	200 WOODSIDE PLAZA	REDWOOD CITY	94061	4
SAFEWAY 747	850 WOODSIDE RD	REDWOOD CITY	94061	4
BRIGHT LIFE	10 BELLCREST AVENUE	DALY CITY	94015	5
ACCLAIM HOME CARE INC. - DALEY CITY OFFICE	318 WEST LAKE CENTER, UNIT 227	DALEY CITY	94015	5
ANX HOSPICE CARE	455 HICKEY BLVD, SUITE 320	DALY CITY	94015	5
ANX HOME HEALTHCARE	455 HICKEY BLVD, SUITE 415	DALY CITY	94015	5
LUCKY #707	6843 MISSION ST	DALY CITY	94015	5

XV. Appendix B: Promotional Signage, Mail-back Inserts and Brochure

All Promotional material will be coordinated with other plan operators and submitted to the SMC for final approval.

Kiosk prototype and signage



ACCEPTED

MEDICATIONS IN ANY DOSAGE FORM, EXCEPT FOR THOSE LISTED BELOW, IN THEIR ORIGINAL CONTAINER OR SEALED BAG.



NOT ACCEPTED

HERBAL REMEDIES, VITAMINS, SUPPLEMENTS, COSMETICS, OTHER PERSONAL CARE PRODUCTS, MEDICAL DEVICES, BATTERIES, MERCURY-CONTAINING THERMOMETERS, SHARPS, AND ILLICIT-DRUGS.

Name: 123 Pharmacy
Contact: (555) 555-5555



MEDICINE DISPOSAL

Eliminación de medicamentos
药物处置
Pagtatapon ng gamot

SAFELY DISPOSE OF UNWANTED & EXPIRED MEDICINES



01

Cross out or remove personal identifying information from the medicine bottle.



02

Leave the product in its original container or place solid medicines in a sealed plastic bag.*

*If transferring medications to a sealed bag, please be sure to recycle all remaining packaging.



03

Put medicine in the kiosk.

ONLY SCHEDULE II-V CONTROLLED AND NON-CONTROLLED SUBSTANCES THAT ARE LAWFULLY POSSESSED BY THE ULTIMATE USER ARE ACCEPTABLE TO BE PLACED IN THE KIOSK. SCHEDULE I CONTROLLED SUBSTANCES, ILLICIT OR DANGEROUS SUBSTANCES, AND ANY CONTROLLED SUBSTANCES NOT LAWFULLY POSSESSED BY THE ULTIMATE USER MAY NOT BE PLACED IN THE KIOSK.

For more information about the drug disposal program,
please go to safemedicinedrop.com or call 1-888-371-0717.

Promotional Brochure for Residents

PROTECT YOUR FAMILIES,
COMMUNITIES, AND THE ENVIRONMENT

SAFELY DISPOSE OF UNUSED MEDICINES

WHAT SHOULD YOU DO WITH YOUR EXPIRED
OR UNWANTED MEDICINES IN OREGON

There are a number of ways to dispose of expired or unwanted medications.

Go to www.safemedicatedrop.com to learn more.



CONVENIENT
KIOSK
LOCATIONS



MAIL-BACK



TAKE-BACK
EVENTS

For more information about the program,
go to www.safemedicatedrop.com
or call 1-800-361-9948



WHY IS SAFE DRUG DISPOSAL IMPORTANT FOR PUBLIC HEALTH?

- Unused or expired prescription medications can lead to accidental poisoning, overdose, and abuse.
- Unused prescription drugs thrown in the trash can be retrieved and abused or illegally sold.
- Unused drugs that are flushed contaminate the water supply.

This material has been provided for the purpose of compliance with legislation and does not necessarily reflect the views of Inmar Intelligence or the Producers participating in the Inmar Intelligence (Source: U.S. Food and Drug Administration)

PROTECT YOUR FAMILIES,
COMMUNITIES, AND THE ENVIRONMENT

SAFELY DISPOSE OF UNUSED MEDICINES

BEFORE DISPOSAL CHECK THE PACKAGE

If there are specific instructions for disposal on the label, package or package insert, please follow those instructions.

DISPOSAL OPTIONS



CONVENIENT KIOSK DROP OFF LOCATIONS

To find drug disposal kiosk drop-off sites in your area, visit www.safemedicatedrop.com.



MAIL-BACK ENVELOPES

Mail-Back Services for Unwanted Medicines. Visit the Mail-Back section of www.safemedicatedrop.com to order a Mail-Back Package.



TAKE-BACK EVENTS

Local Take-Back events offer residents a free and convenient way to dispose of expired or Unwanted Medicines. Visit the Take-Back Events section of the DEA site at takebackday.dea.gov for information on events in your area.

For more information about the program, go to www.safemedicatedrop.com or call 1-800-361-9948

WHAT CAN YOU DISPOSE OF IN A KIOSK OR MAILBACK ENVELOPE?



ACCEPTED:

Medications in any dosage form, except for those listed below, in their original container or sealed.*

*If transferring medications to a sealed bag, please be sure to recycle all remaining packaging



NOT ACCEPTED:

Herbal remedies, pet medications, vitamins, supplements, cosmetics, other personal care products, medical devices, batteries, mercury-containing thermometers, sharp, and illicit drugs.



This material has been provided for the purpose of compliance with legislation and does not necessarily reflect the views of Inmar Intelligence or the Producers participating in the Inmar Intelligence (Source: U.S. Food and Drug Administration) Product Stewardship Plan

11302 CDTB OR 07/16/2021

Mail-back Inserts

MAIL-BACK PACKAGE IS FOR

UNWANTED OR EXPIRED MEDICATIONS



ACCEPTED

Medications in any dosage form, except those listed below, in their original container or sealed bag.*

*If transferring medications to a sealed bag, please be sure to recycle all remaining packaging.

NOT ACCEPTED

Herbal remedies, vitamins, supplements, cosmetics, other personal care products, inhalers, medical devices, batteries, mercury-containing thermometers, sharps, and illicit drugs.

To protect your privacy, consumers are reminded to remove all personally identifiable information on prescription labels or materials before using any of the disposal options listed above.

This material has been provided for the purpose of compliance with legislation and does not necessarily reflect the views of Inmar Intelligence or the Producers participating in the Inmar Intelligence Product Stewardship Plan.

MAIL-BACK PACKAGE IS FOR **INHALERS**



ACCEPTED

Inhalers

NOT ACCEPTED

Unwanted medicines that are not inhalers, herbal remedies, vitamins, supplements, cosmetics, other personal care products, medical devices, batteries, mercury-containing thermometers, sharps, and illicit drugs.

Note: Only place undamaged inhalers in their original containers in the Inhaler Mail-Back Package. Inhaler Mail-Back Packages can only be used for inhalers and cannot accept other types of items.

To protect your privacy, consumers are reminded to remove all personally identifiable information on prescription labels or materials before using any of the disposal options listed above.

This material has been provided for the purpose of compliance with legislation and does not necessarily reflect the views of Inmar Intelligence or the Producers participating in the Inmar Intelligence Product Stewardship Plan.

**MAIL-BACK PACKAGE IS FOR
PRE-LOADED PRODUCTS
CONTAINING A SHARP
AND AUTO-INJECTORS**



ACCEPTED

Pre-loaded products containing a sharp and auto-injectors.

NOT ACCEPTED

Unwanted medicines that are not pre-loaded products containing a sharp or auto-injectors, inhalers, herbal remedies, vitamins, supplements, cosmetics, other personal care products, medical devices, batteries, mercury-containing thermometers, sharps, and illicit drugs.

Note: Injector Mail-Back Packages can only be used for pre-filled injector products and cannot accept other types of items.

This material has been provided for the purpose of compliance with legislation and does not necessarily reflect the views of Inmar Intelligence or the Producers participating in the Inmar Intelligence Product Stewardship Plan.

XVI. Appendix C: Training Material

Training material provided to authorized collectors include:

1. FAQs
2. Container Instructions
3. Steps to Start Document
4. Installation Reference Guide
5. Serialization Tracker

All of the aforementioned documents are provided on the following pages.

Note: Training materials will be updated upon Plan approval to include images reflecting appropriate PPE recommended for operating a Kiosk.

GETTING STARTED

KIOSK

You will receive your Consumer Drug Take-Back kiosk and your supplies in separate shipments. After unpacking the Consumer Drug Take-Back kiosk, it must be installed according to the “Responsible Disposal Act” Rule which means it must be connected to a wall or the floor ensuring the kiosk is secure. Your kiosk will come pre-drilled in the bottom to make installation easier. Please see the installation instructions included in this email.

Your usage of the Inmar Consumer Drug Take-Back Program indicates your agreement to accept responsibility for following the Federal and State Guidelines. DEA’s Final Rule, which implements the Secure and Responsible Drug Disposal Act of 2010 (“the Disposal Act”).

SUPPLIES

After completing the proper installation of your Consumer Drug Take-Back kiosk, you should unpack your supplies.

Included are supplies to operate your Consumer Drug Take-Back program for 3 shipments. Upon Inmar’s receipt of your second container (return) shipment, we will automatically send your next 3 shipment supply package so you will always have the necessary supplies on hand. Staged shipping of your supplies alleviates your need to store large supply quantities.

Each shipment contains 3 individually-packaged kits with unique components to each kit. DO NOT rearrange contents between kits.

Each kit contains one of each of the following:

- Serialized Inner Liner
- Absorption pad
- Serialization Tracking Sheet (emailed separately)
- Black Zip Tie
- Set of instructions (Single Page)
- Numbered and pre-labeled cardboard box

It is important for you to document receipt of the serialized Inner Liners on your tracking form. To assist, Inmar has provided the Serialization Tracking sheet (Inner Liner Tracking Form). Maintain a copy of the completed Serialization Tracking Sheet in your files for at least 3 years (at the collector’s registered location). Refer to 16 CCR §1776.6.

CONSTRUCTING YOUR INNER CONTAINER

Construct 1 cardboard container applying an appropriate amount of tape to the bottom to ensure safe transportation. Seal the middle seam and both outside seams. Leave no untaped spaces along the seams and no less than 3 inches of tape overhang on each side. We recommend 2 strips of tape across the bottom seam and 2 strips of tape over the edge seams and 2 strips of tape across the bottom of the container placed diagonally. See illustration to right.

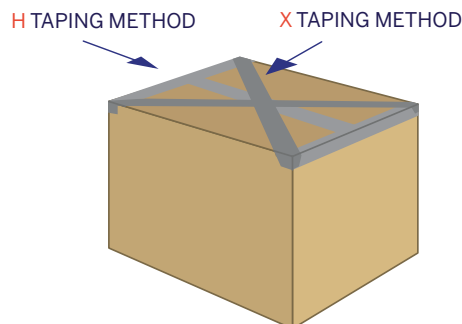

NOTE: All direct contact with the unsealed Consumer Drug Take-Back liner must be performed by two pharmacy personnel.

PREPARING YOUR CONTAINER FOR USAGE

1. Place Serialized Inner Liner into the box and fold excess material at top over box flaps. Leave Black Zip Tie taped to the Liner for later use. (When inserting Inner Liner, check to ensure Serial Number on Serialized Inner Liner matches Serial Number on the shipping container.)
2. Place absorbent pad into the installed Liner.
3. Install the lined box (now the "Container") into the Collection Kiosk.
4. Immediately document installation of Container (column 3 of the Serialization Tracking Sheet).
5. Store remaining spare kits securely for future use.
6. Lock bottom door and unlock top door to begin CDTB collection.

NOTE: All direct contact with the unsealed Consumer Drug Take-Back liner must be performed by two pharmacy personnel.

PREPARING YOUR CONTAINER FOR SHIPPING

Note: The total weight of the Container ready for shipping MAY NOT EXCEED 66 POUNDS IN WEIGHT.

1. Unlock and open bottom door.
2. Remove full Container from Collection Kiosk.
DO NOT sort, count or inventory pharmaceuticals or touch contents of Liner prior to sealing.
3. Immediately seal the Serialized Inner Liner by gathering the top of the Liner, bending the gathered portion at the halfway point and folding the top half alongside the bottom half. For extra security, bend the gathered portion at the halfway point a 2nd time. While folding Liner, keep Serial Number on Liner visible. Securely cinch the provided Black Zip Tie around both halves of the gathered portion of the Liner to secure the top. Ensure that the zip tie is completely above the exposed end of the top half of the gathered portion and that the zip tie is fully tightened. This will provide an airtight seal at the open end of the Liner to prevent leakage of any trace liquids that may be inside. See next page for illustration.
4. Close and tape the box top. Seal the middle seam and both outside seams. Leave no untaped spaces along the seams and no less than 3 inches of tape overhang on each side. We recommend 2 strips of tape across the top seam and 2 strips of tape over the edge seams and 2 strips of tape across the top of the container placed diagonally. See illustration of taping method above.
5. Document removal of Container (in column 4 of Serialization Tracking Sheet).
6. Store the sealed Container in a secure location until shipped.

SHIPPING AND RECORD KEEPING

Note: Container is pre-labeled and ready to return. The marking requirements of 49 CFR 172.301(c) do not apply. The container shall not contain any markings to indicate that the contents contain controlled substances.

1. Ship in accordance with the DOT Special Permit.
Container comes pre-paid and pre-labeled for shipping.
2. When the Liner is shipped, complete column 5 on the Serialization Tracking Sheet. The completed Serialization Tracking Sheet is a record of Liner Events and should be filed in accordance with DEA guidelines. Schedule a pickup on FedEx.com by clicking "Shipping" then from the drop-down menu selecting "Schedule & Manage Pickups."
3. Maintain a copy of the completed Serialization Tracking Sheet in your files for at least 3 years (at the collector's registered location). Refer to 16 CCR §1776.6.
4. Inmar will maintain your modified Form 41 noting destruction date and time on file and will provide it to you upon request.

Click "Schedule a pickup." When prompted to log in, go to the "New FedEx.com Users" column and click "FedEx Ground Return Pickup." Enter the tracking ID from the shipping label and enter other information needed. On special instructions, describe exactly where in the store the pharmacy/box is being kept.

QUICK STEPS

TO START

- 01** Install the Consumer Drug Take-Back Kiosk per DEA guidelines.
- 02** Properly tape container at bottom.
- 03** Place Serialized Inner Liner inside with top folded over container flaps.
(When inserting Serialized Inner Liner, check to ensure Serial Number on Inner Liner matches Serial Number on the shipping container.)
- 04** Place absorbent pad in bottom of Serialized Inner Liner.
- 05** Document the installation of the container on the Serialization Tracking Sheet.
- 06** Install container inside Consumer Drug Take-Back kiosk.
- 07** Lock bottom door and unlock top door to begin drug take-back collection.

TO CLOSE

- 01** Open bottom door.
- 02** Remove full container, total weight of container **may not exceed 66lbs in weight.**
- 03** Ensure the Serial Number is visible before using a zip tie to secure Serialized Inner Liner bag top.
- 04** Document the removal of the container on the Serialization Tracking Sheet.
- 05** Properly tape container at top.
- 06** Container is pre-labeled for return shipment.
- 07** Schedule pickup with FedEx.

NOTE: All direct contact with the unsealed Consumer Drug Take-Back liner must be performed by two pharmacy personnel.

HOW TO SEAL THE LINER TO PREPARE FOR SHIPPING



- 01**
Immediately seal the Serialized Opaque Liner by gathering the top of the Liner.

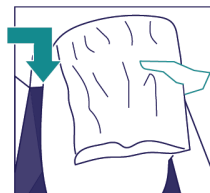

- 02**
Bend the gathered portion at the halfway point and fold the top half alongside the bottom half.



- 03**
Repeat Step 2 - Again bend the gathered portion at the halfway point and folding the top half alongside the bottom half.

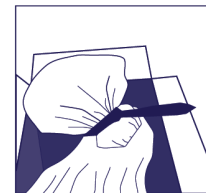

- 04**
Cinch and fully tighten the provided Black Zip Tie around both halves of the gathered portion of the Liner to secure the top.

1. MAINTENANCE AND CLEANLINESS OF KIOSK

The kiosk should be kept free of dirt and debris both inside and out. After an inner liner is removed for shipping, the pharmacist or servicing technician should look around the inside of the kiosk as well as the outside. The interior and exterior of the kiosk should be kept clean and free of

debris so as to not disrupt the intended functioning of the kiosk. Make sure the drop-door is in proper working order at all times when unlocked. In the event of any malfunction or maintenance needs, refer to procedures for requesting maintenance below.

2. PROCEDURES FOR REQUESTING MAINTENANCE

Should any portion of the kiosk become inoperable (key is lost, lock malfunctions, door hinge becomes unusable, etc.), Inmar's helpdesk can be reached by emailing take-back@inmar.com and describing the issue at hand. This inbox is

monitored by a team of people who are fully dedicated to the consumer drug take-back team at Inmar. The team will triage the request, contact the pharmacist or pharmacy manager if needed and solve the issue at hand.

3. PROCEDURES FOR ENSURING THAT THE CONTAINER IS REMOVED IN A TIMELY MANNER AND WHAT TO DO IF IT'S NOT.

The pharmacist should remove the container when it is full and prepare for shipping as described on this training document. After filling out the necessary information on the FedEx ship manager site, or providing the information via telephone, the liner should be securely locked in a location in

the pharmacy until it is picked up by FedEx personnel. If for any reason the pickup does not happen within 48 hours after being scheduled, please reach out to take-back@inmar.com and a consumer drug take-back team member will assist with this process.





LIFE **IN** CHECK™
CONSUMER DRUG TAKE-BACK

COLLECTION CONTAINER VISUAL INSTRUCTIONS

CONSTRUCTION, INSTALLATION, REMOVAL
AND SHIPPING OF COLLECTION CONTAINER

CALIFORNIA GUIDELINES

Questions: Contact Consumer Drug Take-Back Client Service Team
take-back@inmar.com

1-800-350-0396 Option 6, Mon-Fri 8am-5pm EST

KIT CONTENTS

Each shipment contains 3 individually packaged kits with unique components to each kit.

DO NOT rearrange contents between kits.

THE KIT:

- 1 The kit will arrive in a package similar to this.
- 2 The kit will include three numbered and pre-labeled boxes.



Each kit contains one of each of the following items:

- 1 Zip tie
- 2 Absorption pad
- 3 Inner liner
- 4 Numbered and pre-labeled box



IMPORTANT:

For every shipment – serial number on inner liner & serial number on cardboard container **MUST MATCH**.

NOTE: All direct contact with the LifeInCheck Consumer Drug Take-Back Container should be performed by two pharmacy personnel.

KIT INSTRUCTIONS— INSTALLING A NEW COLLECTION CONTAINER

1 Document the serial number and receipt of each inner liner on the Drug Disposal Serialization Tracking Sheet.

DRUG DISPOSAL SERIALIZATION TRACKING SHEET INNER LINER TRACKING FORM					
Name of Collecting Pharmacy		Address of Collecting Pharmacy		Collecting Pharmacy DEA #	
Size of Liner		Address of Reverse Distributor/Disposal Site		Reverse Distributor/Disposal Site DEA #	
SERIAL NUMBER	Date Liner Acquired (Purchase & Signature)	Date Liner Installed (Purchase & Signature)	Date Removed (Purchase & Signature)	Date Transferred to Storage (Purchase & Signature)	Date Shipped (Purchase & Signature)
Ex: 32567	4/26/19 John Jones Sally Smith	4/26/19 John Jones Sally Smith Sally Smith	5/26/19 John Jones Sally Smith Sally Smith	5/26/19 John Jones Sally Smith Sally Smith	5/23/19 John Jones Sally Smith Sally Smith

2 Close and tape the box bottom. Seal the middle seam and both outside seams. Leave no un-taped spaces along the seams. We recommend 1 strip of tape across the bottom seam, 2 strips of tape over the edge seams and 2 strips of tape across the bottom of the box placed diagonally. See illustration to right.

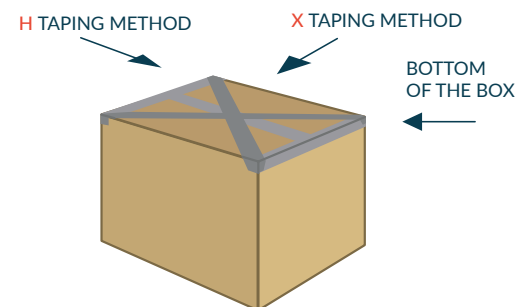

3 Place inner liner into the box and fold excess material at top over box flaps.



KIT INSTRUCTIONS— INSTALLING A NEW COLLECTION CONTAINER

4 Tape the zip tie to the inside of the door for later use.



5 Place absorbent pad into the installed inner liner.



6 Install the lined box (now the “Container”) into the collection kiosk.



KIT INSTRUCTIONS— INSTALLING A NEW COLLECTION CONTAINER

7 Immediately document installation of Container on the Drug Disposal Serialization Tracking Sheet.

DRUG DISPOSAL SERIALIZATION TRACKING SHEET INNER LINER TRACKING FORM					
Name of Collecting Pharmacy		Address of Collecting Pharmacy		Collecting Pharmacy DEA #:	
Size of Liner		Address of Reverse Distributor/Disposal Site		Reverse Distributor/Disposal Site DEA #:	
SERIAL NUMBER	Date Liner Acquired (Pharmacy)	Date Liner Installed (Pharmacy & Signatures)	Date Removed (Pharmacy & Signatures)	Date Transferred to Storage (Pharmacy & Signatures)	Date Shipped (Pharmacy & Signatures)
Ex: 32587	4/26/19 <i>John, Yvonne</i>	4/26/19 John Jones <i>John, Yvonne</i> Sally Smith <i>Sally Smith</i>	5/26/19 John Jones <i>John, Yvonne</i> Sally Smith <i>Sally Smith</i>	5/26/19 John Jones <i>John, Yvonne</i> Sally Smith <i>Sally Smith</i>	5/27/19 John Jones <i>John, Yvonne</i> Sally Smith <i>Sally Smith</i>

8 Lock the bottom door and unlock the drop door at the top of the kiosk to begin drug disposal collection.



9 Store remaining spare kits securely for future use.



10 Use the Drug Disposal Serialization Tracking Sheet to document all “inner liner events.”

DRUG DISPOSAL SERIALIZATION TRACKING SHEET INNER LINER TRACKING FORM					
Name of Collecting Pharmacy		Address of Collecting Pharmacy		Collecting Pharmacy DEA #:	
Size of Liner		Address of Reverse Distributor/Disposal Site		Reverse Distributor/Disposal Site DEA #:	
SERIAL NUMBER	Date Liner Acquired (Pharmacy)	Date Liner Installed (Pharmacy & Signatures)	Date Removed (Pharmacy & Signatures)	Date Transferred to Storage (Pharmacy & Signatures)	Date Shipped (Pharmacy & Signatures)
Ex: 32587	4/26/19 <i>John, Yvonne</i>	4/26/19 John Jones <i>John, Yvonne</i> Sally Smith <i>Sally Smith</i>	5/26/19 John Jones <i>John, Yvonne</i> Sally Smith <i>Sally Smith</i>	5/26/19 John Jones <i>John, Yvonne</i> Sally Smith <i>Sally Smith</i>	5/27/19 John Jones <i>John, Yvonne</i> Sally Smith <i>Sally Smith</i>

NOTE: All direct contact with the LifeInCheck Consumer Drug Take-Back Container should be performed by two pharmacy personnel.

KIT INSTRUCTIONS— REMOVING AND SEALING A FULL COLLECTION CONTAINER

Note: The total weight of the Container ready for shipping may not exceed 66 pounds.

- 1 Unlock and open bottom door.



- 2 Remove full Container from collection kiosk. **DO NOT** sort, count or inventory pharmaceuticals or touch contents of inner liner prior to sealing.



KIT INSTRUCTIONS— REMOVING AND SEALING A FULL COLLECTION CONTAINER

- 3** Immediately seal the inner liner by gathering the top of the liner.
- 4** Bend the gathered portion at the halfway point and fold the top half alongside the bottom half.
- 5** Repeat Step 4 - Again bend the gathered portion at the halfway point and fold the top half alongside the bottom half.



KIT INSTRUCTIONS— REMOVING AND SEALING A FULL COLLECTION CONTAINER

- 6** Cinch and fully tighten the provided zip tie around both halves of the gathered portion of the liner to secure the top.



- 7** Close and tape the box top. Seal the middle seam and both outside seams. Leave no un-taped spaces along the seams. We recommend 1 strip of tape across the top seam, 2 strips of tape over the edge seams and 2 strips of tape across the top of the Container placed diagonally. See illustration to right.

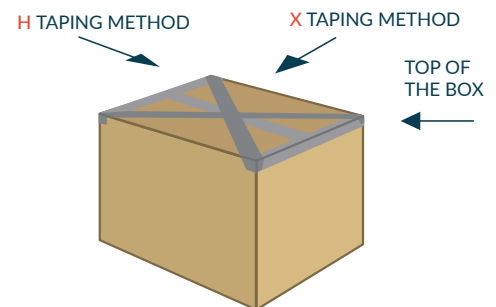

KIT INSTRUCTIONS— REMOVING AND SEALING A FULL COLLECTION CONTAINER

8 Document removal of Container on the Drug Disposal Serialization Tracking Sheet.

DRUG DISPOSAL SERIALIZATION TRACKING SHEET INNER LINER TRACKING FORM					
Name of Collecting Pharmacy		Address of Collecting Pharmacy		Collecting Pharmacy DEA #	
Size of Liner		Address of Reverse Distributor/Disposal Site		Reverse Distributor/Disposal Site DEA #	
SERIAL NUMBER	Date Liner Acquired (Signature)	Date Liner Installed (Name & Signature)	Date Removed (Name & Signature)	Date Transferred to Storage (Name & Signature)	Date Shipped (Name & Signature)
Ex: 32587	4/26/19 <i>John Jones</i>	4/26/19 <i>John Jones</i> <i>Sally Smith</i>	5/26/19 <i>John Jones</i> <i>Sally Smith</i>	5/26/19 <i>John Jones</i> <i>Sally Smith</i>	5/27/19 <i>John Jones</i> <i>Sally Smith</i>

9 Store the sealed Container in a secure location until shipped. The Container is pre-labeled for shipping. Document the shipping of the Container on the Drug Disposal Serialization Tracking Sheet.

DRUG DISPOSAL SERIALIZATION TRACKING SHEET INNER LINER TRACKING FORM					
Name of Collecting Pharmacy		Address of Collecting Pharmacy		Collecting Pharmacy DEA #	
Size of Liner		Address of Reverse Distributor/Disposal Site		Reverse Distributor/Disposal Site DEA #	
SERIAL NUMBER	Date Liner Acquired (Signature)	Date Liner Installed (Name & Signature)	Date Removed (Name & Signature)	Date Transferred to Storage (Name & Signature)	Date Shipped (Name & Signature)
Ex: 32587	4/26/19 <i>John Jones</i>	4/26/19 <i>John Jones</i> <i>Sally Smith</i>	5/26/19 <i>John Jones</i> <i>Sally Smith</i>	5/26/19 <i>John Jones</i> <i>Sally Smith</i>	5/27/19 <i>John Jones</i> <i>Sally Smith</i>

PLEASE NOTE:

Your cardboard container is pre-labeled for shipping. This label is pre-paid with FedEx and must not be copied.

Additional charges may apply for non-compliance.

Questions: Contact Consumer Drug Take-Back Client Service Team
take-back@inmar.com

1-800-350-0396 Option 6, Mon-Fri 8am-5pm EST

INSTALLATION INSTRUCTIONS

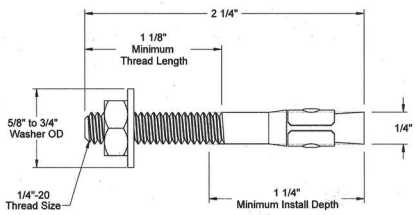
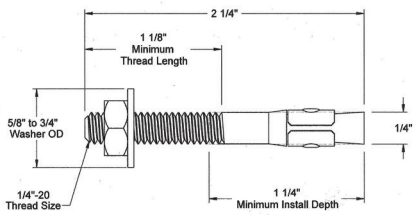
 <p>ANCHOR FOR CONCRETE FLOOR</p>	 <p>SCREW FOR WOOD FLOOR</p>	<p>McMaster-Carr - Flanged Hex Head Screws for Wood, Hot-Dipped Galvanized Steel, 1/4\" data-bbox="345 205 495 215"> Page 1 of 2</p> <p>McMASTER-CARR.</p> <p>Flanged Hex Head Screws for Wood Hot-Dipped Galvanized Steel, 1/4\" data-bbox="345 235 495 255"> Size, 2\" data-bbox="345 255 495 265"> Length</p> <p>In stock \$10.09 per pack of 50 95524150</p> <table border="1" style="width: 100%; border-collapse: collapse;"> <tr> <td>Material</td> <td>Hot-Dipped Galvanized Steel</td> </tr> <tr> <td>Screw Size</td> <td>1/4"</td> </tr> <tr> <td>Screw Size Decimal Equivalent</td> <td>0.2500"</td> </tr> <tr> <td>Length</td> <td>2"</td> </tr> <tr> <td>Head</td> <td>Hex</td> </tr> <tr> <td>Width</td> <td>0.375"</td> </tr> <tr> <td>Height</td> <td>0.28"</td> </tr> <tr> <td>Flange Diameter</td> <td>0.56"</td> </tr> <tr> <td>Flange Style</td> <td>External Hex</td> </tr> <tr> <td>Drive Style</td> <td>Phillips</td> </tr> <tr> <td>Approximate Threads per Inch</td> <td>18</td> </tr> <tr> <td>Thread Direction</td> <td>Right Hand</td> </tr> <tr> <td>Threading</td> <td>Partially Threaded</td> </tr> <tr> <td>Minimum Thread Length</td> <td>1"</td> </tr> <tr> <td>Tapping Method</td> <td>Thread Forming</td> </tr> <tr> <td>Head Type</td> <td>Hex</td> </tr> <tr> <td>Hex Head Profile</td> <td>Standard</td> </tr> <tr> <td>Tip Type</td> <td>Pointed</td> </tr> <tr> <td>Shank Cross Section</td> <td>Round</td> </tr> <tr> <td>System of Measurement</td> <td>Inch</td> </tr> <tr> <td>Screw Features</td> <td>Flanged</td> </tr> <tr> <td>For Use In</td> <td>Wood</td> </tr> <tr> <td>Specifications Met</td> <td>ASTM A193</td> </tr> <tr> <td>RoHS</td> <td>Compliant</td> </tr> </table> <p>These steel screws are hot-dipped galvanized to resist corrosion in wet environments and are a good choice for ACO-treated (arsenic-free) lumber. The flange reduces the risk of cracking material and the hex head provides a secure grip with a wrench. They press threads into material for a tight, secure hold. To prevent splitting, drill a pilot hole slightly smaller than the screw. Head height includes the flange. Length is measured from under the head.</p> <p>McMASTER-CARR Cab. PART NUMBER 91578A104 910/www.mcmaster.com Stud Anchor for Concrete © 2016 McMaster-Carr Supply Company</p>	Material	Hot-Dipped Galvanized Steel	Screw Size	1/4"	Screw Size Decimal Equivalent	0.2500"	Length	2"	Head	Hex	Width	0.375"	Height	0.28"	Flange Diameter	0.56"	Flange Style	External Hex	Drive Style	Phillips	Approximate Threads per Inch	18	Thread Direction	Right Hand	Threading	Partially Threaded	Minimum Thread Length	1"	Tapping Method	Thread Forming	Head Type	Hex	Hex Head Profile	Standard	Tip Type	Pointed	Shank Cross Section	Round	System of Measurement	Inch	Screw Features	Flanged	For Use In	Wood	Specifications Met	ASTM A193	RoHS	Compliant
Material	Hot-Dipped Galvanized Steel																																																	
Screw Size	1/4"																																																	
Screw Size Decimal Equivalent	0.2500"																																																	
Length	2"																																																	
Head	Hex																																																	
Width	0.375"																																																	
Height	0.28"																																																	
Flange Diameter	0.56"																																																	
Flange Style	External Hex																																																	
Drive Style	Phillips																																																	
Approximate Threads per Inch	18																																																	
Thread Direction	Right Hand																																																	
Threading	Partially Threaded																																																	
Minimum Thread Length	1"																																																	
Tapping Method	Thread Forming																																																	
Head Type	Hex																																																	
Hex Head Profile	Standard																																																	
Tip Type	Pointed																																																	
Shank Cross Section	Round																																																	
System of Measurement	Inch																																																	
Screw Features	Flanged																																																	
For Use In	Wood																																																	
Specifications Met	ASTM A193																																																	
RoHS	Compliant																																																	
		<table border="1" style="width: 100%; border-collapse: collapse;"> <tr> <th>DATE</th> <th>SYM</th> <th>REVISIONS RECORD</th> <th>AUTH</th> <th>DR</th> <th>CK</th> </tr> <tr> <td>07/18/2017</td> <td>A</td> <td>RELEASED FOR PRODUCTION</td> <td>WM</td> <td>KQ</td> <td></td> </tr> </table>	DATE	SYM	REVISIONS RECORD	AUTH	DR	CK	07/18/2017	A	RELEASED FOR PRODUCTION	WM	KQ																																					
DATE	SYM	REVISIONS RECORD	AUTH	DR	CK																																													
07/18/2017	A	RELEASED FOR PRODUCTION	WM	KQ																																														

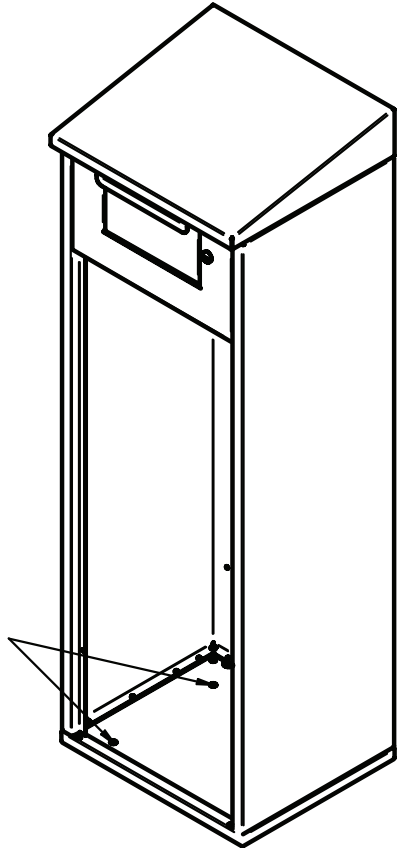

FIGURE 1

INSTALLATION

STEP 1: PLACE CABINET IN PERMANENT LOCATION

STEP 2: USING THE CABINET BASE AS A TEMPLATE, MARK FLOOR USING CLEARANCE HOLES AS SHOWN IN FIGURE 1

STEP 3: DRILL HOLES FOR FLOOR SUBSTRATE

Use four clearance holes in bottom for securing cabinet to floor.

DRUG DISPOSAL SERIALIZATION TRACKING SHEET INNER LINER TRACKING FORM



Serialization Tracking Sheet should be validated by 2 pharmacy employees.

Name of Collecting Pharmacy		Address of Collecting Pharmacy				Collecting Pharmacy DEA #:			
Size of Liner		Address of Reverse Distributor/Disposal Site				Reverse Distributor/Disposal Site DEA #			

1 SERIAL NUMBER	2 Date Liner Acquired (1 Signature)	3 Date Liner Installed (2 Names & Signatures)		4 Date Removed (2 Names & Signatures)		5 Date Transferred to Storage (2 Names & Signatures)		6 Date Shipped (2 Names & Signatures)	
Ex: 32587	4/26/19	4/26/19		5/26/19		5/26/19		5/27/19	
	<i>John Jones</i>	John Jones	<i>John Jones</i>	John Jones	<i>John Jones</i>	John Jones	<i>John Jones</i>	John Jones	<i>John Jones</i>
	<i>John Jones</i>	Sally Smith	<i>Sally Smith</i>	Sally Smith	<i>Sally Smith</i>	Sally Smith	<i>Sally Smith</i>	Sally Smith	<i>Sally Smith</i>

Instructions: Each Inner Liner (container) will bear a permanent, unique identification number to enable tracking on the Inner Liner form. Columns 1 and 2 are to be completed upon receipt of Inner Liner. Column 3 is to be completed upon installation of the container into the collection receptacle. Column 4 is to be completed upon removal of the container from the collection receptacle. Column 5 is to be completed if the Inner Liner is removed from the receptacle and placed in storage before being shipped. Column 6 should be completed when the inner liner is shipped for destruction. Maintain a copy of the completed "Inner Liner form" and other records, as applicable, on file at the collector's registered location for at least 2 years.

The purpose of this form is to document the use of the Inner Liner throughout a collection event. Although proper use of this form is intended to help the collector meet record keeping requirements, requirements may vary based on the registrant location. It is the responsibility of each registered collector to understand and comply with all federal, state and local regulatory requirements pertaining to take-back pharmaceuticals applicable at the collector's registered location. The Inner Liner form is not a DEA Form 41.

XVII. Appendix D: Promotion Material

Sample Education Materials

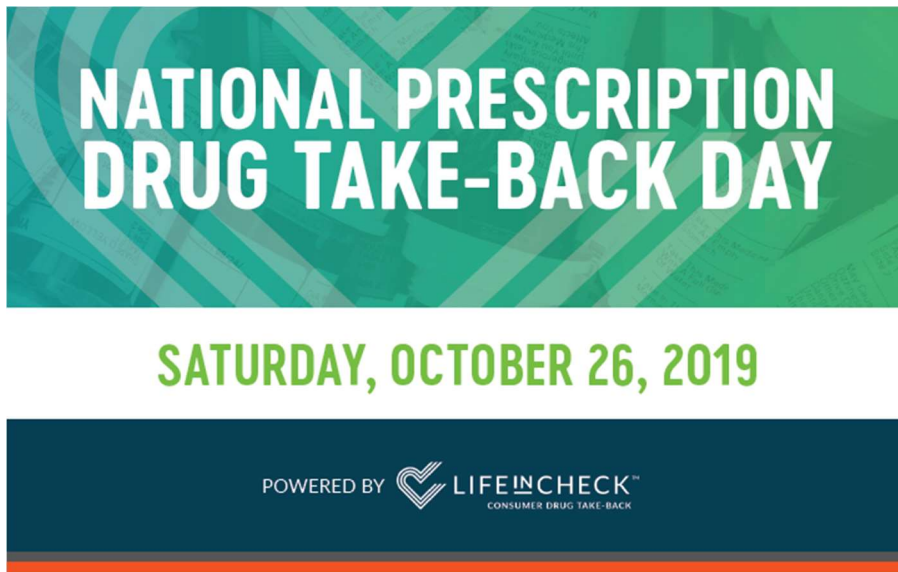

NATIONAL PRESCRIPTION DRUG TAKE-BACK DAY

- Unused or expired prescription medications are a public safety issue, leading to accidental poisoning, overdose, and abuse.
- Pharmaceutical drugs can be just as dangerous as street drugs when taken without a prescription or a doctor's supervision.
- The non-medical use of prescription drugs ranks second only to marijuana as the most common form of drug abuse in America.
- The majority of teenagers abusing prescription drugs get them from family and friends and the home medicine cabinet.
- Unused prescription drugs thrown in the trash can be retrieved and abused or illegally sold. Unused drugs that are flushed contaminate the water supply. Proper disposal of unused drugs saves lives and protects the environment.

TAKE-BACK PROGRAMS ARE THE BEST WAY TO DISPOSE OF OLD DRUGS.

But if a program is not available:

- Take the meds out of their bottles;
- Mix the medicines (do not crush tablets or capsules) with an unpalatable substance such as dirt, kitty litter, or used coffee grounds. This prevents thievery or diversion of medicines from the trash.
- Place the mixture in a container such as a zip-lock or sealable plastic bag, and throw the container away in your household trash.

FOR MORE INFORMATION ON PRESCRIPTION DRUG ABUSE, GO TO:

www.dea.gov
www.getsmartaboutdrugs.com
www.justthinktwice.com





EVERY DAY IS CONSUMER DRUG TAKE-BACK DAY

Working together to protect our families, communities and environment.

GO TO [RXDISPOSAL.LIFEINCHECK.COM](https://rxdisposal.lifeincheck.com) TO FIND A RECEPTACLE NEAR YOU



HOW IT WORKS

- 1 Pull to open drawer**
Hale para abrir el cajón
- 2 Place medications inside**
Coloque las medicinas adentro
- 3 Close the drawer**
Cierre el cajón



SAFELY DISPOSE OF YOUR UNUSED OR EXPIRED MEDICATIONS!

DID YOU KNOW?

192 AMERICANS
die every day from a drug overdose.
*ahr.gov

46 MILLION
people at minimum, in 24 major American metropolitan areas are exposed to pharmaceutical contaminated drinking water.

83% OF PEOPLE
who misuse prescription pain relievers including opioids get them from a friend, relative or others.
*samhsa.gov

Sample Authorized Collector Marketing Support



STOP BY TO SAFELY
DISPOSE OF YOUR
UNUSED OR EXPIRED MEDS

83% OF PEOPLE WHO MISUSE PRESCRIPTION
PAIN RELIEVERS INCLUDING OPIOIDS GET THEM
FROM A FRIEND, RELATIVE OR OTHERS.

(WWW.SAMHSA.GOV)

46 MILLION AMERICANS ARE EXPOSED TO
TRACE AMOUNTS OF MEDICATIONS IN THEIR
DRINKING WATER.

(ASSOCIATED PRESS)



For more information on safe drug storage and disposal, as well
as information on additional collection options,
visit rxdisposal.lifeincheck.com or call 1-800-123-4567

SPONSORED BY LIFEINCHECK

SOCIAL MEDIA

Twitter: Crafting the Perfect Tweet

Twitter is a simple way to quickly share short pieces of information. Twitter posts can be up to 140 characters in length, but 100 characters is the ideal length for maximum distribution. Including images in your tweets will make them stand out in the Twitter feed; these images should be 1084 x 512 pixels*.

Facebook: Appealing to Your Audience

Facebook allows you to share lengthier posts with slightly larger images. However, longer isn't always better. Shorter posts with compelling graphics tend to receive more shares and comments than longer posts, giving you more visibility within the Facebook news feed. Keeping your Facebook posts under 100 characters is ideal. Always include a link to an article or an image. Images on this social media platform are ideally 1200 x 828 pixels.

SAMPLE POSTS

Copy and paste the following social media posts into your Facebook or Twitter to spread the word about the importance of properly managing leftover pharmaceuticals and drive people to your location. You can also combine them with some of the facts below to drive awareness of the importance of consumer drug take-back programs. Be sure to add one of the accompanying images and to fill in your location's name.

Announcing our new Consumer Drug Take-Back program to safely dispose of unused medications at OUR LOCATION.

OUR LOCATION wants to help you protect your loved ones, the community and the environment! Now you can dispose of unused meds here.

OUR LOCATION wants to help you protect your loved ones, the community and the environment by offering free unused meds disposal.

Got leftover meds? Drop them off at OUR LOCATION – free and easy.

Visit OUR LOCATION to drop off your leftover meds for free – no questions asked.

Leaving leftover drugs in the home can pose health and environmental dangers. Safely dispose of them today at OUR LOCATION!

Drop off your unwanted prescription and OTC meds in the green box at OUR LOCATION.

Rid your home of dangerous, leftover meds today. Bring them to OUR LOCATION to dispose of them safely – no questions asked!

Do you have leftover drugs in your medicine cabinet? Now you can dispose of them easily and safely at OUR LOCATION.

Safe prescription drug disposal is easy. Just find the green box in OUR LOCATION.

Do the right thing: don't flush your meds. Return leftover drugs to a safe take-back location like our green box at OUR LOCATION.

Do the right thing: don't flush your meds. Bring them to OUR LOCATION for proper disposal.

Protect your community – bring your leftover meds to a safe drug take-back program like ours at OUR LOCATION.

Help us stop the opioid epidemic. Dispose of your unused meds at OUR LOCATION.

DID YOU KNOW?
192 AMERICANS
 die every day from a drug overdose.*

AT
EVERYDAY IS CONSUMER DRUG TAKE-BACK DAY

Go to rxdisposal.Lifeincheck.com
 to find a receptacle near you

*cdc.gov

LIFE IN CHECK™

SAFELY DISPOSE OF YOUR UNUSED OR EXPIRED MEDICATIONS!

WE ARE PARTICIPATING!

NATIONAL PRESCRIPTION DRUG TAKE-BACK DAY

SATURDAY, OCTOBER 26, 2019

SPONSORED BY LIFE IN CHECK™
CONSUMER DRUG TAKE BACK

SAMPLE PRESS-RELEASE

Use the template included in the press release folder or copy and paste the below to customize your press release and send out to media outlets in your area.

FOR IMMEDIATE RELEASE

CONTACT:
 [insert contact name here]
 [insert contact's title here]
 [phone number]
 [contact or program email address]
[web site url if you have a web site](#)

[insert pharmacy name] announces convenient drug takeback program for leftover household medications

[CITY, STATE, TODAY'S DATE] – [PHARMACY NAME] announced today it has established a convenient medication takeback program for easy disposal of leftover, unused and out-of-date prescription and over-the counter medications.

It is an effort to help reduce the risk of drugs in the home that can potentially harm children, teens or adults. [PHARMACY NAME] has set up a secure, safe drop-off location in its pharmacy at [ADDRESS] in [CITY NAME].

Unused medications in the home are a source of drug abuse in millions of homes, with the opioid crisis in the United States fueled in part by that availability. More than 83 percent of opioid prescription medications taken by new users are obtained from a friend, relative or others. Overall, 192 Americans die every day from a drug overdose.

"We want to provide the folks in our community with the safe, secure opportunity to clean out their medicine cabinets and make their homes and communities safer," said **[NAME OF PHARMACY MANAGER OR OWNER], of [PHARMACY NAME].** "We want to remind people that they should not flush drugs down the toilet. Traces of drugs can appear in community drinking water. Our drug disposal unit, which is easily accessible in the pharmacy, is a great answer to that problem and it's simple to do. All they do is just come in, look for the big green receptacle and take it from there. Drugs can be dropped off with no questions asked."

[PHARMACY MANAGER/OWNER'S LAST NAME] said there are some things that can't be taken in the receptacle, such as inhalers and needles, but pharmacy staff will be on hand to help determine what to do. The collection receptacle will be available in the pharmacy at **[ADDRESS], [DAYS AND HOURS]**

[PHARMACY NAME] partnered with Inmar to manage this drug take back program. The company has a long history as the industry leader in handling prescription and over-the-counter drug returns safely, securely and discreetly for major and regional chain drug stores as well as independent pharmacies and hospitals across the U.S.

Sample Social Influencer Content

"Recovery Is Possible + An Easy Way You Can Help Fight The Opioid Epidemic"

By It's a Fabulous Life



<http://itsafabulouslife.com/recovery-is-possible-an-easy-way-you-can-help-fight-the-opioid-epidemic/>

MOM UNLEASHED

HOME COOK CREATE EXPERIENCE INSPIRE

EASY WAYS TO KEEP PRESCRIPTION DRUGS SAFE: 3 SIMPLE STEPS EVERY PARENT SHOULD TAKE TODAY



I'll be honest, I've always been a worrier. Even as my kids get older, it's not at all uncommon for me to take looks at my home and find ways to safeguard the dangers that I see for not only my children but my entire family. Ever since the news that it's become more of a priority as the opioid crisis has risen and there have been more and more cases of children and adults alike not only getting their hands on prescriptions but selling and buying them. Of course I trust my kids and I know that they know the dangers of prescription drugs but as a parent, that does not absolve me from my task of making my home the safest place possible. That's why, in honor of April 27th 2020 being National Prescription Drug Take Back Day, I've been researching the way that I look at prescription drugs in my home and coming up with easy ways to keep prescription drugs safe.



Moments in time capturing, forming, the adventures of a Mom and sharing the benefits and fun in just one hour. Please stop in the link provided or other sites listed for deals and more on each side of parenting and home!

LifeInCheck

April 10 at 2:55 PM

Spring is the perfect time to declutter your space & dispose of unused or expired items. Follow these tips!



5 Easy Tips To Declutter Your Closet & Medicine Cabinet

What's the oldest date in your medicine cabinet?

135 11 Comments 88 Shares

Like Comment Share

*Geo-targeted ads to store list zip codes and interest targeted ads to key terms such as: caregiver, home care, nursing, nursing home care, pharmacy, substance abuse prevention, rehabilitation hospitals, environmentalism, social responsibility, environmental protection, and social movements

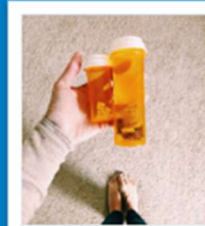

XVIII. Appendix E: Applicable Permits and Licenses

Permits, Licenses and requested enforcement action information is provided on the following pages.

DEA REGISTRATION NUMBER	THIS REGISTRATION EXPIRES	FEE PAID
R90571364	04-30-2023	\$1850
SCHEDULES	BUSINESS ACTIVITY	ISSUE DATE
1,2,2N, 3,3N,4,5	REVERSE DISTRIB-COLLECTOR	04-29-2022
123 COMPLIANT LOGISTICS, LLC 2626 N 29TH AVE PHOENIX, AZ 850091602		

CONTROLLED SUBSTANCE REGISTRATION CERTIFICATE
 UNITED STATES DEPARTMENT OF JUSTICE
 DRUG ENFORCEMENT ADMINISTRATION
 WASHINGTON D.C. 20537

Sections 304 and 1008 (21 USC 824 and 958) of the Controlled Substances Act of 1970, as amended, provide that the Attorney General may revoke or suspend a registration to manufacture, distribute, dispense, import or export a controlled substance.

THIS CERTIFICATE IS NOT TRANSFERABLE ON CHANGE OF OWNERSHIP, CONTROL, LOCATION, OR BUSINESS ACTIVITY, AND IT IS NOT VALID AFTER THE EXPIRATION DATE.

CONTROLLED SUBSTANCE REGISTRATION CERTIFICATE
 UNITED STATES DEPARTMENT OF JUSTICE
 DRUG ENFORCEMENT ADMINISTRATION
 WASHINGTON D.C. 20537

DEA REGISTRATION NUMBER	THIS REGISTRATION EXPIRES	FEE PAID
R90571364	04-30-2023	\$1850
SCHEDULES	BUSINESS ACTIVITY	ISSUE DATE
1,2,2N, 3,3N,4,5	REVERSE DISTRIB-COLLECTOR	04-29-2022
123 COMPLIANT LOGISTICS, LLC 2626 N 29TH AVE PHOENIX, AZ 850091602		

Sections 304 and 1008 (21 USC 824 and 958) of the Controlled Substances Act of 1970, as amended, provide that the Attorney General may revoke or suspend a registration to manufacture, distribute, dispense, import or export a controlled substance.

THIS CERTIFICATE IS NOT TRANSFERABLE ON CHANGE OF OWNERSHIP, CONTROL, LOCATION, OR BUSINESS ACTIVITY, AND IT IS NOT VALID AFTER THE EXPIRATION DATE.

TransChem Environmental
542 E. 27th Street
Tucson, AZ 85713
520-829-5651

8-Dec-21

Record of any penalties, violations or regulatory orders received in the previous five (5) years.

Penalties

Date of Penalty	Description of Penalty	Fine Y/N	Amount of Fine	Remedy

Violations

Date of Violation	Description of Violation	Fine Y/N	Amount of Fine	Remedy

Regulatory Orders

Date of Order	Description of Order	Fine Y/N	Amount of Fine	Remedy

[Handwritten Signature]
12-8-21

TransChem Environmental has no violations, penalties or regulatory orders in the past 5 years.

Enforcement Action Summary Report

Facility *Aragonite*

<i>Date Received</i>	<i>Agency</i>	<i>Enforcement Type</i>	<i>Alleged Violation</i>	<i>Proposed Penalty</i>	<i>Status</i>	<i>Resolution Date</i>	<i>Penalty Paid</i>
10/20/2016	UDEQ	Notice of Violation	1) Storage facility for water supply had a leak at the time of inspection, 2) the public water supply storage vessel showed signs of a leak.	\$0.00	Resolved w/o Penalty	12/14/2016	\$0.00
		<i>EA Number:</i>	<i>Description of Resolution:</i>	Repaired the tanks.			
2/8/2017	UDEQ - DDW	Notice of Violation	Failure to monitor and report for pesticides and volatile organic compounds in 2016.	\$0.00	Resolved w/o Penalty	2/15/2017	\$0.00
		<i>EA Number:</i>	<i>Description of Resolution:</i>	Updated testing was conducted.			
5/16/2018	UDEQ - Division of Air Quality	Notice of Violation	Failure to submit stack test results, deviation reports, leak detection and repair reports, Benzene NESHAP reports, semi-annual reports and compliance certifications in a timely manner.	\$23,750.00	Resolved	5/21/2018	\$23,750.00
		<i>EA Number:</i>	<i>Description of Resolution:</i>				

1/28/2019	US DEA	Notice of Violation	1) Failure to file annual inventory, 2) delinquent filing of quarterly ARCOS reports, failure to maintain a separate file for Schedule 1 and 2 and Schedule 3 through five controlled substances, 4) failure to record time of annual inventory.	\$120,000.00	Resolved	5/8/2019	\$96,000.00
-----------	--------	---------------------	--	--------------	----------	----------	-------------

EA Number:

Description of Resolution:

Payment of a civil penalty.

9/26/2019	Utah Department of Commerce	Penalty Notice	Failure to report to the division any adverse action taken by another licensing jurisdiction.	\$300.00	Resolved	10/10/2019	\$300.00
-----------	-----------------------------	----------------	---	----------	----------	------------	----------

EA Number:

Description of Resolution:

Paid civil penalty

1/23/2020	UDEQ	Compliance Advisory	The facility's Public Water System rating is expected to be downgraded for the following deficiencies: 1) area within 50 feet of a storage tank not graded to prevent standing water, 2) lack of an approved DWSP plan at two locations.	\$0.00	Pending		\$0.00
-----------	------	---------------------	--	--------	---------	--	--------

EA Number:

Description of Resolution:

4/8/2020	UDEQ	Notice of Violation	29 alleged violations resulting from the annual inspection conducted in the Fall 2019.	\$106,840.00	Pending		\$0.00
----------	------	---------------------	--	--------------	---------	--	--------

EA Number:

2001004

Description of Resolution:

7/15/2020	Alabama Board of Pharmacy	Consent Administrative Order	1) Conducting operations in the State but failing to timely renew a permit, 2) Failure to conduct business in accordance with the State rules because of violations settled with the US DEA in January 2019.	\$10,000.00	Resolved	8/10/2020	\$10,000.00
-----------	---------------------------	------------------------------	--	-------------	----------	-----------	-------------

EA Number: 19-L-0162 *Description of Resolution:* Paid a civil penalty.

8/31/2020	US EPA	Warning Letter/Notice	Incineration of materials in violation of the prohibition on dilution of certain hazardous wastes by incineration.	\$0.00	Pending		\$0.00
-----------	--------	-----------------------	--	--------	---------	--	--------

EA Number: *Description of Resolution:*

12/9/2020	Alabama Board of Pharmacy	Compliant	1) Failure to disclose an enforcement action in another jurisdiction on a permit application and applicable Alabama Board of Pharmacy rules violations from lack of disclosure.	\$2,000.00	Resolved	2/24/2021	\$2,000.00
-----------	---------------------------	-----------	---	------------	----------	-----------	------------

EA Number: 20-L-0097 *Description of Resolution:* Paid an administrative penalty.

12/15/2020	Arizona Board of Pharmacy	Penalty Notice	Failure to notify the Board of a prior enforcement action in another jurisdiction.	\$250.00	Resolved	1/26/2021	\$250.00
------------	---------------------------	----------------	--	----------	----------	-----------	----------

EA Number: *Description of Resolution:* Entered into a consent order.

1/15/2021	US EPA	Warning Letter/Notice	1) Failure to monitor emissions from the Corrosives Unit, Blended Waste Feed, Aqueous Waste Feed, and Sludge Waste Feed operation, 2) 24 open ended valves on the carbon system, 3) a rupture disk operating above the no detectable emissions standard, 4) Failure to record the date of first repair attempt, 5) Excess emissions from 12 pressure relief devices and 5 connectors, 6) Failing to record information on equipment tagged for repair, 7) Storing light liquid material in containers that had leaks, 8) Failure to adequately train employees to conduct Method 21 monitoring, 9) Failure to use equipment that adequately monitors for Method 21, 10) Failure to repair 3 pieces of equipment in 15 days.	\$470,000.00	Pending	\$0.00
-----------	--------	-----------------------	---	--------------	---------	--------

EA Number:

Description of Resolution:

2/26/2021	Bureau of Alcohol, Tobacco and Fire Arms	Warning Letter/Notice	Failure to timely/accurately enter all required explosive inventory identification and quantity information in a daily summary of magazine transaction (per magazine)	\$0.00	Resolved w/o Penalty	2/26/2021	\$0.00
-----------	--	-----------------------	---	--------	----------------------	-----------	--------

EA Number:

Description of Resolution:

Provided corrective actions to the Agency.

3/26/2021	UDEQ	Notice of Violation	12 alleged violations related to permit conditions on waste storage conditions, timing, training and rejection procedures identified during the 2020 annual inspection.	\$0.00	Pending	\$0.00
-----------	------	---------------------	---	--------	---------	--------

EA Number:

NOV 2102003

Description of Resolution:

Enforcement Action Summary Report

Facility *El Dorado*

<i>Date Recieved</i>	<i>Agency</i>	<i>Enforcement Type</i>	<i>Alleged Violation</i>	<i>Proposed Penalty</i>	<i>Status</i>	<i>Resolution Date</i>	<i>Penalty Paid</i>
3/14/2019	ADEQ	Notice of Violation	1) Allowing water to remain in secondary containment longer than 24 hours, thus impeding the ability to monitor for leaks, 2) failure to properly document inspections for secondary containment.	\$8,000.00	Resolved	5/17/2019	\$8,000.00
			<i>EA Number:</i> LIS 19-048	<i>Description of Resolution:</i>	Entered into the administrative consent order.		
11/21/2019	ADEQ	Notice of Violation	1) Opacity issues at kiln 1, 2) Opacity issues at kiln 2 and 3) Open diverts at kiln 2 require additional explanation to the air regulators.	\$10,020.00	Resolved		\$6,513.00
			<i>EA Number:</i> LIS 21-120	<i>Description of Resolution:</i>	Paid a civil penalty and provided ergonomic hose reloading equipment to the El Dorado fire department.		
12/9/2019	Delaware Dept. of Natural Resources	Notice of Violation	Failure to provide the Department of Natural Resources with facility copies of infectious waste manifests received from Delaware generators.	\$0.00	Resolved w/o Penalty	1/8/2020	\$0.00
			<i>EA Number:</i> 19-SW-43	<i>Description of Resolution:</i>	Supplied the required manifests.		

8/25/2020	ADEQ	Warning Letter/Notice	Discharge exceedance of the effluent limitation for Mercury at the 007 outfall during the 2nd Quarter of 2020.	\$0.00	Pending		\$0.00
-----------	------	-----------------------	--	--------	---------	--	--------

EA Number:

Description of Resolution:

8/31/2020	US EPA	Warning Letter/Notice	Incineration of materials in violation of the prohibition on dilution of certain hazardous wastes by incineration.	\$0.00	Pending		\$0.00
-----------	--------	-----------------------	--	--------	---------	--	--------

EA Number:

Description of Resolution:

10/22/2020	ADEQ	Warning Letter/Notice	Mercury stormwater exceedance.	\$0.00	Pending		\$0.00
------------	------	-----------------------	--------------------------------	--------	---------	--	--------

EA Number:

Description of Resolution:

2/11/2021	FRA	Notice of Non-Compliance	A rail car not sealed appropriately because the bolts on the manway were not tool tight.	\$5,000.00	Resolved	3/11/2021	\$4,000.00
-----------	-----	--------------------------	--	------------	----------	-----------	------------

EA Number:

FRA No. ZCED 2020-1(HMT)

Description of Resolution:

Paid civil penalty.

2/19/2021	FRA	Notice of Non-Compliance	Bolts on a rail car manway were not tool tight.	\$2,000.00	Resolved	3/11/2021	\$1,500.00
-----------	-----	--------------------------	---	------------	----------	-----------	------------

EA Number:

FRA No. ZCED 2020-2(HMT)

Description of Resolution:

Paid civil penalty.

3/30/2021	ADEQ	Notice of Violation	1) Storage of rejected explosives while waiting to obtain transportation permits to remove them from the site.	\$0.00	Dismissed	5/25/2021	\$0.00
-----------	------	---------------------	--	--------	-----------	-----------	--------

EA Number:

Description of Resolution:

Arkansas DEQ withdrew the alleged violation due to extenuating circumstances.

**VEOLIA ES TECHNICAL SOLUTIONS, L.L.C.
PORT ARTHUR, TX**

Inspection Date	Type of inspection	Name of inspector and Regulatory Agency	Alleged Violations	VEOLIA Responses and/or Corrective Actions Taken
2/15/2017	ATF		No Violations	
3/9/2017	CAA	TCEQ	<p>Alleged Violations:</p> <p>1.) Failure to maintain the Carbon Monoxide incinerator.</p> <p>2.) Failure to maintain Carbon Monoxide emissions of 100 parts per million by volume (ppmv) at the incinerator.</p> <p>3.) Failure to maintain incinerator minimum combustion temperatures.</p> <p>4.) Failure to maintain Arsenic and Chormium emission rates at the Incinerator.</p> <p>5.) Failure to maintain combined Cadmium-Lead and combined Arsenic-Beryllium-Chromium emissions at the Incinerator.</p> <p>6.) Failure to maintain the Carbon Monoxide emission rate of 17.10 pounds per hour during start-up at the Incinerator.</p>	<p>4/18/2017 Received NOV</p> <p>5/27/2017 Submitted Corrective Action Plan</p> <p>9/29/2017 Received a letter from the TCEQ stating adequate compliance documentation was received and no further action required</p>
6/15/2017	TPDES	TCEQ	No Violations - Three Areas of Concern	8/9/2017 Received a letter from the TCEQ stating no violations are alleged.
2/22/2018	OPCC	TCEQ	<p>Alleged Violations</p> <p>1.) Failure to maintain the CO emission rate at the Incinerator.</p> <p>2.) Failure to limit Carbon Monoxide concentration at 100 parts per million by volume (ppmv) at the</p> <p>3.) Failure to maintain Incinerator minimum combustion temperatures.</p> <p>4.) Failure to maintain Beryllium, Selenium, and Chromium emission rates at the Incinerator.</p>	<p>4/26/2018 Received Notice of Violation.</p> <p>5/25/2018 Submitted a Response to NOV.</p> <p>10/15/2018 Received a letter from TCEQ stating no further action required.</p>

**VEOLIA ES TECHNICAL SOLUTIONS, L.L.C.
PORT ARTHUR, TX**

Inspection Date	Type of inspection	Name of inspector and Regulatory Agency	Alleged Violations	VEOLIA Responses and/or Corrective Actions Taken
			<p>5.) Failure to limit combined Arsenic-Beryllim-Chromium emissions at the Incinerator.</p> <p>6.) Failure to maintain Mercury emission rates at the Incinerator.</p> <p>7.) Failure to limit Mercury emissions at the Incineraotr.</p> <p>8.) Failure to maintain the Hazardous Wsate Permit miminum voltage requirements at the Ionizing Wet Scrubber.</p> <p>9.) Failure to maintain EPA and Hazardous Waste Permit minimum voltage requirments at the Ionizing Wet Scrubber (IWS) equipment.</p>	
6/13-21/2018	RCRA	TCEQ	<p>Alleged Violations</p> <p>1.) Failure to maintain inspection records as required by permit.</p> <p>2.) Failure to Maintain aisle space to allow unobstructed movement of personnel and emergency response equipment.</p> <p>Additional Issues</p> <p>3.) A concern the regulated entity may not be meeting the requirements of properly maintaining an accuarate storage inventory amount.</p> <p>4.) The concern is the regulated entity may not be meeting the requirements of properly storing incompatible waste.</p>	<p>9/21/2018 Submitted a response to TCEQ.</p> <p>1/4/2019 Received Letter from TCEQ stating no further action required.</p>

**VEOLIA ES TECHNICAL SOLUTIONS, L.L.C.
PORT ARTHUR, TX**

Inspection Date	Type of inspection	Name of inspector and Regulatory Agency	Alleged Violations	VEOLIA Responses and/or Corrective Actions Taken
7/18/2018	Transportation Ten Day Yard	TCEQ	No Issues Found	
			1.) Paperwork Error on the Chain of Custody	10/19/2018 Posted required public notice in all Veolia Port Arthur Buildings 10/22/2018 Submitted copy of Monitoring Violation Public Notice and Certificate of Delivery to TCEQ. No further action required.
1/17/2019	CAA	TCEQ	<p>Alleged Violations</p> <p>1.) Failure to maintain tons per year emissions for permitted sources on a 12 month rolling period basis.</p> <p>2.) Failure to maintain the Hazardous Waste Permit minimum voltage requirements at the Ionizing Wet Scrubber (IWS) equipment.</p> <p>3.) Failure to comply with the EPA and the Hazardous Waste Permit minimum voltage requirements at the Ionizing Wet Scrubber (IWS) equipment.</p> <p>4.) Failure to comply with the EPA minimum kilovolts-amps requirement at the Wet Electrostatic Precipitator (WESP).</p> <p>5.) Failure to maintain the CO emission rate at the Incinerator (EPN INCINSTK).</p> <p>6.) Failure to limit Carbon Monoxide concentration to 100 parts per million by volume (ppmv) at the Incinerator.</p> <p>7.) Failure to maintain Incinerator minimum combustion temperatures.</p>	<p>3/18/2019 Received NOV letter</p> <p>4/25/2019 Submitted Corrective Action Plan</p> <p>10/1/2019 Received letter from TCEQ stating no further action required.</p>

**VEOLIA ES TECHNICAL SOLUTIONS, L.L.C.
PORT ARTHUR, TX**

Inspection Date	Type of inspection	Name of inspector and Regulatory Agency	Alleged Violations	VEOLIA Responses and/or Corrective Actions Taken
			8.) Failure to certify the Permit Compliance Certification. 9.) Failure to report all instances of deviations.	
6/25/2019	LQG/UIC/Ten day facility	TCEQ	No Alleged Violations	8/1/2019 Received Letter from TCEQ stating no violations are being alleged.
12/16/2019	DEA	DEA	DEA controlled substances inventory was not conducted. No DEA controlled substances were present at the Veolia site at the time.	1/17/2020 Veolia submitted a formal biennial inventory of controlled substances to the DEA. The inventory was zero(0).
1/22/2020	Foreign Soil Permit	USDEA	No Alleged Violations	
2/14/2020	TSD/LQG/Used Oil	TCEQ	Alleged Violations 1.) Failure to follow the Waste Analysis Plan 2.) Failure to separator protect storage containers holding hazardous waste that is incompatible with any waste or other material stored nearby in other containers. 3.) Failure to provide the hazardous waste accumulation (>1 year) was solely for the purpose of holding of such quantities of hazardous waste as are necessary to facilitate proper disposal. 4.) Failure to post the "TCEQ Permit Unit No. _" sign at the permitted facility unit. 5.) Failure to maintain disposal records for the disposal of waste oil. 6.) Failure to maintain adequate (e.g., include inspector's full name and time of inspection) monthly safety inspection records (e.g., fire extinguishers, first aid	6/12/2020 Received NOV Letter 7/15/2020 Submitted Corrective Action Plan to TCEQ. 10/26/2020 Received No Further Action Letter

**VEOLIA ES TECHNICAL SOLUTIONS, L.L.C.
PORT ARTHUR, TX**

Inspection Date	Type of inspection	Name of inspector and Regulatory Agency	Alleged Violations	VEOLIA Responses and/or Corrective Actions Taken
			<p>kits, Self-Contained Breathing Apparatus (SCBA), showers, and Table III.E.3. - Emergency Equipment of the Contingency Plan) for a period of 3 years. records of the Protective Gear Designated for Emergency Use.</p> <p>8.) Failure to maintain the date and nature of any repairs or other remedial actions documented on the weekly Container Storage Areas inspections.</p> <p>9.) Failure to follow a written schedule for inspecting security devices.</p>	
2/14/2020	UIC	TCEQ	No Alleged Violations	
2/14/2020	Transfer Facility Compliance	TCEQ	No Alleged Violations	3/2/2020 Received letter from the TCEQ stating no alleged violations.
2/26/2020	Public Drinking Water	TCEQ	<p>Alleged Violation</p> <p>1.) Failure to perform maintenance and housekeeping practices used by a PWS to ensure the good working condition and general appearance of the systems' facilities and equipment.</p> <p>Area of Concern</p> <p>1.) Failure to have a complete and up-to-date monitoring plan.</p>	<p>6/29/2020 Received NOV letter from TCEQ.</p> <p>7/22/2020 Submitted Corrective Action Plan to TCEQ.</p> <p>11/24/2020 Received letter from TCEQ stating no further action required.</p>
3/2/2020	OPCC	TCEQ	<p>Alleged Violations</p> <p>1. -3.) Failure to comply with the EPA and the Hazardous Waste Permit minimum voltage requirements at the Ionizing Wet Scrubber (IWS)</p>	<p>6/9/2020 Received NOV letter</p> <p>7/8/2020 Submitted Corrective Actin Plan to TCEQ.</p> <p>10/20/2020 Received letter from TCEQ stating no further action required.</p>

**VEOLIA ES TECHNICAL SOLUTIONS, L.L.C.
PORT ARTHUR, TX**

Inspection Date	Type of inspection	Name of inspector and Regulatory Agency	Alleged Violations	VEOLIA Responses and/or Corrective Actions Taken
			<p>equipment.</p> <p>4.) Failure to maintain the CO emission rate of 17.10 pounds per hour at the Incinerator (EPN INCINSTK).</p> <p>to 100 parts per million by volume (ppmv) at the Incinerator.</p> <p>6. - 7.) Failure to maintain Incinerator minimum combustion temperatures.</p> <p>8.) Failure to comply with the EPA minimum kilovolts-amps requirement at the Wet Electrostatic Precipitator (WESP).</p> <p>9.) Failure to conduct leak detection and repair monitoring.</p>	
8/4/2020	Wastewater	TCEQ	<p>Alleged Violations</p> <p>1.) Failure to report any effluent violation that deviates from the permitted effluent limitation by more than 40% to the Regional office and the Enforcement Division within five working days of becoming aware of the noncompliance. The noncompliance occurred in September 2019.</p>	<p>8/7/2020 Submitted noncompliance notifications to the TCEQ.</p> <p>9/30/2020 Received letter from TCEQ stating no further action required.</p>
12/11/2020	RCRA	TCEQ	No Violations	
1/6-8/2021	ATF		No Violations	
1/11/2021	OPCC	TCEQ	<p><u>Alleged Violations - NOV</u></p> <p>1.) Failure to maintain an emission rate below the</p>	<p>1/27/2021 Received Notice of Violation</p> <p>1/27/2021 Received Notice of Enforcement</p>

**VEOLIA ES TECHNICAL SOLUTIONS, L.L.C.
PORT ARTHUR, TX**

Inspection Date	Type of inspection	Name of inspector and Regulatory Agency	Alleged Violations	VEOLIA Responses and/or Corrective Actions Taken
			<p>allowable Carbon Monoxide (CO) emission limits of 17.1 pounds per hour (lbs/hr) from Emission Point Number (EPN) INCINSTK.</p> <p>2.) Failure to maintain the CO gas concentration below 100 parts per million by volume (ppmv) at the EPN INCINSTK.</p> <p>3.) Failure to maintain the EPA and the Hazardous Waste Permit minimum voltae of 10 kilovolts at the Ionizing Wet Scrubber (IWS) equipment.</p> <p>4.) Failure to maintain the EPA minimum kilovolts-amps requirement of 15.8 kVA at the Wet Electrostatic Precipitator (WESP).</p> <p>5.) Failure to comply with the EPA and the Hazardous Waste Permit minimum voltage requirements at the Ionizing Wet Scrubber (IWS) equipment.</p> <p><u>Violations - NOE</u></p> <p>1.) Failure to maintain emissions below the allowable Caron monoxide (CO) emission limit of 17.1 lbs/hr from EPN INCINSTK.</p>	<p>2/3/2021 Submitted a request to reconsider Enforcement based on significant improvements over the past three years.</p> <p>4/16/2021 Received Proposed Agreed Order</p> <p>7/13/2021 Submitted a signed agreement order and penalty payment of \$3,420.</p>

11/9-10/2021	RCRA	TCEQ	<p>Alleged Violations</p> <p>1.) The investigator observed three Waste Determination records which have been marked incorrectly, in a manner which indicated the wastes would be hazardous and these wastes were Industrial Class 1 and Class 2. The waste determinations were corrected.</p>	
--------------	------	------	---	--

VEOLIA ES TECHNICAL SOLUTIONS, L.L.C.
PORT ARTHUR, TX

Inspection Date	Type of inspection	Name of inspector and Regulatory Agency	Alleged Violations	VEOLIA Responses and/or Corrective Actions Taken
			2.) Failure to place a Waste Stream Identification/ classification of the waste on Manifest 001968617VES	

Received Date	Incident Id	Media	Facility	Agency	Action	Incident Title	Monetary Fine	Description	Follow Up Action	Response Due Date	Status
1/28/2022	MAR-00674	Air	Marion	ODEQ	NOV	Notice of Civil Penalty Assessment and Order	15722	Exceeded non-emergency operating for the emergency fire pump and CO excess emission event.	Penalty paid.		Closed



Wendy Janney <wendy.janney@inmar.com>

[EXTERNAL] FW: 5 year Compliance history

Griffith, Leslie <LGriffith@covanta.com>
To: Wendy Janney <wendy.janney@inmar.com>

Fri, Jun 10, 2022 at 1:04 AM

Indianapolis and Manheim RDC 5 year compliance report.

Leslie Griffith

Director of Business Development



CES Healthcare Solutions

445 South Street

Morristown, NJ 07960

Tel: 862.222.5792

Email: LGriffith@covanta.com

<http://covantaenvironmental.com/>

Our mission is to ensure no waste is ever wasted.



From: Frotton, John <JFrotton@covanta.com>
Sent: Thursday, June 9, 2022 2:32 PM
To: Walsh, Pat <PWalsh@covanta.com>; Griffith, Leslie <LGriffith@covanta.com>
Subject: RDC 5 year Compliance history

There are no enforcement actions in the last 5 yrs at either HRDC , so there is no report for them

Respectfully,



John Frotton

Director of Material Profiling

Mobile: 973-722-3892

Our mission is to ensure no waste is ever wasted.

CONFIDENTIALITY AND PRIVACY NOTICE: Information transmitted in this email is proprietary to Covanta and is intended for use only by the individual or entity to which it is addressed. It may contain information that is private, privileged, confidential or exempt from disclosure under applicable law. If you are not the intended recipient or it appears that this mail has been forwarded to you without proper authority, you are notified that any use or dissemination of this information in any manner is strictly prohibited. In such cases, please inform the sender and delete this mail from your records.



Compliance History

September 2016 – April 2022

Agency	Inspection Date / Other	Summary of Results
Ohio EPA DERR, Hazardous Waste Management	November 19, 22-24, 2021	Semi-Annual Compliance Evaluation Inspection (CEI), in person and virtual site inspection.. The inspection resulted in two (2) violations that were abated at the time of the inspection: one 5-gallon satellite container was open; and there was inadequate aisle space at one storage location. There are no outstanding violations.
Ohio EPA DERR, Hazardous Waste Management	October 6, 2021	Ohio EPA approval of a Specific Trial Technology Request (“STTR”) for a scrubber water treatment technology.
Ohio EPA Division of Air Pollution Control	August 24, 2021	On August 24, 2021, the OEPA DAPC conducted an air inspection of the Facility. No violations were found.
Ohio EPA DERR, Hazardous Waste Management	July 9, 2021	Informal Compliance Inspection/Walk Through.
Ohio EPA DERR, Hazardous Waste Management	June 4, 2021	Groundwater Report Compliance Review. No violations were found.
Ohio EPA DERR, Hazardous Waste Management	April 29, 2021	RIS voluntarily disclosed an instance of noncompliance. RIS deviated from fingerprint sampling process in accordance with its Waste Analysis Plan (WAP). Upon discovery, RIS revised procedures and re-trained employees to address this violation.
Ohio EPA DERR, Hazardous Waste Management	November 18-20, 2020	Semi-Annual CEI, virtual site inspection.. No violations were found.
Ohio EPA DERR, Hazardous Waste Management	July 21 – July 23, 2020	Semi-Annual CEI, virtual site inspection. No violations were found.
Ohio EPA DERR, Hazardous Waste Management	July 13, 2020	Focused Compliance Inspection (FCI) of Post-Closure areas, virtual site inspection. No violations were found.
Ohio EPA DERR, Hazardous Waste Management	June 4, 2020	RIS submitted its Waste Minimization Report/Plan. No violations were found.
Ohio EPA Division of Air Pollution Control	May 22, 2020	RIS submitted a Relative Accuracy Test Audit (RATA) of its Continuous Emissions Monitoring (CEM) system.
Ohio EPA DERR, Hazardous Waste Management	April 24, 2020	RIS voluntarily disclosed an instance of noncompliance. RIS deviated from visual inspection and fingerprint sampling process in accordance with its Waste Analysis Plan (WAP). Upon discovery, RIS revised procedures and re-trained employees to address this violation.
Ohio EPA DERR, Hazardous Waste Management	March 30, 2020	Groundwater Report Compliance Review and Non-Financial Records Review. No violations were found.
Ohio EPA Division of Air Pollution Control	January 31, 2020	RIS voluntarily disclosed an instance of noncompliance in Title V Quarterly Report pertaining to discharge of combustion gases emitted to the atmosphere that contain carbon monoxide in excess of RIS hourly rolling average.
Ohio EPA Division of Environmental Response and Revitalization (“DERR”), Hazardous Waste Management	November 14, 2019	FCI. No violations were found.
Ohio EPA DERR, Hazardous Waste Management	October 23, 2019	RIS voluntarily disclosed an instance of noncompliance related to waste storage. RIS stored a container for longer than its permit limits. It was also noted that the container was not inspected at the expected permitted frequency. The container was treated upon its discovery. In addition, RIS did not follow visual inspection and fingerprint sampling in accordance with its WAP. Upon discovery, RIS revised procedures and re-trained employees to address this violation.
Ohio EPA DERR, Hazardous Waste Management	September 9, 10, and 11 2019	Semi-Annual CEI. Two (2) violations were noted related to container management. Violations were abated at the time of the inspection.
Ohio EPA DERR, Hazardous Waste Management	July 30, 2019	Groundwater Report Compliance Review. No violations were found.
Ohio EPA Division of Air Pollution Control	July 24, 2019	On July 24, 2019, the OEPA DAPC conducted an air inspection of the Facility. No violations were found.



Compliance History

September 2016 – April 2022

Agency	Inspection Date / Other	Summary of Results
Ohio EPA DERR, Hazardous Waste Management	June 18, 2019	FCI. Three (3) violations were noted related to container management. Violations were abated at the time of the inspection.
Ohio EPA Division of Air Pollution Control	May 8, 2019	RIS submitted the results of a Confirmatory Performance Test (CfPT) and Notice of Compliance with its Title V permit.
U.S. EPA, Division of Air Pollution Control	May 7, 2019	U.S. EPA conducted an inspection related to SubPart BB, CC permitted activities in tanks. In July 2020, RIS received correspondence from the May 2019 inspection. U.S. EPA proposed a Finding of Violation (“FOV”). Discussions are continuing between RIS and U.S. EPA.
Ohio EPA Division of Air Pollution Control	April 30, 2019	RIS submitted a RATA of its CEM system.
Ohio EPA DERR, Hazardous Waste Management	March 12, 13, and 14, 2019	Semi-Annual CEI. One violation was noted related to container management. The violation was abated at the time of the inspection.
Ohio EPA DERR, Hazardous Waste Management	March 5, 2019	RIS requested a 120-day extension to the Director’s Findings and Orders issued on December 5 th . On March 5 th the Director of Ohio EPA granted RIS permission to extend the December 5 th Orders for 120-days.
Ohio EPA DERR, Hazardous Waste Management	December 27, 2018	RIS voluntarily disclosed an instance of noncompliance related to waste storage. One cubic yard container was sampled and visually inspected as required by RIS’ WAP. However, the container began leaking. The container, including absorbents (e.g. spill pigs, floor dry, saw dust) used to cleanup any liquids, was overpacked and subsequently burned as on-site generated waste. As such, the generated debris caused the original waste to meet 40 CFR 268.3 requirements.
Ohio EPA DERR, Hazardous Waste Management	November 16, 2018	FCI. Four violations were noted related to container management. Violations were abated at the time of the inspection.
Ohio EPA DERR, Hazardous Waste Management	November 1, 2018	Groundwater Report Compliance Review. No violations were found.
Ohio EPA DERR, Hazardous Waste Management	September 10, 11 and 12, 2018	Semi-Annual CEI. No violations were found.
Ohio EPA DERR, Hazardous Waste Management	August 27, 2018 / December 5, 2018	RIS voluntarily disclosed an instance of noncompliance related to waste storage. The non-compliance was resolved prior to disclosure. Subsequently, RIS requested and was granted by the Director of Ohio EPA (Director’s Findings and Orders) permission to temporarily store hazardous waste in vans for 90-days. In December 2018, Ohio EPA issued a Director’s Final Findings and Orders that set forth a schedule for compliance.
Ohio EPA DERR, Hazardous Waste Management	August 16, 2018	RIS voluntarily disclosed an emergency push at its incinerator. Specifically, on July 29, 2018, a plastic pail lid blew off in the staging area of CSF. The pail, which had just been unloaded from a van and set aside along with two other pails of the same waste, subsequently caught fire. An Emergency Coordinator (EC) was notified immediately. The EC decided to immediately process the waste. The remaining two pails had evidence of pressure and were also processed immediately.
Ohio EPA DERR, Hazardous Waste Management	June 25, 2018	FCI. One violation was noted related to container management. The violation was abated at the time of the inspection.
Ohio EPA Division of Air Pollution Control	May 25, 2018	RIS voluntarily disclosed an instance of noncompliance in Title V Quarterly Report pertaining to discharge of combustion gases to be emitted into the atmosphere that contain carbon monoxide in excess of RIS hourly rolling average.
Ohio EPA Division of Environmental Response and Revitalization	March 12, 13 and 14, 2018	Semi-Annual CEI. One violation was noted related to container management. The violation was abated at the time of the inspection.
Ohio EPA Division of Air Pollution Control	February 12, 2018	RIS voluntarily disclosed an instance of noncompliance in Title V Quarterly Report pertaining to discharge of combustion gases to be emitted into the atmosphere that contain carbon monoxide in excess of RIS hourly rolling average.
Ohio EPA DERR, Hazardous Waste Management	November 14, 2017	FCI. Two violations were noted related to container management. Violations were abated at the time of the inspection, or shortly thereafter.



Compliance History

September 2016 – April 2022

Agency	Inspection Date / Other	Summary of Results
Ohio EPA DERR, Hazardous Waste Management	September 6 and September 7, 2017	Semi-Annual CEI. No violations were found.
Ohio EPA Division of Air Pollution Control	May 24, 2017	On May 24, 2017, the OEPA DAPC conducted an air inspection of the Facility. No violations were found.
Ohio EPA Division of Materials and Waste Management	May 18, 2017	Post-Closure Compliance Inspection. No violations were found.
Ohio EPA Division of Materials and Waste Management	March 13 and March 16, 2017	Semi-Annual CEI. Two violations were noted related to container management. Violations were abated at the time of the inspection.
Ohio EPA Division of Materials and Waste Management	November 14, 2016	RIS voluntarily disclosed an instance of noncompliance. To resolve the violation and prevent reoccurrence RIS has implemented additional procedural checks and balances to ensure compatibility guidelines are followed at all times. RIS received a letter indicating its Return to Compliance dated January 17, 2017.
U.S. EPA, NEIC	September 26 through September 30, 2016	U.S. EPA conducted a waste-focused inspection of the facility. On February 27, 2018, RIS received a letter from U.S. EPA noting SubPart CC violations related to tank monitoring, and waste repackaging. As a result, RIS responded on March 8, 2018 and May 7, 2018 documenting: the use of a revised a calibration method for monitoring equipment; replacement of tank valve identification tags; and RIS' repackaging processes. On July 8, 2020, U.S. EPA issued a response stating that RIS' operational unit used during waste repackaging (barge) constituted waste storage without a permit. RIS disagreed with the allegation as the barge is only used to repack waste and does not function as a tank or a storage unit. On August 23, 2021, RIS and U.S. EPA entered into a Consent Agreement and Final Order ("CAFO") regarding the use of the barge at RIS. Under the agreement RIS will continue use of the barge to repack bulk wastes. RIS also agreed to pay a fine of \$20,015. In addition, RIS agreed to add a description of the operations conducted within the barge into its State and Federal RCRA Permits.
Ohio EPA Division of Materials and Waste Management	September 19 – 21, 2016	Semi-Annual CEI. No violations noted.

Curtis Bay

VIOLATIONS/FINES/CONSENT ORDERS

List and describe all notices of violation in the last (3) three years: Air

Since 2016, the plant has received the following:

2016. 3 NOV's for Opacity, HCL and CO.

2017. There was one NOV for CO.

2018. The plant failed a stack test for Mercury which resulted in an NOV.

In late 2015 the Owners of Curtis Bay Energy realized that the leadership team did not meet the standard they had set for the facility. A new leadership plan was put in place and by the end of June 2016, a completely new leadership team was formed including the CEO, CFO, Director of Operations, Compliance Manager, Safety Manager, and Maintenance Manager. The new

5/10/2022

Customer audit questionnaire

15

Confidential

members of the management team are experts and highly regarded in their fields. Over the next 6-12months the plant was brought back into full regulatory compliance. There have only been a few exceedances since the management transition.

Safety Compliance

LAST OSHA INSPECTION

When was the most recent federal/local labor safety inspection (e.g., OSHA or MSHA in the US)?

Causes and amounts A disgruntled employee called OSHA regarding some work issues. OSHA performed an inspection and cited the facility for inappropriate means of tipping sharps containers, location/placement of the eye wash stations, and other items. All items were abated, and the facility was issued a fine for \$21,725 although the facility was able to negotiate and lower the fine to \$9,760.

Causes and amounts: OSHA citation (\$9,760). There have been no OSHA inspections since that time

SELF INSPECTIONS

Frequency of inspections for waste, wastewater, air, and other:

- Solid Waste: Quarterly
- Air: Stack tests once annually per incinerator
- POTW: none conducted
- Stormwater: infrequent

FIRES/EXPLOSIONS

There have been no fires or explosions at the site in the last five years.

FATALITIES

There have been no fatalities at the site in the last five years.

INJURY AND ILLNESS (300 LOGS- 3 YEAR)

- Injuries and illnesses:
 - Under the regulatory framework applicable to this facility's location, the facility is required to document injuries/illnesses.
 - Under the regulatory framework applicable to this facility's location, the facility is required to routinely report their documented injuries/illnesses.
- Employees names will not be included in any documentation provided (redact details as necessary). If provided the documentation is included in the attachment:
 - Facility reviewer may request copies of non-confidential documentation and reports filed (where required) concerning injuries/illness reporting. Employees

XIX. Appendix F: Compliance Matrix

Citation	Summary of Applicable Requirements	Plan Sections
4.116.040(a)	Contact Information	II
4.116.040(b)	Collection System Description	III
4.116.040(c)	Handling & Disposal System Description	IV
4.116.040(d)	Policies & Procedures Description	V
4.116.040(e)	Patient Privacy	III.D
4.116.040(f)	Public Education Effort & Promotion Description	VI
4.116.040(g)	Short-term & Long-term Goals	VIII
4.116.040(h)	Additional Plan Considerations	IX
4.116.050(b)(1)	Reasonable Convenient & Equitable Access	III.A
4.116.050(b)(2)	Safe & Secure Systems	III.D
4.116.050(b)(3)	Drop-Off Site Preference	III.F
4.116.050(b)(4)	Collector/Drop-Off Site Inclusion	III.F
4.116.050(b)(5)	Mail-Back Services	III.C
4.116.050(c)	Drop-Off Sites at County-Owned Pharmacy	III.F
4.116.050(d)	Drop-Off Site Hours & Bins	III.F
4.116.060(a)(1)	Promotion	VII.A
4.116.060(a)(2)	Clear Standardized Instructions	VII.B
4.116.060(a)(3)	Toll-Free Number & Website	VII.C
4.116.060(a)(4)	Biennial Survey	VII.F
4.116.060(b)	Language Translation Requirements	VII.G
4.116.060(c)	Single System of Promotion	VII.H & VII
4.116.070(a)	Hazardous Waste Disposal	IV
4.116.070(b)	Petition for Alternate Disposal	IV
4.116.070(c)	Final Disposal Technologies	IV
4.116.090(a)(1)	Participating Producer List	XI
4.116.090(a)(2)	Amount, by Weight, of Collected Covered Drugs	XI
4.116.090(a)(3)	Drop-Off Site List	XI
4.116.090(a)(4)	Number of Mailers Provided for Disabled and/or Home-Bound County Residents	XI
4.116.090(a)(5)	Locations Mailers Provided	XI

4.116.090(a)(6)	Collection Events Dates & Locations	XI
4.116.050(a)(7)	Transporters and Disposal Facilities	XI
4.116.090(a)(8)	Safety & Security	XI
4.116.090(a)(9)	Public Education, Outreach & Evaluation Activities	XI
4.116.090(a)(10)	Recycling	XI
4.116.090(a)(11)	Goals	XI
4.116.090(a)(12)	Expenditures	XI
4.116.090(b)	Report Availability	XI
4.116.090(c)	Reporting Period	XI